

PUBLIC UTILITIES COMMISSION

505 VAN NESS AVENUE

SAN FRANCISCO, CA 94102-3298



**Advice Letter 4202-E**

August 22, 2013

Brian K. Cherry  
Vice President, Regulatory Relations  
Pacific Gas and Electric Company  
77 Beale Street, Mail Code B10C  
P.O. Box 770000  
San Francisco, CA 94177

**SUBJECT: City of Lemoore Masonry Block Wall Encroachment Agreement - Request for Approval Under Section 851**

Dear Mr. Cherry:

Advice Letter 4202-E is effective as of August 15, 2013.

Sincerely,

A handwritten signature in cursive script that reads "Edward F. Randolph".

Edward F. Randolph, Director  
Energy Division

March 14, 2013

**Advice 4202-E**  
(Pacific Gas and Electric Company ID U 39 E)

Public Utilities Commission of the State of California

**Subject: City of Lemoore Masonry Block Wall Encroachment Agreement - Request for Approval Under Section 851**

**Purpose**

Pacific Gas and Electric Company (“PG&E”) requests approval under Public Utilities Code Section 851 to enter into an Encroachment Agreement (“Agreement”) with the city of Lemoore (“City”) permitting the City to construct certain decorative masonry block walls (“Block Wall”) and thereby encroach within PG&E’s electric transmission easement (the “Easement”) and right-of-way.

**Background**

On April 3, 2007, PG&E submitted Advice 3028-E (“Lennar Masonry Block Wall Encroachment Agreement - Request for Approval Under Section 851”) seeking authorization for PG&E to enter into an encroachment agreement with Lennar Fresno Corporation (“Lennar”) for the construction of a masonry block wall around a new subdivision development (“Subdivision”). The encroachment agreement with Lennar was necessary because the block wall would encroach on PG&E’s Easement for the transmission of electric energy supporting the Henrietta-Lemoore 70 kV electric transmission wood pole line. The advice letter was approved by Resolution E-4099 on February 14, 2008.

Last year, the City approached PG&E about constructing a second portion of the Block Wall for the Subdivision (“Project Area”) that would also encroach on PG&E’s Easement.<sup>1</sup> Specifically, the City is requesting from PG&E an Agreement to construct a second portion of decorative masonry block walls including concrete foundations and other associated improvements (the “Improvements”) within PG&E’s Easement, the construction of which violates the prohibition against buildings or other structures contained in the Easement. The construction of a 7-foot high Block Wall around the exterior of the entire subdivision is a requirement under the City’s Zoning Ordinance along all arterial and collector streets.

---

<sup>1</sup> The City maintains the original portion of the Block Wall installed by Lennar.

The City and PG&E will enter into the Agreement, contingent on California Public Utilities Commission (“CPUC” or “Commission”) approval, whereby PG&E will grant permission for the construction of the Block Wall within the Easement. PG&E has determined that the Improvements do not interfere with the present full use of the Easement by PG&E, and PG&E is therefore willing to agree to allow such encroachment within the Easement subject to the terms of the Agreement, more specifically described in **Attachment 1**.

**(a) Identity and Addresses of All Parties to the Proposed Transaction:**

Pacific Gas and Electric Company	City of Lemoore, Public Works Dept.
Ann H. Kim	David R. Wlaschin, Director
Law Department	711 W. Cinnamon Drive
P.O. Box 7442	Lemoore, California 93245
San Francisco, CA 94120	Telephone: (559) 924-6735
Telephone: (415) 973-7467	E-mail: dwlaschin@lemoore.com
Facsimile: (415) 973-5520	
Email: AHK4@pge.com	

**(b) Complete Description of the Property Including Present Location, Condition and Use:**

PG&E owns, operates and maintains the Henrietta-Lemoore 70 kV overhead electric transmission wood-pole line, a portion of which crosses a parcel of land owned by the City, located on the north side of Fallen Leaf Drive between 19<sup>th</sup> Avenue and Liberty Avenue in the city of Lemoore, King County, California and identified as Assessors Parcel Number (“APN”) 021-790-063, more specifically described in Exhibit A, Attachment 1.

PG&E is the owner of the Easement for the transmission of electric energy and for all purposes connected therewith, as set forth in the initial Grant of Easements (1) dated September 6, 1952, and recorded in Book 537 of Official Records at page 111, and (2) dated April 9, 1962 and recorded in Book 808 of Official Records at Page 340, Kings County Records, which provide in part that “no building or like structure shall be erected or constructed on the premises,” more specifically described in the Grant of Easements attached hereto as **Attachment 2**.

The area surrounding the Property located adjacent to the east side of the Easement has been developed into a single-family residential subdivision by Lennar. As a condition of the development approval, Lennar was responsible to install a permanent 7-foot-high concrete masonry block wall which includes retaining walls, concrete foundations and other associated improvements as a decorative barrier between the subdivision boundary of the proposed housing development and nearby public roads. The only feasible location for the

masonry block wall had been determined by Lennar to be within PG&E's Easement. The city of Lemoore Public Works Departments, which oversaw the project and maintains the masonry stone block wall is requesting for an additional area of encroachment to build a second portion of the masonry block wall.

**(c) Intended Use of the Property:**

The proposed encroachment onto PG&E's Easement is for the construction and installation of the Improvements. The City is requesting permission from PG&E in the form of the Agreement to allow the construction of the Block Wall that will run parallel with and inside of the Easement. The Agreement will require that the City maintain the Block Wall for the term of the Agreement, unless PG&E exercises an express unilateral right to terminate the Agreement on 90 days advance notice in the event the sound wall ever interferes with PG&E's operations in the Easement, as more particularly described in the Agreement. The Block Wall, as currently proposed, will not interfere with PG&E's existing facilities and will be designed and constructed in such a way so as not to hinder access to, or maintenance of, PG&E's facilities in the Easement. The project design calls for adequate access on both sides of the sound wall so that PG&E maintenance can be performed without hindrance. Maps of the construction area are provided in Exhibit C to Attachment 1.

**(d) Complete Description of Financial Terms of the Proposed Transaction:**

PG&E is not collecting any use fees associated with granting the Encroachment Agreement to the City. Placement of the Block Wall within the Easement does not rise to the level of a right that has any realizable economic value to PG&E.

**(e) Description of How Financial Proceeds of the Transaction Will Be Distributed:**

Not applicable.

**(f) Statement on the Impact of the Transaction on Ratebase and Any Effect on the Ability of the Utility to Serve Customers and the Public:**

The transaction will not impact PG&E's ability to provide safe and reliable service to its customers and public at-large.

**(g) The Original Cost, Present Book Value, and Present Fair Market Value for Sales of Real Property and Depreciable Assets, and a Detailed Description of How the Fair Market Value Was Determined (e.g., Appraisal):**

Not Applicable.

**(h) The Fair Market Rental Value for Leases of Real Property, and a Detailed Description of How the Fair Market Rental Value Was Determined:**

Not Applicable.

**(i) For Fair Market Rental Value of the Easement or Right-of-Way and a Detailed Description of How the Fair Market Rental Value Was Determined:**

Not Applicable.

**(j) A Complete Description of any Recent Past (Within the Prior Two Years) or Anticipated Future Transactions that May Appear To Be Related to the Present Transaction<sup>2</sup>:**

Not Applicable

**(k) Sufficient Information and Documentation (Including Environmental Review Information) to Indicate that All Criteria Set Forth in Rule 3 of General Order (“GO”) 173 are Satisfied:**

PG&E has provided information in this Advice Letter to satisfy the eligibility criteria under GO 173 in that:

- The activity proposed in the transaction will not require environmental review by the CPUC as a Lead Agency;
- The transaction will not have an adverse effect on the public interest or on the ability of PG&E to provide safe and reliable service to its customers at reasonable rates;
- The transaction will not materially impact the rate base of PG&E; and
- The transaction does not warrant a more comprehensive review that would be provided through a formal Section 851 application.

**(l) Additional Information to Assist in the Review of the Advice Letter:**

No information is readily available other than what has already been included within this advice letter filing.

---

<sup>2</sup> During adoption of the Advice Letter pilot program in ALJ-186 (later followed by ALJ-202 and ALJ-244), this category of information was included to enable the CPUC to ensure that utilities were not seeking to circumvent the \$5 million Advice Letter threshold by dividing what is a single asset with a value of more than \$5 million into component parts each valued at less than \$5 million, which is clearly not the case here. (See CPUC Resolution ALJ-186, issued August 25, 2005, mimeo, p.5.)

**(m) Environmental Information**

Pursuant to GO 173, the Advice Letter program applies to proposed transactions that will not require environmental review by the CPUC as a lead agency under the California Environmental Quality Act ("CEQA") either because: (a) a statutory or categorical exemption applies (the applicant must provide a notice of exemption from the Lead Agency or explain by an exemption applies), or (b) because the transaction is not a project under CEQA (the applicant must explain the reasons why it believes that the transaction is not a project), or (c) because another public agency, acting as the Lead Agency under CEQA, has completed environmental review of the project, and the Commission is required to perform environmental review of the project only as a Responsible Agency under CEQA.

**(1) Exemption**

a. Has the proposed transaction been found exempt from CEQA by a government agency?

i. If yes, please attach notice of exemption. Please provide name of agency, date of Notice of Exemption, and State Clearinghouse number.

Not Applicable

ii. If no, does the applicant contend that the project is exempt from CEQA? If yes, please identify the specific CEQA exemption or exemptions that apply to the transaction, citing to the applicable State CEQA Guideline(s) and/or Statute(s).

Not Applicable

**(2) Not a "Project" Under CEQA**

If the transaction is not a "project" under CEQA, please explain why.

Not Applicable

**(3) CPUC as a Responsible Agency under CEQA**

If another public agency, acting as the Lead Agency under CEQA, has completed an environmental review of the project and has approved the final CEQA documents, and the Commission is a Responsible Agency under CEQA, the applicant shall provide the following.

- a. The name, address, and phone number of the Lead Agency, the type of CEQA document that was prepared (Environmental Impact Report, Negative Declaration, Mitigated Negative Declaration), the date on which the Lead Agency approved the CEQA document, the date on which a Notice of Determination was filed.

<b>Lead Agency Information</b>	<b>Lead Agency:</b> City of Lemoore <b>Address:</b> 119 Fox Street Lemoore, CA 93245 <b>Phone Number:</b> (559) 924-6740
<b>CEQA Document</b>	Mitigated Negative Declaration (“MND”)
<b>Date Approved by Lead Agency</b>	December 27, 2004
<b>Date Notice of Determination Filed</b>	February 16, 2005

- b. A copy of all CEQA documents prepared by or for the Lead Agency regarding the project and the Lead Agency’s resolution or other document approving the CEQA documents.

Copies of the Final Mitigated Negative Declaration (“MND”) and the City’s Council issued Resolution 2005-08, which adopted the City’s 2004 CEQA review and amended the City’s Zoning Ordinance for the Project Area are provided in **Attachments 3 and 4**, respectively. A copy of the Notice of Determination adopting the MND and the amendment to the City’s Zoning Ordinance for the Project Area is provided in **Attachment 5**.

- c. A list of section and page numbers for the environmental impacts, mitigation measures, and findings in the prior CEQA documents that relate to the approval sought from the Commission.

Environmental Impacts	Final MND ( <b>Attachment 3</b> ) Pages 11-12
Mitigation Measures	Final MND ( <b>Attachment 3</b> ) Pages 11-12
Findings	Final MND ( <b>Attachment 3</b> ) Pages 1,3

- d. An explanation of any aspect of the project or its environmental setting which has changed since the issuance of the prior CEQA document.

PG&E is not aware of any changes that have occurred since the issuance of the MND and Initial Study.

- e. A statement of whether the project will require approval by additional public agencies other than the Commission and the Lead Agency, and, if so, the name and address of each agency and the type of approval required.

The project will not require approval by additional public agencies other than the Commission and the Lead Agency.

### **Protests**

Anyone wishing to protest this filing may do so by sending a letter by **April 3, 2013**, which is 20 days from the date of this filing. The protest must state the grounds upon which it is based, including such items as financial and service impact, and should be submitted expeditiously. Protests should be mailed to:

CPUC Energy Division  
ED Tariff Unit  
505 Van Ness Avenue, 4<sup>th</sup> Floor  
San Francisco, California 94102

Facsimile: (415) 703-2200  
E-mail: EDTariffUnit@cpuc.ca.gov

Copies of protests also should be mailed to the attention of the Director, Energy Division, Room 4004, at the address shown above.

The protest shall also be sent to PG&E either via E-mail or U.S. mail (and by facsimile, if possible) at the address shown below on the same date it is mailed or delivered to the Commission:

Brian K. Cherry  
Vice President, Regulatory Relations  
Pacific Gas and Electric Company  
77 Beale Street, Mail Code B10C  
P.O. Box 770000  
San Francisco, California 94177

Facsimile: (415) 973-7226  
E-mail: PGETariffs@pge.com



Any person (including individuals, groups, or organizations) may protest or respond to an advice letter. (General Order 96-B, Section 7.4.) The protest shall contain the following information: specification of the advice letter protested; grounds for the protest; supporting factual information or legal argument; name, telephone number, postal address, and (where appropriate) e-mail address of the protestant; and statement that the protest was sent to the utility no later than the day on which the protest was submitted to the reviewing Industry Division (General Order 96-B, Section 3.11).

### **Effective Date**

Pursuant to the review process outlined in General Order 173, PG&E requests that this **Tier 3** advice filing become effective as soon as possible.

### **Notice**

In accordance with General Order 96-B, Section IV, a copy of this advice letter is being sent electronically and/or via U.S. mail to parties shown on the attached list. Address changes to the General Order 96-B service list should be directed to PG&E at email address PGETariffs@pge.com. For changes to any other service list, please contact the Commission's Process Office at (415) 703-2021 or at Process\_Office@cpuc.ca.gov. Send all electronic approvals to PGETariffs@pge.com. Advice letter filings can also be accessed electronically at: <http://www.pge.com/tariffs>.



Vice President – Regulatory Relations

### **Attachments**

Attachment 1 – Encroachment Agreement

Attachment 2 – Original Easement

Attachment 3 – Final Mitigated Negative Declaration

Attachment 4 – City's Council Issued Resolution 2005-08

Attachment 5 – Notice of Determination for the Mitigated Negative Declaration

\*\*\*\*\* SERVICE LIST Advice 4202-E \*\*\*\*\*  
APPENDIX A

Karen Clopton  
Administrative Law Judge Division  
505 Van Ness Avenue  
San Francisco, CA 94102  
(415) 703-2008  
kvc@cpuc.ca.gov

Myra J. Prestidge  
Administrative Law Judge Division  
505 Van Ness Avenue  
San Francisco, CA 94102  
(415) 703-2629  
tom@cpuc.ca.gov

Jonathan Reiger  
Legal Division  
505 Van Ness Avenue  
San Francisco, CA 94102  
(415) 355-5596  
jzr@cpuc.ca.gov

Mary Jo Borak  
Energy Division  
505 Van Ness Avenue  
San Francisco, CA 94102  
(415) 703-1333  
bor@cpuc.ca.gov

Edward Randolph  
Energy Division  
505 Van Ness Avenue  
San Francisco, CA 94102  
(415) 703-2083  
efr@cpuc.ca.gov

Brewster Fong  
Division of Ratepayer Advocates  
505 Van Ness Avenue  
San Francisco, CA 94102  
(415) 703- 2187  
bfs@cpuc.ca.gov

Andrew Barnsdale  
Energy Division  
505 Van Ness Avenue  
San Francisco, CA 94102  
(415) 703-3221  
bca@cpuc.ca.gov

\*\*\*\*\* AGENCIES \*\*\*\*\*

City of Lemoore, Public Works Dept.  
David R. Wlaschin, Director  
711 W. Cinnamon Drive  
Lemoore, CA 93245  
Telephone: (559) 924-6735  
E-mail: dwlaschin@lemoore.com

# CALIFORNIA PUBLIC UTILITIES COMMISSION

## ADVICE LETTER FILING SUMMARY ENERGY UTILITY

MUST BE COMPLETED BY UTILITY (Attach additional pages as needed)

Company name/CPUC Utility No. **Pacific Gas and Electric Company (ID U39 E)**

Utility type:

ELC       GAS  
 PLC       HEAT       WATER

Contact Person: Igor Grinberg

Phone #: (415) 973-8580

E-mail: ixg8@pge.com and PGETariffs@pge.com

### EXPLANATION OF UTILITY TYPE

ELC = Electric      GAS = Gas  
PLC = Pipeline      HEAT = Heat      WATER = Water

(Date Filed/ Received Stamp by CPUC)

Advice Letter (AL) #: **4202-E**

Tier: **3**

Subject of AL: **City of Lemoore Masonry Block Wall Encroachment Agreement - Request for Approval Under Section 851**

Keywords (choose from CPUC listing): Agreements, Contracts

AL filing type:  Monthly  Quarterly  Annual  One-Time  Other \_\_\_\_\_

If AL filed in compliance with a Commission order, indicate relevant Decision/Resolution #:

Does AL replace a withdrawn or rejected AL? If so, identify the prior AL: No

Summarize differences between the AL and the prior withdrawn or rejected AL: \_\_\_\_\_

Is AL requesting confidential treatment? If so, what information is the utility seeking confidential treatment for: No

Confidential information will be made available to those who have executed a nondisclosure agreement: N/A

Name(s) and contact information of the person(s) who will provide the nondisclosure agreement and access to the confidential information: \_\_\_\_\_

Resolution Required?  Yes  No

Requested effective date: **Upon Approval**

No. of tariff sheets: N/A

Estimated system annual revenue effect (%): N/A

Estimated system average rate effect (%): N/A

When rates are affected by AL, include attachment in AL showing average rate effects on customer classes (residential, small commercial, large C/I, agricultural, lighting).

Tariff schedules affected: N/A

Service affected and changes proposed: N/A

Pending advice letters that revise the same tariff sheets: N/A

Protests, dispositions, and all other correspondence regarding this AL are due no later than 20 days after the date of this filing, unless otherwise authorized by the Commission, and shall be sent to:

**CPUC, Energy Division**  
**ED Tariff Unit**  
**505 Van Ness Avenue, 4th Floor**  
**San Francisco, CA 94102**  
**E-mail: [EDTariffUnit@cpuc.ca.gov](mailto:EDTariffUnit@cpuc.ca.gov)**

**Pacific Gas and Electric Company**  
**Attn: Brian Cherry**  
**Vice President, Regulatory Relations**  
**77 Beale Street, Mail Code B10C**  
**P.O. Box 770000**  
**San Francisco, CA 94177**  
**E-mail: [PGETariffs@pge.com](mailto:PGETariffs@pge.com)**

Advice 4202-E  
March 14, 2013

Attachment 1:  
Encroachment Agreement

RECORDING REQUESTED BY AND RETURN TO:

PACIFIC GAS AND ELECTRIC COMPANY

Land Services Office

650 O Street Mail Bag 23

Fresno, CA 93760-0001

Location: City/Uninc \_\_\_\_\_

Recording Fee \$ \_\_\_\_\_

Document Transfer Tax \$ \_\_\_\_\_

This is a conveyance where the consideration and Value is less than \$100.00 (R&T 11911).

Computed on Full Value of Property Conveyed, or

Computed on Full Value Less Liens & Encumbrances Remaining at Time of Sale

\_\_\_\_\_  
Signature of declarant or agent determining tax

LD 2219-20-

(APN 021-790-063)

## ENCROACHMENT AGREEMENT

This Encroachment Agreement (this "**Agreement**") is made and entered into this \_\_\_ day of \_\_\_\_\_, 2012 by PACIFIC GAS AND ELECTRIC COMPANY, a California corporation, hereinafter called "**PG&E**", and CITY OF LEMOORE, a public body of the state of California, hereinafter called "**Owner**."

### RECITALS

A. Owner is the fee title owner of certain real property within Kings County, State of California, Assessor's Parcel Number APN 021-790-063 (hereinafter, the "**Property**") legally described in **Exhibit "A"** attached hereto and made a part hereof.

B. PG&E is the owner of a certain easement and right-of-way (the "**Easement**") for the transmission of electric energy and for all other purposes connected therewith, as set forth in the Grant of Easements (1) dated September 6, 1952, and recorded in Book 537 of Official Records at page 111, and (2) dated April 9, 1962 and recorded in Book 808 of Official Records at Page 340, Kings County Records which provides in part that "no building or like structure shall be erected or constructed on the premises." The portion of the Property encumbered by the Easement is hereinafter referred to as the "**Easement Area**."

C. Owner proposes to construct concrete block sound walls including concrete foundations and other improvements associated therewith (the "**Improvements**") on the Easement

Area, the construction of which violates the prohibition against buildings or other structures contained in the Easement. The Easement Area and the portion of the Easement Area subject to such encroachment (the “**Encroachment Area**”) are legally described in **Exhibit “B”** attached hereto and made a part hereof, and are shown on the map attached as **Exhibit “C”**.

D. Owner has requested that PG&E grant permission for the construction of the Improvements within the Easement Area. PG&E has determined that the Improvements, to be constructed pursuant to plans and specifications approved by PG&E, do not interfere with the present full use of the Easement Area by PG&E, and PG&E is therefore willing to agree to allow such encroachment on the Easement Area on the terms and subject to the conditions set forth herein.

NOW, THEREFORE, in consideration of the foregoing and for other good and valuable consideration, the receipt and sufficiency of which are hereby acknowledged, Owner and PG&E hereby agree as follows:

1. Consent to Encroachment. Notwithstanding the prohibition in the Easement, PG&E hereby consents to the encroachment of the **Improvements** onto the Easement Area by various distances, in the manner and location as more specifically set forth in **Exhibit “B” and “C”** subject to the terms and conditions set forth herein. In addition, Owner shall have the right of ingress and egress over the Easement Area to obtain access to the Encroachment Area and the Improvements when necessary to fulfill Owner's obligations under this Agreement, in such areas as PG&E determines, in its sole and absolute discretion, will occasion the least practicable damage and inconvenience to PG&E, its facilities and operations.

2. Governmental Approvals. This Agreement shall not become effective, notwithstanding that it may have been executed and delivered by the parties, and Owner shall not commence any activity hereunder, unless and until the California Public Utilities Commission (the “**CPUC**”) approves this Agreement by an order which is final, unconditional and unappealable (including exhaustion of all administrative appeals or remedies before the CPUC), and the terms and conditions of such CPUC approval are satisfactory to PG&E in its sole and absolute discretion. This Agreement is made subject to all the provisions of such approval, as more particularly set forth in CPUC Decision \_\_\_\_\_ (Application No. \_\_\_\_\_), in like manner as though said provisions were set forth in full herein.

3. Termination; Restoration. **PG&E may terminate Owner's rights under this Agreement, at any time, upon ninety (90) days written notice to the Owner, if PG&E, in its sole and absolute discretion, should determine that Owner's use of the Easement Area is inconsistent with PG&E's operational needs in the future, or in any way interferes with, impairs or otherwise impedes PG&E's full use of facilities installed or that may be installed by PG&E in the vicinity of the Easement Area. Upon such termination, Owner, at Owner's sole cost and expense, shall remove all Improvements that encroach upon the Easement Area and shall repair and restore the Easement Area as nearly as possible to the condition that existed prior to the construction of said Improvements. Owner shall pay the entire cost of such removal and restoration, and PG&E shall have no liability for any costs caused by or related to any such termination. If Owner fails to remove all Improvements that encroach onto the Easement Area or fail to repair or restore the Property within said ninety (90) day**

period, PG&E may perform such removal, repair or restoration as necessary and recover such costs and expenses therefore from Owner. Owner agrees to allow access to PG&E onto the Property for such purpose, and Owner shall pay all such costs and expenses within ten (10) days of receipt of an invoice therefore. Owner further acknowledge that PG&E's termination right shall not be affected by any Improvements that Owner has made to the Easement Area, regardless of the nature or extent of those Improvements. Owner understands and agrees that notwithstanding that Owner may have made a substantial investment in such improvements, Owner shall not be entitled to any compensation whatsoever for the termination of Owner's rights under this Agreement by PG&E. (Owner to initial here \_\_\_\_\_, \_\_\_\_\_).

4. Indemnification; Release.

(a) Indemnification. Owner shall, to the maximum extent permitted by law, indemnify, protect, defend and hold harmless PG&E, its parent corporation, subsidiaries and affiliates, and their respective officers, managers, directors, representatives, agents, employees, transferees, successors and assigns (each, an "**Indemnitee**" and collectively, "**Indemnitees**") from and against all claims, losses (including, but not limited to, diminution in value), actions, demands, damages, costs, expenses (including, but not limited to, experts fees and reasonable attorneys' fees and costs) and liabilities of whatever kind or nature (collectively, "**Claims**"), which arise from or are in any way connected with the occupancy or use of the Easement Area by Owner or Owner' contractors, agents, or invitees, or the exercise by Owner of its rights hereunder, or the performance of, or failure to perform, Owner's duties under this Agreement, including, but not limited to, Claims arising out of: (1) injury to or death of persons, including but not limited to employees of PG&E; (2) injury to property or other interest of PG&E, Owner or any third party; (3) violation of any applicable federal, state, or local laws, statutes, regulations, or ordinances, including all legal requirements relating to human health or the environment, and including any liability which may be imposed by law or regulation without regard to fault; excepting only with respect to any Indemnitee, any Claim arising from the sole, active negligence or willful misconduct of such Indemnitee. In the event any action or proceeding is brought against any Indemnitee for any Claim against which Owner are obligated to indemnify or provide a defense hereunder, Owner upon written notice from PG&E shall defend such action or proceeding at Owner' sole expense by counsel approved by PG&E, which approval shall not be unreasonably withheld, conditioned or delayed.

(b) Release. Owner accepts all risk relating to its occupancy and use of the Easement Area. PG&E shall not be liable to Owner for, and Owner hereby waives, releases, exonerates, discharges and covenants not to sue PG&E and the other Indemnitees from, any and all liability, whether in contract, tort or on any other basis, for any injury, damage, or loss resulting from or attributable to any occurrence on or about the Easement Area, the condition of Easement Area, the use or occupancy of the Easement Area by Owner, or PG&E's operation and maintenance of PG&E's facilities in the vicinity of the Easement Area, except in the case of any Indemnitee, any injury, damage, or loss arising from the sole, active negligence or willful misconduct of such Indemnitee.

5. Compliance with Laws. Owner shall, at its sole cost and expense, promptly comply with all laws, statutes, ordinances, rules, regulations, requirements or orders of municipal, state, and federal authorities now in force or that may later be in force, with the conditions of any permit, relating to Owner's use or occupancy of the Easement Area.

6. Alterations. Except for the Improvements authorized to be constructed pursuant to this Agreement, Owner shall not construct any additional buildings or structures on the Easement Area, nor shall Owner make any alteration, addition or improvement to the Easement Area that would increase the Encroachment Area, either horizontally or vertically. Owner shall not drill, bore or excavate on the Easement Area except in connection with construction of the Improvements pursuant to plans and specifications approved by PG&E, or a removal of the Improvements as required by this Agreement.

7. Damage or Destruction. In the event that the Improvements which encroach onto the Easement Area shall be destroyed or demolished, Owner shall not rebuild the Improvements on any part of the Easement Area except pursuant to plans and specifications approved by PG&E.

8. Condition of Easement Area. Owner accepts the Encroachment Area and the Easement Area in its existing physical condition, without warranty by PG&E or any duty or obligation on the part of PG&E to maintain the Easement Area. Owner understands that numerous hazards, environmental or otherwise, may be located in, on, or underlying the Easement Area, and that hazardous materials may be used in connection with PG&E facilities that may be operated in the Easement Area, and agrees that entry onto the Easement Area is at Owner's sole risk and expense

9. Maintenance. Owner shall be responsible for the maintenance of the Improvements in good condition and repair, and Owner shall coordinate all activities regarding the maintenance of the Improvements to reasonably minimize any interference with the use by PG&E of the Easement Area, and Owner shall conduct its activities in such a manner so as not to endanger the Easement, the environment and human health and safety. Owner shall be responsible for remediation of any hazardous materials release caused by Owner, and to clean and remove debris and/or promptly repair any damages to the Easement Area following any entry or activity by Owner, returning the Easement Area to a like or better condition.

10. Reserved Rights. PG&E reserves the right to use the Easement Area for such purposes as it may deem necessary or appropriate if, and whenever, in the interest of its service to its patrons or consumers or the public, it shall appear necessary or desirable to do so. Furthermore, PG&E reserves the right to restrict access to the Easement Area if emergency repairs or maintenance are required to PG&E facilities in the vicinity of the Easement Area.

11. Insurance. Prior to the Effective Date of this Agreement, Owner shall procure, and thereafter Owner shall carry and maintain in effect at all times the following insurance: Worker's Compensation in compliance with applicable labor codes, acts, laws or statutes, state or federal, where Owner perform work and Employer's Liability insurance with limits not be less than \$1,000,000 for injury or death, each accident; Commercial General Liability for bodily injury and property damage with limits of not less than \$1,000,000 each occurrence/\$2,000,000 aggregate; Business Auto, code 1 "any auto" combined single limit no less than \$1,000,000 each accident.



Owner is also responsible for causing its agents, contractors and subcontractors to comply with the insurance requirements of this Agreement at all relevant times.

12. Notice. Any notices or communications hereunder shall be in writing and shall be personally delivered or sent by first class mail, certified or registered, postage prepaid, or sent by national overnight courier, with charges prepaid for next business day delivery, addressed to the addressee party at its address or addresses listed below, or to such other address or addresses for a party as such party may from time to time designate by notice given to the other party. Notices shall be deemed received, if sent by personal delivery upon actual receipt by the party being sent the notice, or on the expiration of three (3) business days after the date of mailing, or on the following business day if sent by overnight courier

If to PG&E:

Pacific Gas and Electric Company  
Attention: Land Agent  
650 O Street Mail Bag 23  
Fresno, CA 93760

With a copy to:

(By Mail)  
Wendy T. Coleman, Esq.  
Pacific Gas and Electric Company  
P.O. Box 7442  
San Francisco, CA 94120

**OR**

(By Courier)  
Wendy T. Coleman, Esq.  
Pacific Gas and Electric Company  
77 Beale Street, Mail Code B30A  
San Francisco, CA 94105

If to Owner:

City of Lemoore  
Director of Public Works  
Attention: David Wlaschin  
711 W. Cinnamon Drive  
Lemoore, CA 93245

13. Governing Law. This Agreement shall in all respects be interpreted, enforced, and governed by and under the laws of the State of California.

14. Entire Agreement. This Agreement and the Deed, supersedes all previous oral and written agreements between and representations by or on behalf of the parties and constitutes the

entire agreement of the parties with respect to the subject matter hereof. This Agreement may not be amended except by a written agreement executed by the parties.

15. Binding Effect. This Agreement and the covenants and agreements contained herein shall be binding upon, and shall inure to the benefit of, the parties hereto and their respective heirs, successors and assigns (subject to the provisions of Section 17 below). No assignment or delegation by Owner, whether by operation of law or otherwise, shall relieve Owner of any of its duties, obligations or liabilities hereunder, in whole or in part. The covenants of Owner hereunder shall run with the land.

16. Assignment. This Agreement and the rights of Owner hereunder are appurtenant to the Property presently owned by Owner and may not be separately assigned, transferred, conveyed or encumbered. Any purported assignment, transfer, conveyance or encumbrance violating the foregoing condition shall be void and of no effect.

17. Attorneys' Fees. Should either party bring an action against the other party, by reason of or alleging the failure of the other party with respect to any or all of its obligations hereunder, whether for declaratory or other relief, then the party which prevails in such action shall be entitled to its reasonable attorneys' fees (of both in-house and outside counsel) and expenses related to such action, in addition to all other recovery or relief. A party shall be deemed to have prevailed in any such action (without limiting the generality of the foregoing) if such action is dismissed upon the payment by the other party of the sums allegedly due or the performance of obligations allegedly not complied with, or if such party obtains substantially the relief sought by it in the action, irrespective of whether such action is prosecuted to judgment.

18. Survival of Obligations. Owner's obligations under Sections 3 and 4 of this Agreement, and all representations, warranties, indemnities or other provisions which by their nature survive termination shall survive the exercise of PG&E's termination rights pursuant to Section 3 of this Agreement.

19. No Waiver. No waiver with respect to any provision of this Agreement shall be effective unless in writing and signed by the party against whom it is asserted. No waiver of any provision of this Agreement by a party shall be construed as a waiver of any subsequent breach or failure of the same term or condition, or as a waiver of any other provision of this Agreement.

20. Captions. The captions in this Agreement are for reference only and shall in no way define or interpret any provision hereof.

21. Counterparts. This Agreement may be executed in identical counterpart copies, each of which shall be an original, but all of which taken together shall constitute one and the same agreement.

22. Recording. Owner hereby consents and agrees to the recording by PG&E of this Agreement against the Property. Owner agrees to sign any additional documents reasonably required to complete such recording.

23. Ratification of Deed. Except as modified by this Agreement in regard to the Property, all of the terms, conditions and provisions of the Deed shall remain in full force and effect and are hereby ratified and confirmed. To the extent the terms of the Deed are inconsistent with this Agreement, the terms of this Agreement shall control.

IN WITNESS WHEREOF, the parties have executed this Agreement as of the day and year first set forth above.

"PG&E"

"Owner"

PACIFIC GAS AND ELECTRIC COMPANY,  
a California corporation

CITY OF LEMOORE,

By: \_\_\_\_\_  
Jeff Briltz, City Manager

By: \_\_\_\_\_  
Its: Marvin Penner  
Manager, Land Management  
Land and Environmental Management

State of California

County of \_\_\_\_\_ )

On \_\_\_\_\_, before me, \_\_\_\_\_

Here insert name and title of the officer

\_\_\_\_\_,  
personally appeared \_\_\_\_\_

\_\_\_\_\_, who proved to me on the basis of satisfactory evidence to be the person(s) whose name(s) is/are subscribed to the within instrument and acknowledged to me that he/she/they executed the same in his/her/their authorized capacity(ies), and that by his/her/their signature(s) on the instrument the person(s), or the entity upon behalf of which the person(s) acted, executed the instrument.

I certify under PENALTY OF PERJURY under the laws of the State of California that the foregoing paragraph is true and correct.

WITNESS my hand and official seal.

\_\_\_\_\_  
Signature of Notary Public

(Seal)

**CAPACITY CLAIMED BY SIGNER**

- Individual(s) signing for oneself/themselves
- Corporate Officer(s) of the above named corporation(s)
- Trustee(s) of the above named Trust(s)
- Partner(s) of the above named Partnership(s)
- Attorney(s)-in-Fact of the above named Principal(s)
- Other \_\_\_\_\_

Area 4 – Fresno LSO  
Electric Transmission  
Encroachment Agreement  
MDB&M, T19S, R20E,  
SEC. 3, W ½ of NW ¼  
FERC # N/A  
Drawing # Exhibit B  
AF/RE: 2219-20-0045 & 0046  
Type of Interest 2,11b,42  
SBE# N/A  
% of Quitclaim N/A  
PM# 40541423– OP#0050  
JCN# N/A  
County Kings  
851 Approval Application No. \_\_\_\_\_ Decision \_\_\_\_\_  
Utility Notice #  
Prepared By DAV0  
Checked By KAP6

**EXHIBIT "A"**  
**Legal Description of Existing Parcels**

All of the real property situated in the City of Lemoore, County of Kings, State of California, described as follows:

Outlot A of Tract Number 821, Liberty, Phase 1, according to the map thereof recorded June 20, 2006, in Volume 21 of Licensed Surveyor's Plats, at Page 78, Kings County Records.

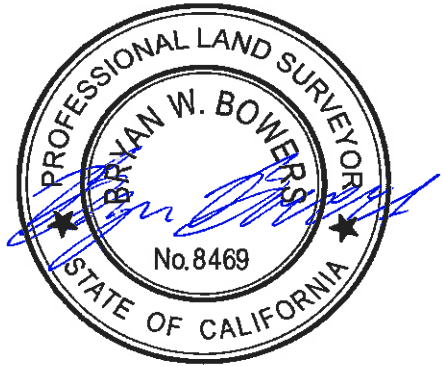

Date  
Signed 11/30/12

**EXHIBIT "B"**  
**Legal Description of PG& E Easement Encroachments**

A portion of Outlot A of Tract Number 821, "Liberty", Phase 1, according to the map thereof recorded June 20, 2006, in Volume 21 of Licensed Surveyor's Plats at Page 78, Kings County Records, situated in the City of Lemoore, County of Kings, State of California, and being more particularly described as follows:

Beginning at a point on the west line of said Outlot A, said point bears South 00°30'57" West a distance of 2.39 feet from the southwest corner of Lot 147 of said Tract Number 821; thence

- 1) South 00°30'57" West, along the west line of said Outlot A, a distance of 38.61 feet to the west-southwesterly corner of said Outlot A; thence
- 2) South 89°47'35" East, along the southerly line of said Outlot A, a distance of 63.01 feet to the southwest corner of said Outlot A; thence
- 3) South 00°33'47" West, along the westerly line of said Outlot A, a distance of 19.89 feet to the south-southwesterly corner of said Outlot A; thence
- 4) North 89°55'47" East, along the south line of said Outlot A, a distance of 139.89 feet to the intersection of said southerly line with the right-of-way of American Avenue and Jubilee Circle; thence
- 5) North 00°04'13" West, a distance of 10.00 feet to a line parallel with and 10.00 feet northerly (measured at right angles) from said south line of Outlot A; thence
- 6) South 89°55'47" West, along said parallel line, a distance of 129.78 feet to a line parallel with and 10.00 feet easterly (measured at right angles) from said westerly line of Outlot A; thence
- 7) North 00°33'47" East, along the last said parallel line, a distance of 19.84 feet to a line parallel with and 10.00 feet northerly (measured at right angles) from said southerly line of Outlot A; thence
- 8) North 89°47'35" West, along the last said parallel line, a distance of 63.02 feet to a line parallel with and 10.00 feet easterly (measured at right angles) from said west line of Outlot A; thence
- 9) North 00°30'57" East, along the last said parallel line, a distance of 35.07 feet to a line parallel with and 2.00 feet southeasterly (measured at right angles) from the southeasterly line of said Lot 147; thence

10) South  $57^{\circ}27'07''$  West, along the last said parallel line, a distance of 11.93 feet to the Point of Beginning.

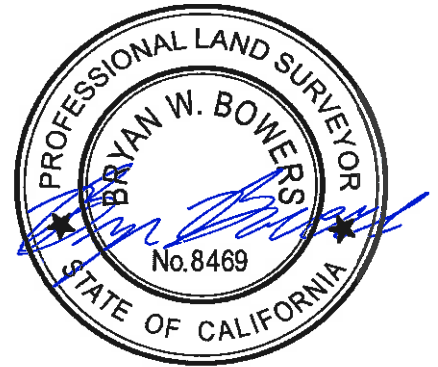

Date  
Signed 11/30/12



TRACT 821 PHASE 1  
"LIBERTY"  
VOL. 21 PG. 78, KCR

LINE TABLE		
LINE	BEARING	LENGTH
L1	S00°33'47"W	19.89
L2	N00°04'13"W	10.00
L3	N00°33'47"E	19.84
L4	N00°30'57"E	35.07
L5	S57°27'07"W	11.93

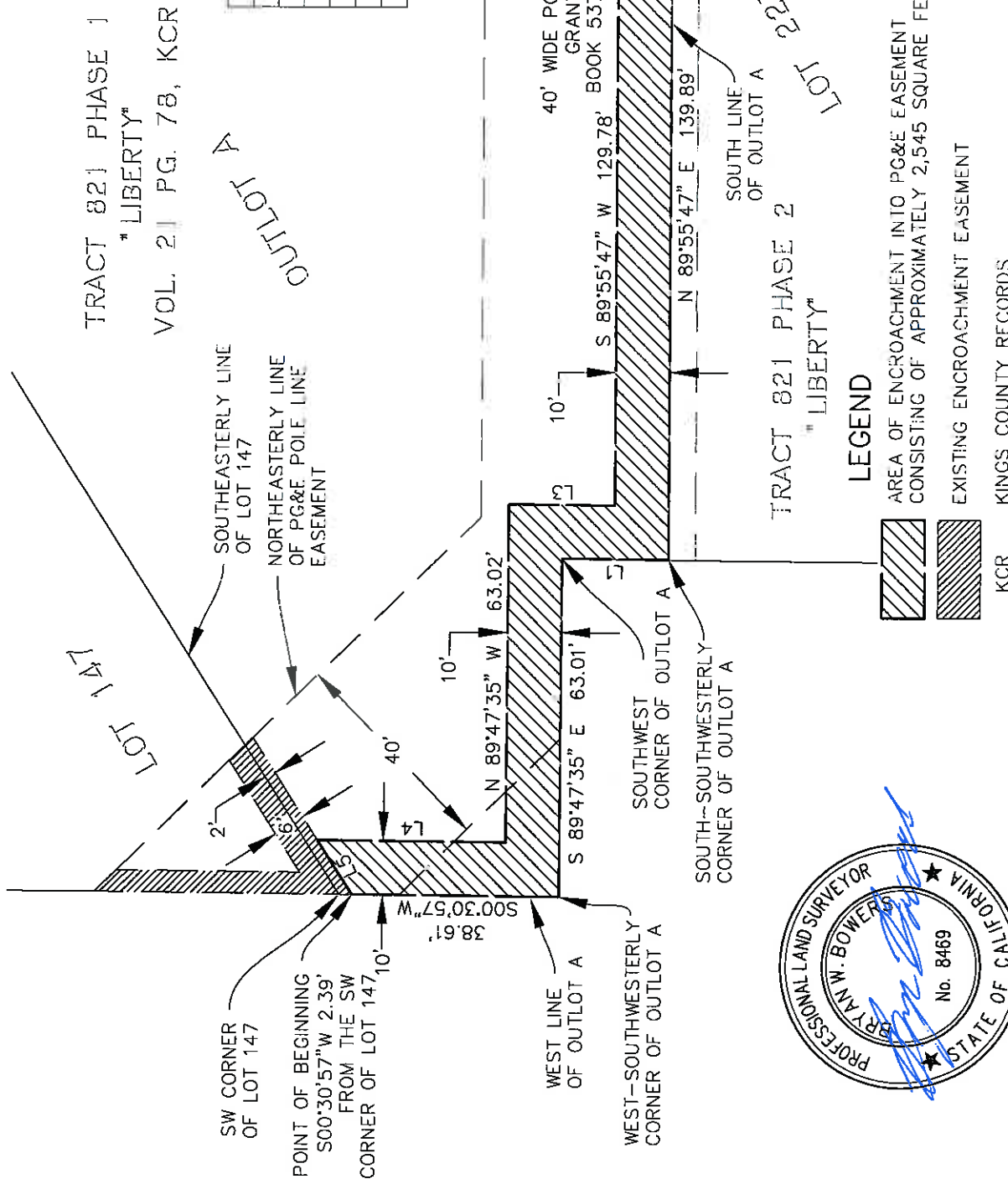

**LEGEND**

- AREA OF ENCROACHMENT INTO PG&E EASEMENT CONSISTING OF APPROXIMATELY 2,545 SQUARE FEET.
- EXISTING ENCROACHMENT EASEMENT
- KCR KINGS COUNTY RECORDS



DATE SIGNED: 11/30/12

EST. 1968  
**PROVOST & PRITCHARD**  
CONSULTING GROUP  
An Employee Owned Company

EXHIBIT "C"  
TRACT 821 PHASE 1  
OUTLOT A  
PG&E ENCROACHMENT

SURVEYOR:  
BRYAN W. BOWERS  
DATE: 11/30/12  
JOB NO: 12381201  
SHEET 1 OF 1

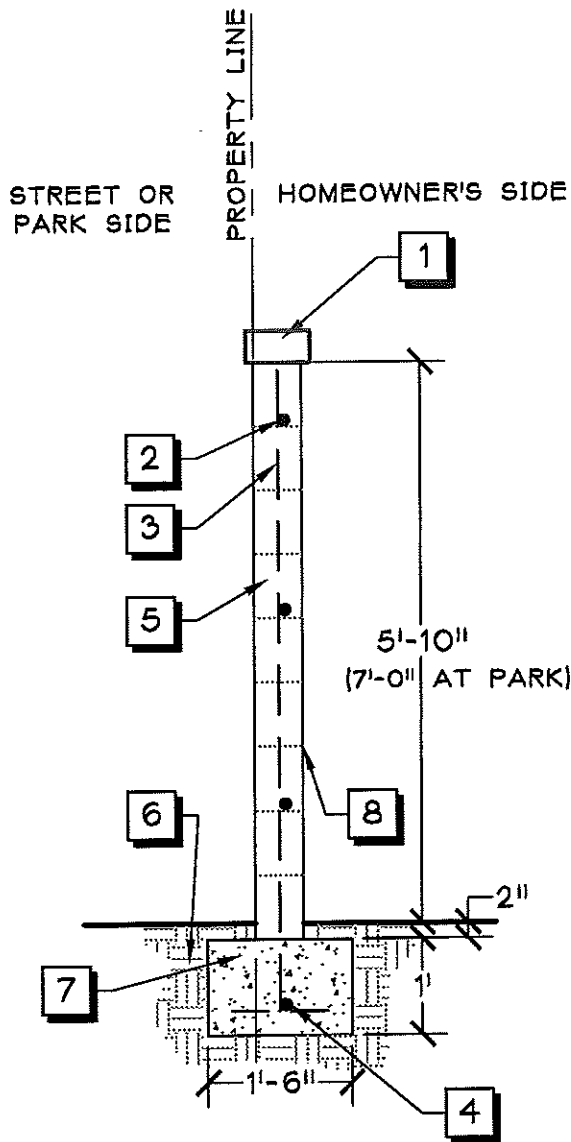

- 1 8x4x16 SLUG
- 2 #4 REBAR @24" O.C. - HORIZONTALLY
- 3 #4 REBAR @ 32" O.C. - VERTICALLY
- 4 #4 REBAR; CONT. IN FOOTING. HOLD MIN. 3" CLEAR FROM ALL EDGES OF FOOTING
- 5 6x8x16 SPLIT FACE CMU BLOCK (ONE SIDED - SPLIT FACE SIDE TO FACE STREET, TYP.) BLOCK TO BE BLOCKLITE MODEL S-193 (R)
- 6 COMPACTED SUBGRADE
- 7 CONCRETE FOOTING
- 8 RAKED GROUT JOINTS AT BACK OF WALL

**A PROJECT WALL**  
SCALE: 1/2" = 1'-0"

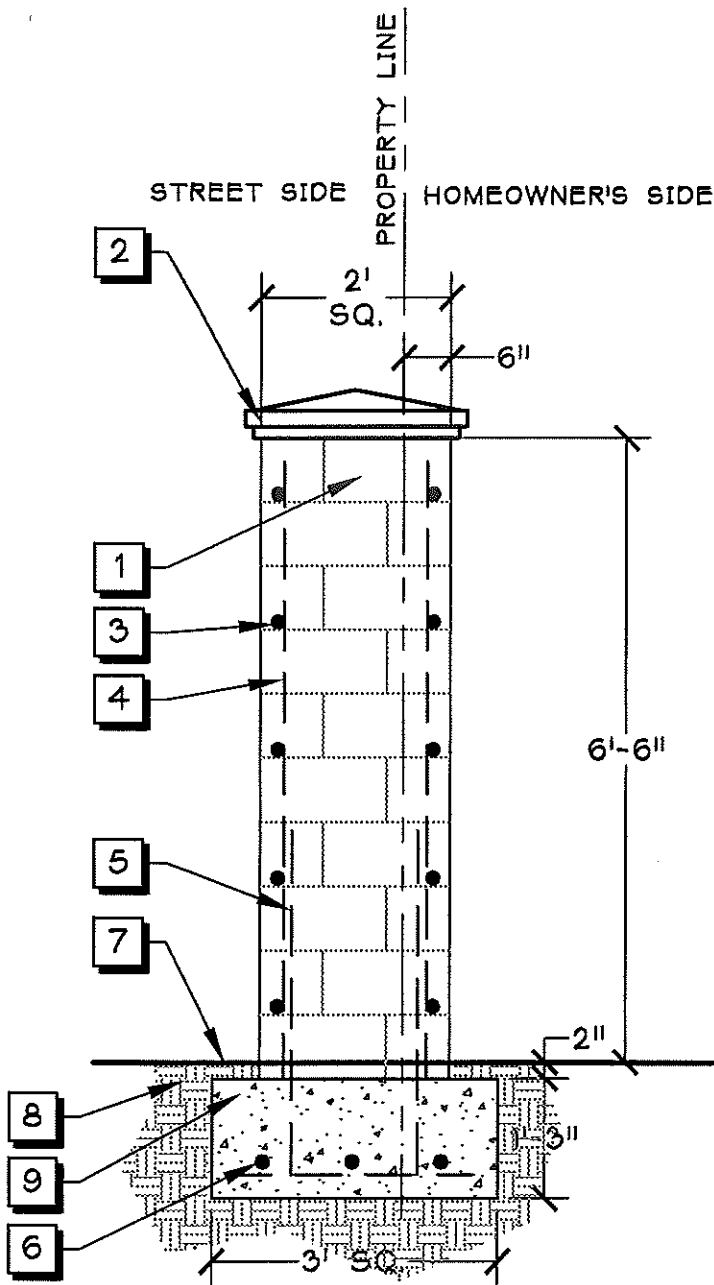

- 1 8x8x16 SPLIT FACE CMU BLOCK, BLOCKLITE MODEL S-193 (R). GROUT FILL CELLS W/ VERTICAL REINFORCEMENT SOLID
- 2 PRECAST CONCRETE CAP; MODEL PC002B (26x6x26), COLOR TO BE MESA BUFF. AVAIL. THROUGH CLOVIS STONE 298-6750
- 3 #4 REBAR @ 16" O.C. - HORIZONTALLY
- 4 #4 REBAR - VERTICALLY, (1) ONE IN EACH CORNER
- 5 #4 REBAR DOWELS, 40-BAR-DIAMETER LAP MINIMUM
- 6 (3) #4 REBAR IN FOOTING (BOTH WAYS), HOLD MIN. 3" CLEAR FROM ALL EDGES OF FOOTING
- 7 FINISHED GRADE
- 8 COMPACTED SUBGRADE
- 9 CONCRETE FOOTING

**B** PILASTERS  
 SCALE: 1/2" = 1'-0"

Advice 4202-E  
March 14, 2013

Attachment 2:  
Original Easement

AFTER RECORDATION RETURN TO  
PACIFIC GAS AND ELECTRIC CO.  
LAND DEPARTMENT  
1401 FULTON STREET  
FRESNO 21, CALIFORNIA

RECORDED AT REQUEST OF

*Pacific Gas & Electric*

AT 30 MIN. PAST 12 A.M.

MAY 17 1962 FEE \$ 2.80

VOL 808 OFFICIAL RECORDS, P. 340  
KINGS COUNTY, STATE OF CALIFORNIA

BEATRICE HAWES, Auditor and Recorder  
*Grace Fleming* DEPUTY

X

CONF- 416  
Henrietta Lemore Tolson  
2219-20-0045

COPY SENT  
TO DIVISION

HP

ALICE G. CLAWSON, a widow,

hereinafter called first party, in consideration of value adequate therefor paid by PACIFIC GAS AND ELECTRIC COMPANY, a California corporation, hereinafter called second party, the receipt whereof is hereby acknowledged, hereby grants to second party the right to erect, construct, reconstruct, replace, remove, maintain and use a line of poles with such wires as second party shall from time to time suspend therefrom for the transmission of electric energy, and for communication purposes, and all necessary and proper crossarms, guys, anchors and other appliances and fixtures for use in connection with said poles and wires, together with a right of way, on, along and in all of the hereinafter described strip of those certain lands which are situate in the \_\_\_\_\_

County of Kings, State of California, and are described as follows:

Lot 4, the E $\frac{1}{2}$  of the SW $\frac{1}{4}$  of the NW $\frac{1}{4}$ , and the E $\frac{1}{2}$  of the W $\frac{1}{2}$  of the SW $\frac{1}{4}$  of the NW $\frac{1}{4}$ , of Section 3, T. 19 S., R. 20 E., M. D. B. & M.; excepting therefrom the 1.55 acre parcel of land conveyed by Alice G. Clawson to Pacific Gas and Electric Company by deed dated April 29, 1952 and recorded in the office of the County Recorder of said County of Kings in Book 526 of Official Records at page 138.

The aforesaid strip extends entirely across said lands and is particularly described as follows:

1. A strip of land of the uniform width of 22 feet lying contiguous to and easterly of the westerly boundary line of the E $\frac{1}{2}$  of the W $\frac{1}{2}$  of the SW $\frac{1}{4}$  of the NW $\frac{1}{4}$  of said Section 3 and extending from the northerly boundary line of the county road known as Bume Avenue northerly 1255 feet, more or less, to the southerly boundary line of the strip of land described in the deed from Alice G. Clawson to Pacific Gas and Electric Company dated September 6, 1952 and recorded in the office of said County Recorder in Book 537 of Official Records at page 111.
2. Beginning at the 1 $\frac{1}{4}$  inch pipe (stamped L.S. 1969) marking the southeast corner of said 1.55 acre parcel of land and running thence N. 0° 02' E., along the easterly boundary line of said 1.55 acre parcel of land, 29.8 feet to a point in the southwesterly boundary line of the strip of land described in said deed dated September 6, 1952; thence S. 44° 46' E., along the southerly boundary line of the strip of land described in said deed dated September 6, 1952, a distance of 41.8 feet to a point in the southerly boundary line of said Lot 4; thence S. 89° 50' W., along the southerly boundary line of said Lot 4, a distance of 29.4 feet, more or less, to the point of beginning.

First party, for the consideration aforesaid, further grants to second party the right of ingress to and egress from said strip over and across said lands by means of roads and lanes thereon, if such there be, otherwise by such route or routes as shall occasion the least practicable damage and inconvenience to first party, provided, that such right of ingress and egress shall not extend to any portion of said lands which is isolated from said strip by any public road or highway, now crossing or hereafter crossing said lands.

First party shall have the right to use said strip for purposes not inconsistent with second party's full enjoyment of the rights hereby granted, provided that first party shall not erect or construct any building or other structure, or drill or operate any well, within said strip.

Second party shall have the further right to install, maintain and use gates in all fences which now cross or shall hereafter cross said strip.

Second party shall also have the right from time to time to trim and to cut down and clear away any and all trees and brush now or hereafter on said strip and shall have the further right from time to time to trim and to cut down and clear away any trees on either side of said strip which now or hereafter in the opinion of second party may be a hazard to said poles or wires by reason of the danger of falling thereon, provided, however, that all trees which second party is hereby authorized to cut and remove, if valuable for timber or wood, shall continue to be the property of first party, but all tops, lops, brush and refuse wood shall be burned or removed by second party.

Second party shall also have the right to mark the location of said strip by suitable markers set in the ground or on said poles, but said markers when set in the ground shall be placed in fences or other locations which will not interfere with any reasonable use first party shall make of said strip.

Second party shall repair any damage it shall do to first party's private roads or lanes on said lands, and shall indemnify first party against any loss and damage which shall be caused by the exercise of said ingress and egress, or by any wrongful or negligent act or omission of second party or of its agents or employees in the course of their employment.

The provisions hereof shall inure to the benefit of and bind the heirs, successors and assigns of the respective parties hereto.

IN WITNESS WHEREOF first party has executed these presents this 9th day of April 1962

Alice G. Clawson  
A-G

Executed in the presence of

Lud A. Cuen  
Witness



STATE OF CALIFORNIA  
 City and County of San Francisco ss.  
 On this 18th day of April 1962 before me, Rita J. Green, a Notary Public in and for said County, duly commissioned and sworn, personally appeared Fred A. Cuen known to me to be the same person whose name is subscribed to the within instrument, who, being duly sworn, deposed and said, that he resides in the County of San Mateo, State of California, that he was present and saw Alice G. Clawson (personally known to him to be the person described in and who executed the said instrument, as part thereof), sign and execute the same, and that he thereupon subscribed his name as a witness thereto.  
 IN WITNESS WHEREOF, I have hereunto set my hand and affixed my official seal in the said City of San Francisco, the day and year in the certificate first above written.  
 My Commission Expires July 16, 1963  
 Rita J. Green  
 Notary Public in and for the County of San Francisco, State of California

San Joaquin  
G.M. 150391  
Dwg. 212385  
Section 3,  
T.19S., R.20E.,  
M.D.B. & M.  
67

Prepared by WGD  
Checked by J. Cuen



First party, for the consideration aforesaid, further grants to second party, the right of ingress to and egress from said strip over and across said lands by means of roads and lanes thereon, if such there be, otherwise by such route or routes as shall occasion the least practicable damage and inconvenience to first party, provided, that such right of ingress and egress shall not extend to any portion of said lands which is isolated from said strip by any public road or highway, now crossing or hereafter crossing said lands.

First party shall have the right to use said strip for purposes not inconsistent with second party's full enjoyment of the rights hereby granted, provided that first party shall not erect or construct any building or other structure, or drill or operate any well, within said strip.

Second party shall have the further right to install, maintain and use gates in all fences which now cross or shall hereafter cross said strip.

Second party shall also have the right from time to time to trim and to cut down and clear away any and all trees and brush now or hereafter on said strip and shall have the further right from time to time to trim and to cut down any trees on either side of said strip which now or hereafter in the opinion of second party may be a hazard to said poles or wires by reason of the danger of falling thereon, provided, however, that all trees which second party is hereby authorized to cut and remove, if valuable for timber or wood, shall continue to be the property of first party, but all tops, lops, brush and refuse wood shall be burned or removed by second party.

Second party shall also have the right to mark the location of said strip by suitable markers set in the ground or on said poles, but said markers when set in the ground shall be placed in fences or other locations which will not interfere with any reasonable use first party shall make of said strip.

Second party shall repair any damage it shall do to first party's private roads or lanes on said lands, and shall indemnify first party against any loss and damage which shall be caused by the exercise of said ingress and egress, or by any wrongful or negligent act or omission of second party or of its agents or employees in the course of their employment.

The provisions hereof shall inure to the benefit of and bind the heirs, successors and assigns of the respective parties hereto.

IN WITNESS WHEREOF first party has executed these presents this 6<sup>th</sup> day of

September 19 52

Alvin G. Clanson

Executed in the presence of  
R. H. Taylor  
Witness

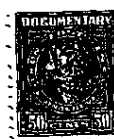

PREPARED ms  
CHECKED DS  
86 AUG 23 '52

*Handwritten initials*



RECEIVED  
KINGS COUNTY STATE OF CALIFORNIA  
VALS 537 OFFICIAL RECORDS P. 111

9 200 OCT - 3 1952  
FEE

RECORDED AT REQUEST OF  
H. 52 Min. Fee 70.00  
[Signature]

22-40228 2-22 180 FOR.

State of California }  
County of Fresno } ss. BOOK 537 PAGE 113

On this 8th day of September A. D. One Thousand Nine Hundred and Fifty-two, before me, R. L. Bressler a Notary Public in and for said Fresno County, residing therein, duly commissioned and sworn, personally appeared R. G. Tyler known to me to be the same person whose name is subscribed to the within instrument, as a witness thereto, who, being duly sworn, deposed and said, that he resides in the Fresno County of State of California, that he was present and saw



Fresno  
Alice G. Clawson  
(personally known to him to be the person described in and who executed the said instrument, as party thereto), sign and execute the same, and that, at her request, he, the said affiant, thereupon subscribed his name as a witness thereto.

In Witness Whereof, I have hereunto set my hand and affixed my official seal, at my office, in the said Fresno County of Fresno the day and year in this certificate first above written.

[Signature]  
Notary Public in and for the Fresno County of Fresno, State of California  
My Commission Expires July 21, 1953

PROJECT Hanford-Lemoore to 608-d.  
AUTHORIZATION 600 116 794  
COST \$ 800 00

DRAFT No. 14349  
MAP No. Sheet 1  
COPY TO San Joaquin Division

Advice 4202-E  
March 14, 2013

Attachment 3:  
Final Mitigated Negative Declaration

**CITY OF LEMOORE**

**NEGATIVE DECLARATION NO.2004-25**

---

**Project: Zone Change No.2004-02; Vesting Tentative Subdivision Map No.2004-05/Planned Unit Development No.2004-03/Conditional Use Permit No.2004-08**

**Description**

Zone Change No.2004-02 and Vesting Tentative Subdivision Map No.2004-05/Planned Unit Development No.2004-03/Conditional Use Permit No.2004-08, application by Lennar Fresno, Inc. to remove the existing structures and subdivide Tract No.821, consisting of approximately 68 acres into 238 single family lots, in two phases. The subject tract is north of Cinnamon Drive, south of Hanford-Armona Road, east of 19<sup>th</sup> Avenue and west of Liberty Drive. Ingress/egress to the development is from Hanford-Armona Road, 19<sup>th</sup> Avenue, Cinnamon Drive and Liberty Drive. The minimum lot size is proposed to be 7,000 sq. ft. and the average lot size is to be 8,479 sq. ft. The site is currently zoned UR (Urban Reserve) in accordance to the provisions of the Lemoore Municipal Code. The site is described as Assessor Parcel No.021-620-001.

The Zone Change is proposed to change the zone classification of the above described 68 acre site from UR(Urban Reserve) to R-1-7PUD(Single Family Residential, Planned Unit Development).

**Finding:**

The proposed project is in conformance with all Codes, Ordinances and regulations of the City of Lemoore and will not have a significant effect on the environment.

**Preparation of Study**

The Initial Study of this proposal was undertaken by the Staff of the City of Lemoore. Copies may be obtained from the Community Development Office of the City of Lemoore, 406 "B" Street, Lemoore, California 93245.



# Kings County Planning and Inspections

## Receipt of Fees

Receipt Number: 2006090

Receipt Date: 2/22/2005

Building Permit:

Check Or Cash: CH

Check Number: 2229

Planning Permit:

Received From: Zumwalt Hansen, Inc. NOD

Received By:

*Mark La*

<u>DESCRIPTION</u>	<u>Fund</u>	<u>Dept</u>	<u>Acct Number</u>	<u>AMOUNT</u>
PLANNING SERVICES		2700	816361	25.00
DFG CLERK FEE (\$25.00)		2720	816100	25.00
			<b>Amount Paid</b>	<b>50.00</b>

# ENVIRONMENTAL CHECKLIST FORM

## FOR THE CITY OF LEMOORE

1. Project Title: Tract 821 – Tentative Subdivision Map No. 2004-25/PUD No. 2004-03/ CUP No. 2004-08/
2. Lead Agency Name and Address: City of Lemoore, 210 Fox Street, Lemoore California 93245
3. Contact Person and Phone Number: Holly Smyth (559) 924-6740
4. Project Location: South of Hanford-Armona Road, west of Liberty Drive, North of Cinnamon Drive and east of 19<sup>th</sup> Avenue
5. Project Sponsor's Name and Address: Lennar Fresno, Inc. 7690 N. Palm, #101, Fresno, CA 93711
6. General Plan Designation: Low-Medium density residential
7. Zone District: Requesting an amendment to the Zoning Ordinance from Urban Reserve to R-1-7 (PUD)
8. Description of Project: Subdivide and develop approximately 75 acres into 238 single family lots, in two phases
9. Surrounding Land Uses and Setting: Single family residential/mobile homes/light agriculture uses to the north, residential and middle school to the east, municipal offices, Sports Complex and industrial uses to the south, and residential, PG&E substation, and Lemoore Elementary School District Offices (home to future elementary school) to the west
10. Other public agencies whose approval is required: None

### ENVIRONMENTAL FACTORS POTENTIALLY AFFECTED:

(The environmental factors checked below would be potentially affected by this project, involving at least one impact that is a "Potentially Significant Impact" as indicated by the checklist on the following pages.)

	Aesthetics	X	Agricultural Resources	X	Air Quality
	Biological Resources	XX	Cultural Resources		Geology/Soils
	Hazards & Hazardous Materials	X	Hydrology/Water Quality		Land Use/Planning
	Mineral Resources		Noise	X	Population/Housing
XX	Public Services		Recreation	XX	Transportation/Traffic
	Utilities/Service Systems		Mandatory Findings of Significance		

### DETERMINATION - On the basis of this initial evaluation:

(To be completed by the Lead Agency)

- I find that the proposed project COULD NOT have a significant effect on the environment, and a NEGATIVE DECLARATION will be prepared.
- I find that although the proposed project could have a significant effect on the environment, there will not be a significant effect in this case because the mitigation measures described on an attached sheet have been added to the project. A MITIGATED NEGATIVE DECLARATION will be prepared.
- I find that the proposed project MAY have a significant effect on the environment, and an ENVIRONMENTAL IMPACT REPORT is required.
- I find that the proposed project MAY have a "potentially significant impact" or "potentially significant unless mitigated" impact on the environment, but at least one effect 1) has been adequately analyzed in an earlier document pursuant to applicable legal standards, and 2) has been addressed by mitigation measures based on the earlier analysis as described on attached sheets, if the effect is a "potentially significant impact" or "potentially significant unless mitigated." An ENVIRONMENTAL IMPACT REPORT is required, but it must analyze only the effects that remain to be addressed.
- I find that although the proposed project could have a significant effect on the environment, there WILL NOT be a significant effect in this case because all potentially significant effects (a) have been analyzed adequately in an earlier EIR pursuant to applicable standards and (b) have been avoided or mitigated pursuant to that earlier EIR or NEGATIVE DECLARATION, including revisions or mitigation measures that are imposed upon the proposed project, nothing further is required.

Signature

Holly P. Smyth

Printed Name

December 27, 2004

Date

City of Lemoore

For

# EVALUATION OF ENVIRONMENTAL IMPACTS:

- 1) A brief explanation is required for all answers except "No Impact" answers that are adequately supported by the information sources a lead agency cites in the parentheses following each question. A "No Impact" answer is adequately supported if the referenced information sources show that the impact simply does not apply to project like the one involved (e.g., the project falls outside a fault rupture zone). A "No Impact" answer should be explained where it is based on project-specific factors as well as general standards (e.g., the project will not expose sensitive receptors to pollutants, based on a project-specific screening analysis).
- 2) All answers must take account of the whole action involved, including off-site as well as on-site, cumulative as well as project-level, indirect as well as direct, and construction as well as operational impacts.
- 3) Once the lead agency has determined that a particular physical impact may occur, then the checklist answers must indicate whether the impact is potentially significant, less than significant with mitigation, or less than significant. "Potentially Significant Impact" is appropriate if there is substantial evidence that an effect may be significant. If there are one or more "Potentially Significant Impact" entries when the determination is made, an EIR is required.
- 4) "Negative Declaration: Less Than Significant With Mitigation Incorporated" applies where incorporation of mitigation measures has reduced an effect from "Potentially Significant Impact" to a "Less Than Significant Impact." The lead agency must describe the mitigation measures, and briefly explain how they reduce the effect to a less than significant level (mitigation measures from Section XVII; "Earlier Analyses," may be cross-referenced).
- 5) Earlier analyses may be used where, pursuant to the tiering, program EIR, or other CEQA process, an effect has been adequately analyzed in an earlier EIR or negative declaration. Section 15063(c)(3)(D). In this case, a brief discussion should identify the following:
  - a) Earlier Analysis Used. Identify and state where they are available for review.
  - b) Impacts Adequately Addressed. Identify which effect from the above checklist were within the scope of and adequately analyzed in an earlier document pursuant to applicable legal standards, and state whether such effects were addressed by mitigation measures based on earlier analysis.
  - c) Mitigation Measures. For effects that are "Less than Significant with Mitigation Measures Incorporated," describe the mitigation measures which were incorporated or refined from the earlier document and the extent to which they address site-specific conditions for the project.
- 6) Lead agencies are encouraged to incorporate into the checklist references to information sources for potential impacts (e.g., general plans, zoning ordinances). Reference to a previously prepared or outside document should, where appropriate, include a reference to the page or pages where the statement is substantiated.
- 7) Supporting Information Sources: A source list should be attached, and other sources used or individuals contacted should be cited in the discussion.
- 8) This is only a suggested form, and lead agencies are free to use different formats; however, lead agencies should normally address the questions from this checklist that are relevant to a project's environmental effects in whatever format is selected.
- 9) The explanation of each issue should identify:
  - a) the significance criteria or threshold, if any, used to evaluate each question; and
  - b) the mitigation measure identified, if any, to reduce the impact to less than significance.

Potentially Significant Impact	Potentially Significant Unless Mitigation Incorporation	Less Than Significant Impact	No Impact
--------------------------------	---	------------------------------	-----------

## I. AESTHETICS - Would the project:

- a) Have a substantial adverse effect on a scenic vista?
- b) Substantially damage scenic resources, including, but not limited to, trees, rock, outcroppings, and historic buildings within a state scenic highway?
- c) Substantially degrade the existing visual character or quality of the site and its surroundings?
- d) Create a new source of substantial light or glare which would adversely affect day or nighttime views in the area?

			XX
			XX
			XX
			XX

## II. AGRICULTURAL RESOURCES - Would the project:

(Note: In determining whether impacts to agricultural resources are significant environmental effects, lead agencies may refer to the *California Agricultural Land Evaluation and Site Assessment Model* (1997) prepared by the California Dept. of Conservation as an optional model to use in assessing impacts on agriculture and farmland.)

- a) Convert Prime Farmland, Unique Farmland, or Farmland of Statewide Importance (Farmland), as shown on the maps prepared pursuant to the Farmland Mapping and Monitoring Program of the California Resources Agency, to non-agricultural use?
- b) Conflict with existing zoning for agricultural use, or a Williamson Act contract?
- c) Involve other changes in the existing environment which, due to their location or nature, could result in conversion of Farmland, to non-agricultural use?

		XX	
			XX
		XX	

**III. AIR QUALITY - Would the project:**

- a) Conflict with or obstruct implementation of the applicable air quality plan?
- b) Violate any air quality standard or contribute substantially to an existing or projected air quality violation?
- c) Result in cumulatively considerable net increase of any criteria pollutant for which the project region is non-attainment under an applicable federal or state ambient air quality standard (including releasing emissions which exceed quantitative thresholds for ozone precursors)?
- d) Expose sensitive receptors to substantial pollutant concentrations?
- e) Create objectionable odors affecting a substantial number of people?

Potentially Significant Impact	Potentially Significant Unless Mitigation Incorporation	Less Than Significant Impact	No Impact
			XX
		XX	
			XX
		XX	
			XX

**IV. BIOLOGICAL RESOURCES - Would the project:**

- a) Have a substantial adverse effect, either directly or through habitat modifications, on any species identified as a candidate, sensitive, or special status species in local or regional plans, policies, or regulations or by the California Dept. of Fish & Game or US Fish & Wildlife Service?
- b) Have a substantial adverse effect on any riparian habitat or other sensitive natural community identified in local or regional plans, policies, or regulations or by the California Dept. of Fish & Game or US Fish & Wildlife Service?
- c) Have a substantial adverse effect on federally protected wetlands as defined by Section 404 of the Clean Water Act (including, but not limited to, marsh, vernal pool, coastal, etc.) through direct removal, filling, hydrological interruption, or other means?
- d) Interfere substantially with the movement of any native resident or migratory fish or wildlife species or with established native resident or migratory wildlife corridors, or impede the use of native wildlife nursery sites?
- e) Conflict with any local policies or ordinances protecting biological resources, such as a tree preservation policy or ordinance?
- f) Conflict with the provisions of an adopted Habitat Conservation Plan, Natural Community Conservation Plan, or other approved local, regional, or state habitat conservation plan?

			XX
			XX
			XX
			XX
			XX
			XX

**V. CULTURAL RESOURCES - Would the project:**

- a) Cause a substantial adverse change in the significance of a historical resource as defined in Section 15064.5?
- b) Cause a substantial adverse change in the significance of an archaeological resource pursuant to Section 15064.5?
- c) Directly or indirectly destroy a unique paleontological resource or site or unique geologic feature?
- d) Disturb any human remains, including those interred outside of formal cemeteries?

	XX		
			XX
			XX
			XX

**VI. GEOLOGY AND SOILS - Would the project:**

Potentially Significant Impact	Potentially Significant Unless Mitigation Incorporation	Less Than Significant Impact	No Impact
--------------------------------	---	------------------------------	-----------

- a) Expose people or structures to potential substantial adverse effects, including the risk of loss, injury, or death involving:
  - i) Rupture of a known earthquake fault, as delineated on the most recent Alquist-Priolo Earthquake Fault Zoning Map issued by the State Geologist for the area or based on other substantial evidence of a known fault? (Refer to *Division of Mines & Geology Special Publication 42.*)
  - ii) Strong seismic ground shaking?
  - iii) Seismic-related ground failure, including liquefaction?
  - iv) Landslides?
- b) Result in substantial soil erosion or the loss of topsoil?
- c) Be located on a geologic unit or soil that is unstable, or that would become unstable as a result of the project, and potentially result in on- or off-site landslide, lateral spreading, subsidence, liquefaction or collapse?
- d) Be located on expansive soil, as defined in Table 18-1-B of the Uniform Building Code (1997), creating substantial risks to life or property?
- e) Have soils incapable of adequately supporting the use of septic tanks or alternative waste water disposal systems where sewers are not available for the disposal of waste water?

			XX
--	--	--	----

			XX
			XX
			XX
			XX
			XX

			XX
--	--	--	----

			XX
--	--	--	----

**VII. HAZARDS AND HAZARDOUS MATERIALS - Would the project:**

- a) Create a significant hazard to the public or the environment through the routine transport, use, or disposal of hazardous materials?
- b) Create a significant hazard to the public or the environment through reasonably foreseeable upset and accident conditions involving the release of hazardous materials into the environment?
- c) Emit hazardous emissions or handle hazardous or acutely hazardous materials, substances, or waste within one-quarter mile of an existing or proposed school?
- d) Be located on a site which is included on a list of hazardous materials sites compiled pursuant to Government Code Section 65962.5 and, as a result, would it create a significant hazard to the public or the environment?
- e) For a project located within an airport land use plan or, where such a plan has not been adopted, within two miles of a public airport or public use airport, would the project result in a safety hazard for people residing or working in the project area?
- f) For a project within the vicinity of a private airstrip, would the project result in a safety hazard for people residing or working in the project area?
- g) Impair implementation of or physically interfere with an adopted emergency response plan or emergency evacuation plan?
- h) Expose people or structures to a significant risk or loss, injury or death involving wildland fires, including where wildlands area adjacent to urbanized areas or where residences are intermixed with wildlands?

			XX
--	--	--	----

			XX
--	--	--	----

			XX
--	--	--	----

			XX
--	--	--	----

			XX
--	--	--	----

			XX
--	--	--	----

			XX
--	--	--	----

			XX
--	--	--	----



**VIII. HYDROLOGY AND WATER QUALITY - Would the project:**

Potentially Significant Impact	Potentially Significant Unless Mitigation Incorporation	Less Than Significant Impact	No Impact
			XX

- a) Violate any water quality standards or waste discharge requirements?
- b) Substantially deplete groundwater supplies or interfere substantially with groundwater recharge such that there would be a net deficit in aquifer volume or a lowering of the local groundwater table level (e.g., the production rate of pre-existing nearby wells would drop to a level which would not support existing land uses or planned uses for which permits have been granted.)?
- c) Substantially alter the existing drainage pattern of the site or area, including through the alteration of the course of a stream or river, in a manner which would result in substantial erosion or siltation on- or off-site?
- d) Substantially alter the existing drainage pattern of the site or area, including through the alteration of the course of a stream or river, or substantially increase the rate or amount of surface runoff in a manner which would result in flooding on- or off-site?
- e) Create or contribute runoff water which would exceed the capacity of existing or planned stormwater drainage systems or provide substantial additional sources of polluted runoff?
- f) Otherwise substantially degrade water quality?
- g) Place housing within a 100-year flood hazard area as mapped on a federal Flood Hazard Boundary or Flood Insurance Rate Map or other flood hazard delineation map?
- h) Place housing within a 100-year flood hazard area structures which would impede or redirect flood flows?
- i) Expose people or structures to a significant risk of loss, injury or death involving flooding, including flooding as a result of the failure of a levee or dam?
- j) Inundation by seiche, tsunami, or mudflow?

			XX
--	--	--	----

			XX
--	--	--	----

		XX	
--	--	----	--

			XX
--	--	--	----

			XX
--	--	--	----

			XX
--	--	--	----

			XX
--	--	--	----

			XX
--	--	--	----

			XX
--	--	--	----

**IX. LAND USE AND PLANNING - Would the project:**

- a) Physically divide an established community?
- b) Conflict with any applicable land use plan, policy, or regulation of an agency with jurisdiction over the project (including, but not limited to the general plan, specific plan, local coastal program, or zoning ordinance) adopted for the purpose of avoiding or mitigating an environmental effect?
- c) Conflict with any applicable habitat conservation plan or natural community conservation plan?

			XX
--	--	--	----

			XX
--	--	--	----

			XX
--	--	--	----

**X. MINERAL RESOURCES - Would the project:**

- a) Result in the loss of availability of a known mineral resource that would be of value to the region and the residents of the state?
- b) Result in the loss of availability of a locally-important mineral resource recovery site delineated on a local general plan, specific plan or other land use plan?

			XX
--	--	--	----

			XX
--	--	--	----

**XI. NOISE - Would the project result in:**

- a) Exposure of persons to or generation of noise levels in excess of standards established in the local general plan or noise ordinance, or applicable standards of other agencies?

			XX
--	--	--	----

**XI. NOISE - Would the project result in: (cont.)**

- b) Exposure of persons to or generations of excessive ground-borne vibration or ground-borne noise levels?
- c) A substantial permanent increase in ambient noise levels in the project vicinity above levels existing without the project?
- d) A substantial temporary or periodic increase in ambient noise levels in the project vicinity above levels existing without the project?
- e) For a project located within an airport land use plan or, where such a plan has not been adopted, within two miles of a public airport or public use airport, would the project expose people residing or working in the project area to excessive noise levels?
- f) For a project within the vicinity of a private airstrip, would the project expose people residing or working in the project area to excessive noise levels?

Potentially Significant Impact	Potentially Significant Unless Mitigation Incorporation	Less Than Significant Impact	No Impact
			XX
			XX
			XX
			XX
			XX

**XII. POPULATION AND HOUSING - Would the project:**

- a) Induce substantial population growth in an area, either directly (for example, by processing new homes and businesses) or indirectly (for example, through extension of roads or other infrastructure)?
- b) Displace substantial numbers of existing housing necessitating the construction of replacement housing elsewhere?
- c) Displace substantial numbers of people, necessitating the construction of replacement housing elsewhere?

		XX	
			XX
			XX

**XIII. PUBLIC SERVICES**

- a) Would the project result in substantial adverse physical impacts associated with the provision of new or physically altered governmental facilities, need for new or physically altered governmental facilities, the construction of which could cause significant environmental impacts, in order to maintain acceptable service ratios, response times or other performance objectives for any of the public services:
  - i) Fire protection?
  - ii) Police protection?
  - iii) Schools?
  - iv) Parks?
  - v) Other public facilities?

		XX	
			XX
	XX		
			XX
			XX

**XIV. RECREATION**

- a) Would the project increase the use of existing neighborhood and regional parks or other recreational facilities such that substantial physical deterioration of the facility would occur or be accelerated?
- b) Does the project include recreational facilities or require the construction or expansion of recreational facilities which might have been an adverse physical effect on the environment?

			XX
			XX

**XV. TRANSPORTATION/TRAFFIC - Would the project:**

Potentially Significant Impact	Potentially Significant Unless Mitigation Incorporation	Less Than Significant Impact	No Impact
	XX		

- a) Cause an increase in traffic which is substantial in relation to the existing traffic load and capacity of the street system (i.e., result in a substantial increase in either the number of vehicle trips, the volume to capacity ratio on roads, or congestion at intersections.)?
- b) Exceed, either individually or cumulatively, a level of service standard established by the county congestion management agency for designated roads or highways?
- c) Result in a change in air traffic patterns, including either an increase in traffic levels or a change in location that results in substantial safety risks?
- d) Substantially increase hazards due to a design feature (e.g., sharp curves or dangerous intersections) or incompatible uses (e.g., farm equipment)?
- e) Result in inadequate emergency access?
- f) Result in inadequate parking capacity?
- g) Conflict with adopted policies, plans, or programs supporting alternative transportation (e.g., bus turnouts, bicycle racks)?

	XX		
--	----	--	--

			XX
--	--	--	----

			XX
--	--	--	----

			XX
--	--	--	----

			XX
--	--	--	----

			XX
--	--	--	----

**XVI. UTILITIES AND SERVICE SYSTEMS - Would the project:**

- a) Exceed wastewater treatment requirements of the applicable Regional Water Quality Control Board?
- b) Require or result in the construction of new water or wastewater treatment facilities or expansion of existing facilities, the construction of which could cause significant environmental effects?
- c) Require or result in the construction of new storm water drainage facilities or expansion of existing facilities, the construction of which could cause significant environmental effects?
- d) Have sufficient water supplies available to serve the project from existing entitlements and resources, or are new or expanded entitlements needed?
- e) Result in a determination by the wastewater treatment provider which serves or may serve the project that it has adequate capacity to serve the project's projected demand in addition to the provider's existing commitments?
- f) Be served by a landfill with sufficient permitted capacity to accommodate the project's solid waste disposal needs?
- g) Comply with federal, state, and local statutes and regulations related to solid waste?

			XX
--	--	--	----

			XX
--	--	--	----

			XX
--	--	--	----

			XX
--	--	--	----

			XX
--	--	--	----

			XX
--	--	--	----

			XX
--	--	--	----

**XVII. MANDATORY FINDINGS OF SIGNIFICANCE**

- a) Does the project have the potential to degrade the quality of the environment, substantially reduce the habitat of a fish or wildlife species, cause a fish or wildlife population to drop below self-sustaining levels, threaten to eliminate a plant or animal community, reduce the number or restrict the range of a rare or endangered plant or animal or eliminate important examples of the major periods of California history or pre-history?
- b) Does the project have impacts that are individually limited, but cumulatively considerable? ("Cumulatively considerable" means that the incremental effects of a project are considerable when viewed in connection with the effects of past projects, the effects of other current projects, and the effects of probable future projects.)?
- c) Does the project have environmental effects which will cause substantial adverse effects on human beings, either directly or indirectly?

Potentially Significant Impact	Potentially Significant Unless Mitigation Incorporation	Less Than Significant Impact	No Impact
			XX

			XX
--	--	--	----

			XX
--	--	--	----

## EXPLANATION OF OTHER THAN "NO IMPACT" RESPONSES

Item IIa. Almost the entire project area is designated as "Prime Farmland" or "Farmland of Statewide Importance" by the California Department of Conservation division of Land Resource Protection who runs the farmland mapping and monitoring program. These areas are comprised of Nord soils, which yield high productivity of cotton, barley, alfalfa hay, walnuts, and pistachios and have a comparatively better capability of developing recreational areas.

This project area has not been in agricultural production for a number of years, is surrounded on three sides by existing urban development, and was anticipated to convert to single family residential units in the Lemoore General Plan at a time when most residentially designated land was already developed, therefore, development of this land should be allowed.

Item IIc. The project is located adjacent to AL-10 zoned County territory. As such, the Kings County Planning requires all land adjacent to agriculturally zoned areas to record a notice and disclosure statement which states that neighboring residents should be prepared for the inherent and potential inconveniences and discomforts often associated with normal and usual agricultural activities and operations, and the County will not take any nuisance abatement actions against any normal and usual farming operations. This helps farmers to continue their right-to-farm.

Item IIIb. During the construction of the project considerable dust will be created. Therefore, the project must conform to the San Joaquin Valley Air Pollution Control District and the City of Lemoore air quality measures.

Item IIIc. The project will be located within 1 mile of industrially zoned property, therefore the City requires that a noise and odor easement be recorded and will be required as a condition of approval.

Item Va. The project site contains the Hi Clawson home built in 1916 with a tower, milking barn and other ancillary structures. The home is one of six Lemoore home sites listed in the a Kings County historic book. It is thought that the home structure may be one of the few, if only, remaining structures in the area made of a brick that was produced locally to incorporate special air cavities to create better insulation properties. Because the City cannot demonstrate evidence that the building is not historically or culturally significant the property must be treated as if it is historically significant, as per section 15064.5(a)(2) of the California Environmental Quality Act.

The proposed project proposes to demolish the home site and all ancillary buildings. In order to mitigate the impact to be less than significant the following measures should be inacted:

- The subdivision map shall be altered to align the parcel lines to try to retain as much of the original homesite as possible.
- The house shall be placed on the real estate market for sale at a "fair market" value as soon as possible. No consideration will be made by the City to issue a demolition permit until the last homes are being built in Phase II and it is proven that all efforts were made to sell the homesite.
- If the home or other ancillary buildings are demolished a full pictorial record should be made of all exterior and interior components for the Sarah A. Mooney Museum historic records.

Item VIIIc. The project will convert existing raw land into residential development causing impervious surface areas and increase surface runoff. This will be handled through the design and building of a storm drainage system for the proposed development adequate to prevent on or off-site flooding to be submitted with the improvement plans.

Item XIIa. The project will create 238 single family housing lots, causing an increase in population by 728 persons over the life of the project. The impact to surrounding infrastructure is partially offset by the payment of impact fees.

Item XIIIa. All City services will be impacted by the large population growth. An interior pocket park will be provided to offset some of the impacts to recreation services. Impact fees will be collected to help to offset other impacts.

Item XIIIa.iii. The southerly half of the proposed subdivision does not have pedestrian access to a future elementary school site which has already developed a site plan. In order to mitigate the impact to be less than significant, a access point needs to be provided to 19th Avenue for the 92 homes in Phase II south of the PG& E site and north of the school's proposed loading and unloading zone.

Item XVa. and XVb. The project is anticipated to generate approximately 2,380 trips per day and approximately 238 peak hour trips which will enter and exit through the proposed seven (7) access points onto collector and arterial streets.

According to the General Plan it was anticipated that the following improvements would have to be carried out in the vicinity of this proposed project:

- That 19th Avenue would need to be built to accommodate four (4) 12' traffic lanes and bikeways along the road but off the road pavement between "D" Street and Hanford-Armona Road by 2010. (This was based on the existing two-lane road carrying 6,000 cars per day with 1,000 cars during the peak hour.)
- That Hanford-Armona Road would need to be increased to four lanes of traffic rather than two by the year 2000. (This was based on the existing street two-lane road carrying 9,000 cars per day with a 900 cars during the peak hour.)

Looking at data provided in a traffic impact study (TIS) conducted by Peters Engineering in April of 2003 for the adjacent College Park subdivision, which is approximately the same size and scale of the proposed subdivision, it seemed that the above anticipated improvements may now be warranted with the installation of this project. This same TIS also stated the following improvements were probably needed by 2015, which probably accounted for this 75 acre proposed subdivision developing as follows:

- Widen Hanford-Armona Road from one to two lanes in each direction prior to the year 2015 from State Route 41 to east of Liberty Drive.
- Construct a minimum 100' long westbound left-turn lane into streets within their subdivision from Hanford-Armona Road.
- 19th Avenue at Hanford-Armona Road should provide adequate room and paving at the intersection to accommodate a future signal at this location which will include a westbound left turn lane when Hanford-Armona Road is widened to two lanes in each direction.

In order to fully mitigate the possible anticipated traffic impacts listed above to be less than significant, a traffic study needs to be conducted to identify any necessary mitigation measures that must be implemented with the building of this project and by 2015 along collector and arterial streets to insure that the Level Of Service does not dip below City standards and the carrying capacity is not exceeded.

Advice 4202-E  
March 14, 2013

Attachment 4:  
City's Council Issued Resolution 2005-08

**RESOLUTION NO. 2005-08**

**A RESOLUTION OF THE CITY COUNCIL OF THE  
CITY OF LEMOORE APPROVING VESTING TENTATIVE MAP NO.2004-05/  
PLANNED UNIT DEVELOPMENT NO.2004-03/ CONDITIONAL USE PERMIT NO.2004-08  
FOR LENNAR FRESNO, INC.**

At a Regular Meeting of the City Council of the City of Lemoore duly called and held on February 15 2005, at 7:30 p.m. on said day, it was moved by Councilmember Andreasen, seconded by Councilmember Martin and carried that the following Resolution be adopted:

**WHEREAS**, Lennar Fresno, Inc. has submitted an application for Tentative Subdivision Map/ Planned Unit Development / Conditional Use Permit to remove the existing structures and subdivide and develop Tract 821 consisting of 68.16 acres into 238 single family lots, in two phases; and

**WHEREAS**, the tract on which the development is proposed is located south of Hanford-Armona Road, west of Liberty Drive, north of Cinnamon Drive, and east of 19<sup>th</sup> Avenue and is described as Assessor Parcel No.021-620-001; and

**WHEREAS**, the Lemoore Planning Commission held a duly noticed public hearing on January 24, 2005, on the above-stated proposal as required by the City of Lemoore Municipal Code, it being established that all notice requirements as set forth in Section 9-15B-2C of the said code have been complied with; and

**WHEREAS**, the Planning Commission reviewed the Environmental Impact Assessment pertinent to the proposal and determined that it will not have any significant effect on the environment and recommended that the Council adopt a Mitigated Negative Declaration pursuant to California Environmental Quality Act, as amended; and

**WHEREAS**, Section 9-15B-2G of the Lemoore Municipal Code requires the City Council to review the decision of the Planning Commission on a Vesting Tentative Subdivision Map / Planned Unit Development / Conditional Use Permit proposal in a meeting held more than ten (10) days after the Planning Commission's decision; and

**WHEREAS**, on the basis of the application and the evidence submitted to the Planning Commission, the Planning Commission made the following findings specified in Section 9-15E-6E of the Lemoore Municipal Code:

1. That the proposed location of the Planned Unit Development is in accordance with the objective of the Zoning Ordinance.
2. That the proposed location of the Planned Unit Development and the conditions under which it would be operated or maintained will not be detrimental to the Public Health, Safety and Welfare or materially injurious to properties or improvements in the vicinity.
3. That the proposed Planned Unit Development will comply with each of the applicable provisions of Title 9 of the Lemoore Municipal Code.



4. That the standards of population density, site area and dimensions, site coverage, yard spaces, height of structures, distance between structures, off-street parking and off-street loading facilities, landscaped areas and street design will produce an environment of stable and desirable character consistent with the objectives of the zoning regulations and will not generate more traffic than the streets in the vicinity can carry without congestion and will not overload utilities.
5. That the different dwellings will compliment each other and will harmonize with existing and proposed land uses in the vicinity (once condition #27 of the following conditions is meet).

**NOW, THEREFORE, BE IT RESOLVED** that the City Council of the City of Lemoore has approved by separated motion to adopt a Mitigated Negative Declaration and does hereby approve the Vesting Tentative Subdivision Map No.2004-05 / Planned Unit Development No.2004-03 / Conditional Use Permit No.2004-08 as applied for by Lennar Fresno, Inc. with the following 36 conditions, and such approval will be valid two (2) years following the effective date of the City Council Ordinance No. 2005-02 for Zone Change (anticipated to be March 31, 2005):

1. In order to try to preserve the Hi Clawson home, the house shall be sold and not demolished. If other ancillary buildings are to be demolished a full pictorial record shall be made of all exterior and interior components and any items of historic value can be retained for the Sarah A. Mooney Museum historic records or other Kings County museums.
2. All arterial and collector street improvements shall be made in conformance to mitigation measures identified in a traffic study, to be paid for by the developer and hired by the City, to insure that the Level of Service does not dip below City standards and the carrying capacity is not exceeded along the roadways with the installation of this project. (Possible mitigation measures are listed in the last page of the environmental impact assessment.) Due to street alignment shifts in 19th Avenue additional right-of-way and/or paving may be needed on the project site as improvements are already in place on the western half of the street.
3. A meandering sidewalk of 10' in width shall be provided along all arterial and collector streets. Bike lane striping will be done on both sides of Liberty Drive from Cinnamon Drive to Hanford-Armona Road where none exists.
4. All standard City improvements must be installed on the northern half of Cinnamon Drive from the proposed Apricot Drive to 19th Avenue (approximately 310') to match the improvements provided from Liberty Drive to Apricot Drive, with the installation costs paid by the developer and the City taking care of the right-of-way acquisition.
5. Adequate paving and a striping plan must be submitted with the improvement drawings to include adequate turn pockets within and adjacent to the project site and transitional striping where needed where lane widths are not consistent as determined by the City Engineer.

6. R-values will need to be identified on the map and all improvement drawings for streets shall include R-values tests in a quantity sufficient to represent all street areas and have structural street section designed by a registered civil engineer.
7. The following streets shall be modified and parcels adjusted as affected by the changes and submitted to the Community Development Department for approval before improvement drawings are started:
  - Shift all streets north of Fallen Leaf Drive northerly to accomodate additional lots to front onto Fallen Leaf Drive, thereby reducing future maintainance problems and reducing some of the lot depths and sizes in Phase I to still conform to City standards.
  - Persimmon Street shall be modified to meet the 60' right-of-way standards if it connects to an arterial or collector street.
  - Both sections of Peachwood Street walk-through cul-de-sacs shall be converted into loop-out streets towards Plum Street, unless an alternative plan acceptable to City staff is proposed.
  - Direct street access from Persimmon Street to Liberty Drive will be closed off and a loop street put in its place between Sheffield and Persimmon Streets, thereby removing the pedestrian walk-throughs in front of Liberty Middle School and vehicular access, unless an alternative plan acceptable to City staff is proposed.

Provide a standard 60' right-of-way road segment stub street through lots 225 and 226 to align with the proposed Bristol Street to allow future access to 19th Avenue and the future elementary school via a walk-through cul-de-sac street.
8. 60' right-of-way streets shall be revised to meet City standards to include 40' of street width curb-to-curb, 5' landscape strip, and a 4.5' sidewalk.
9. Interior streets that are not considered "feeder streets" will utilize the proposed 54' right-of-way and shall be distributed with a 36' curb-to-curb street width and 4½' parkway landscape strips and 4½' sidewalks on both sides of the street. These streets include the proposed Peachwood Street, Orange Street, Alice Drive, Pecan Drive, Sheffield Street, Bristol Street, Wexford Street, Woodbridge Street, and Clawson Circle.
10. Stop signs must be installed at the intersections with arterial and collector streets as well as at the intersection of Clawsen Drive and Plum Street (to be called Avalon Drive) and shall be included in the improvement drawings.
11. The installation of two self-actuating, in-ground flashing crosswalks must be installed to Liberty Middle School near the Persimmon Street alignment and along 19th Avenue north of the future elementary school. The cost for the 19th Avenue crosswalk could be placed in an account with Public Works to install such device when development occurs on Parcel 3 or when the new elementary school opens.
12. The developer shall submit revised street names for the subdivision to comply with the City Street Naming Policy and shall be submitted to the Community Development Department for approval. Street names should follow a theme.
13. Five (5) sets of a revised landscape and irrigation plans and park layout plan shall be submitted to conform to City standards for street trees, buffer areas and include proposed landscaping for the park with the improvement plans. Such plans shall be approved by the Community Development and Parks and Recreation Departments. A very mature oak tree exist next to the Clawson home and shall be retained and three other mature trees on the same site should try to be retained if possible.

14. A 7' high decorative masonry block wall is required along all arterial and collector streets and such design shall be reviewed and approved by the Community Development Department and included in the improvement drawings.
15. A 10' wide public utility easement must be shown on all lots adjacent to public streets and included in the Final Map.
16. A noise and odor easement must be recorded on the property, in a form acceptable to the City Attorney, to acknowledge the presence of nearby industry and the right of the industry to continue to emit such noise and odors as are otherwise allowable by law and to ensure that industry in these areas is not unreasonably hindered by residential users and owners which move nearby at a later date.
17. A Notice and Disclosure Statement must be recorded on the property, in a form acceptable to the City Attorney, which states that neighboring residents should be prepared for the inherent and potential inconveniences and discomforts often associated with normal and usual agricultural activities and operations, and the County will not take any nuisance abatement actions against any normal and usual farming operations must be recorded.
18. The lift pump located at the east corner of 19th Avenue south of Hanford-Armona shall be removed and properly abandoned as required by the Lemoore Canal & Irrigation Company.
19. All existing above ground utilities, except for the 70kv line, shall be undergrounded by the developer. All unused ditches, wells, septic systems, etc. shall be properly abandoned and/or relocated as required by the Public Works Department.
20. A 12" water main shall be installed in Hanford-Armona Road to tie into the water main in 19th Avenue and 10" water main in Liberty Drive. The system shall meet the required minimum fire flow requirements of 1500 G.p.s.i. at 20 p.s.i. and temporary blow-offs will need to be provided at the terminating water mains. Improvement drawings must show existing water lines associated with the development.
21. Sanitary sewer shall be provided in compliance with the requirements of the City of Lemoore and tie into the existing 12" line in Liberty Drive and/or 18" line in Cinnamon Drive. The applicant's engineer shall provide sanitary sewer calculations verifying pipe sizes and slopes and show existing sewer lines associated with the development.
22. Storm drainage shall be provided for the entire tract to comply with the Storm Drain Master Plan and the Kings Mosquito Abatement District requirements as approved by the City Engineer. A storm line must be provided to serve the Covington Place Subdivision on Hanford-Armona Road north of lots 3 and 4 within the subdivision.
23. Fire hydrants shall be spaced 300 feet apart throughout the subdivision as approved by the Lemoore Volunteer Fire Department and shall be included in the improvement drawings.
24. Street lights shall be installed to comply with City Standards for arterial and collector streets around the perimeter of the subdivision. Street lights within the subdivision, shall comply with City Standards for local streets.

25. Improvement drawings must show existing and proposed sanitary sewer, storm drainage, water, street lights, fire hydrants and street infrastructure (including curb, gutter, and parkway style sidewalks) associated with the development. All proposed and existing onsite utilities shall be undergrounded by the developer at their expense. Any utility which may need to be relocated will also be undergrounded. The improvement plans for the subdivision must be approved by the City of Lemoore Engineer and Public Works Departments.
26. The installation of cluster mail box units shall be coordinated with the Lemoore Postmaster and the financial responsibility of the developer.
27. Revised and/or additional elevations and a revised footprint plan shall be submitted to the Community Development Department for Planning Commission review and approval prior to a Final Map being recorded for any phase of development.
28. The subdivision shall request inclusion in the lighting and landscaping maintenance district (LLMD) to maintain the surrounding landscaping, lighting and open space areas. If the City Council does not accept inclusion into an LLMD, a Homeowners Association or other mechanism acceptable to the City Council shall be created to establish responsibility for maintenance of these common areas.
29. *The subdivision shall be built utilizing the recommendations contained in the soils report.*
30. *A digital copy of the final map and improvement plans shall be provided to the City upon prior to Final Map recordation.*
31. *That the developer shall at all times comply with the Fugitive Dust Control Standards of the San Joaquin Valley Unified Air Pollution Control District and shall take complete control of dust during the preparation of the subdivision site and during construction by taking the following measures:*
  - a. *Submit for approval of the Public Works Director a program for the control of dust, which shall include, but not limited to, a watering schedule (frequency and time of day), use of dust control emulsions, and/or other measures necessary for control of dust.*
  - b. *Provide equipment and labor for watering of all exposed or disturbed soil surfaces, including weekends and holidays.*
  - c. *Sweep construction area and adjacent streets of all mud and dust at the end of the workday.*
  - d. *In addition, the developer shall deposit with the City an amount of five thousand dollars (\$5,000) which may be used by the City for dust control measures on this development, should the developer fail to adequately control dust. In case the City incurs costs for dust control in excess of the above amount, the developer shall reimburse the City for this additional amount. Upon acceptance by the City of the subdivision improvements, the deposit sum less any amount expended by the City will be refunded to the subdivider.*

32. That the developer and contractor shall comply with all applicable provisions of the NPDES regulations, and are responsible for all General Permit applications to the Regional Water Quality Control Board. Proof of application shall be provided to the City prior to commencement of construction.
33. That the developer shall submit to the Community Development Department the following documents for processing after approval of the Tentative Subdivision Map.
- a) Five (5) copies of the final subdivision map along with closure calculations, preliminary title report dated within 90 days of submittal, and the final map application fee. The final map shall bear the signature and seal of the licensed land surveyor or registered civil engineer licensed to practice land surveying, preparing the map. If any of these required elements are missing, no attempt will be made to review the submittal.
  - b) Five (5) copies of subdivision improvement plans shall be submitted to the Community Development Department including water, sewer, storm drainage, street lighting, sidewalks, curb, gutter and fire hydrants drawn at a scale of not less than 1"=40' horizontal and 1"=4' vertical to be distributed to all commenting parties. General layout and grading may be shown on 24"x36" plan sheets. Plan and profile sheets shall be provided for curb grades and all proposed underground construction, and shall identify points of crossing. Calculations for pavement sections and any nonstandard facilities shall be provided. Details for all construction not covered by City Standard Specifications and/or Detail Drawings shall be provided. Plans shall be signed and sealed by the civil engineer in responsible charge. No review will be attempted on an incomplete submittal.
  - c) Two (2) copies of the engineer's cost estimates for the proposed improvements showing quantities and unit prices. Unit prices shall conform to the City standard prices, which are available at the Public Works Department.
  - d) That after review of the final map is complete, the applicant's engineer shall submit a letter certifying that monumentation is in place and ready for field inspection. Upon receipt of that letter, staff will inspect the monumentation of the tract, prior to final approval of the map. If monumentation of individual lots is to be delayed until construction, the owner shall post with the City a bond-guaranteeing placement of all required monumentation.
  - e) That prior to submittal of the original tracings of the final map to the City for signature and recordation, the original tracing shall include notarized signatures (in black indelible ink) of all persons having record interest in the area within the boundary of the map, the seal and signature (in indelible ink) of the Registered Civil Engineer/Licensed Land Surveyor preparing the map, and the signature (in black indelible ink) of the Kings County Tax Collector. Use of improper ink for these signatures may cause rejection of the map by the City or the County Recorder's office.
  - f) That after approval of the improvement drawings, the City will maintain possession of the original drawings for the duration of the project. The developer or his representative may obtain copies through a certified blueprinting service (Western Blueprinting or Airport Blueprint) that will retrieve the originals, make the needed copies and return the originals to the City.

- g) That upon completion of the subdivision improvements and their acceptance by the City, the developer's engineer shall prepare drawings of as built improvements and shall submit to the City one reproducible and three blue line copies for the City's records.
34. That all subdivision improvements including water, sewer, storm drainage, curbs, gutters, sidewalks, street lights, fire hydrants and street improvements shall comply with the Public Works Standards of the City unless provided differently in this report as an allowed Planned Unit Development standard and meet the approval of the City Engineer.
35. That the subdivider shall defend, indemnify and hold harmless the City of Lemoore and all of its departments, officers, agents and employees of and from all claims, actions and proceedings of any kind or nature to attack, set aside, void or annul the actions of the Planning Commission and/or City Council in reviewing and approving the map. This condition is imposed pursuant to Government Code Section 66474.9. The City will promptly notify the subdivider of any such claim or action and will fully cooperate with the subdivider in the defense thereof.
36. That in accordance with the finding of the City Council in Resolution 2000-21 and the Quad-Knopf study dated June, 2000, the project will have an impact on the need for new public facilities and improvements in the City. The costs associated with that impact and the connection between the need for new public facilities and the proposed project are set forth in Resolution 2000-21 and the Quad-Knopf study. As a result, the applicant shall be subject to and shall pay these impact fees set forth in Resolution 2000-21.

Passed and adopted at a Regular Meeting of the City Council of the City of Lemoore held on the 15th day of February, 2005, by the following vote:

**AYES:** Andreasen, Martin, Murray, Grego, Buford  
**NOES:** None  
**ABSTAINING:** None  
**ABSENT:** None

**APPROVED:**

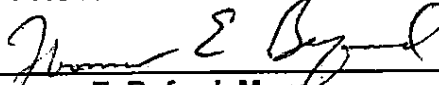
  
Thomas E. Buford, Mayor

**ATTEST:**

  
Nanci C.O. Lima, City Clerk

CERTIFICATE

STATE OF CALIFORNIA )

COUNTY OF KINGS ) ss.  
CITY OF LEMOORE )

I, Nanci C.O. LIMA, City Clerk of the City of Lemoore, do hereby certify the foregoing Resolution of the City Council of the City of Lemoore was duly passed and adopted at a Regular Meeting of the City Council held on February 15, 2005.

DATED: February 17, 2005

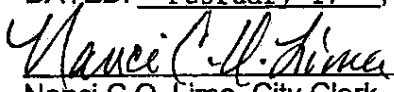
  
\_\_\_\_\_  
Nanci C.O. Lima, City Clerk

Advice 4202-E  
March 14, 2013

Attachment 5:  
Notice of Determination for the Mitigated  
Negative Declaration



NOD 2004-25

**ORIGINAL  
FILED**  
FEB 22 2005  
**GEORGE J. MISNER  
KINGS COUNTY CLERK**

**CITY OF LEMOORE  
NOTICE OF DETERMINATION**

05-038

To:      Office of Planning and Research  
1400 Tenth Street, Room 121  
Sacramento, CA. 95814

From: City of Lemoore  
119 Fox Street  
Lemoore, CA. 93245

  X   County Clerk  
County of Kings  
Government Center  
Hanford, CA. 93230

I declare, under penalty of perjury, that on the date below I posted a copy of this notice in the office of the County Clerk that said notice remained posted for 30 days.  
Date 2-22-05  
GEORGE J MISNER, County Clerk Recorder  
By Resi Alenany Deputy

**SUBJECT**

Filing of Notice of Determination in compliance with Section 21108 or 21152 of the Public Resources Code.

Zone Change, Vesting Tentative Subdivision Map No. 2004-05/Planned Unit Development No.2004-03/Conditional Use Permit No.2004-08 for Tract 821

**Project Title**

<u>Not Applicable</u>	<u>Holly Smyth</u>	<u>(559) 924-6740</u>
<b>State Clearing House Number</b>	<b>Lead Agency</b>	<b>Area code/Telephone No.</b>
	<b>Contact Person</b>	

The subject tract is north of Cinnamon Drive, south of Hanford-Armona Road, east of 19<sup>th</sup> Avenue and west of Liberty Drive. in Kings County.

**Project Location** (include county)

**Project Description:**

Zone Change No.2004-02 and Vesting Tentative Subdivision Map No.2004-05/Planned Unit Development No.2004-03/Conditional Use Permit No.2004-08, application by Lennar Fresno, Inc. to remove the existing structures and subdivide Tract No.821, consisting of approximately 68 acres into 238 single family lots, in two phases. The subject tract is north of Cinnamon Drive, south of Hanford-Armona Road, east of 19<sup>th</sup> Avenue and west of Liberty Drive. Ingress/egress to the development is from Hanford-Armona Road, 19<sup>th</sup> Avenue, Cinnamon Drive and Liberty Drive. The minimum lot size is proposed to be 7,000 sq. ft. and the average lot size is to be 8,479 sq. ft. The site is currently zoned UR (Urban Reserve) in accordance to the provisions of the Lemoore Municipal Code. The site is described as Assessor Parcel No.021-620-001.

The Zone Change is proposed to change the zone classification of the above described 68 acre site from UR(Urban Reserve) to R-1-7PUD(Single Family Residential, Planned Unit Development).

This to advise that the Lemoore City Council adopted the above described Zone Change, Vesting Tentative Subdivision Map/Planned Unit Development/Conditional Use Permit on February 15, 2005 and has made the following determinations regarding the above described project:

1. The project {  will  will not } have a significant effect on the environment.
2.  An Environmental Impact Report was prepared for this project pursuant to the provisions of CEQA.  
 A Negative Declaration was prepared for this project pursuant to the provisions of CEQA.
3. Mitigation measures {  were  were not } made a condition of the approval of the project.
4. A statement of Overriding Considerations {  was  was not } adopted for this project.
5. Findings {  were  were not } made pursuant to the provisions of CEQA.

This is to certify that the record of project approval is available to the General Public at the City of Lemoore, Community Development Dept., 210 Fox St. in Lemoore, California, 93245

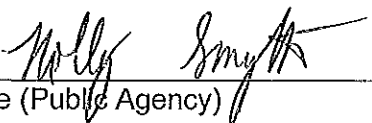
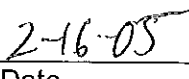
		
Signature (Public Agency)	Title	Date

Date received for filing at OPR: Not applicable

ND 2004-25

CITY OF LEMOORE

NEGATIVE DECLARATION NO.2004-25

**Project: Zone Change No.2004-02; Vesting Tentative Subdivision Map No.2004-05/Planned Unit Development No.2004-03/Conditional Use Permit No.2004-08**

Description

Zone Change No.2004-02 and Vesting Tentative Subdivision Map No.2004-05/Planned Unit Development No.2004-03/Conditional Use Permit No.2004-08, application by Lennar Fresno, Inc. to remove the existing structures and subdivide Tract No.821, consisting of approximately 68 acres into 238 single family lots, in two phases. The subject tract is north of Cinnamon Drive, south of Hanford-Armona Road, east of 19<sup>th</sup> Avenue and west of Liberty Drive. Ingress/egress to the development is from Hanford-Armona Road, 19<sup>th</sup> Avenue, Cinnamon Drive and Liberty Drive. The minimum lot size is proposed to be 7,000 sq. ft. and the average lot size is to be 8,479 sq. ft. The site is currently zoned UR (Urban Reserve) in accordance to the provisions of the Lemoore Municipal Code. The site is described as Assessor Parcel No.021-620-001.

The Zone Change is proposed to change the zone classification of the above described 68 acre site from UR(Urban Reserve) to R-1-7PUD(Single Family Residential, Planned Unit Development).

Finding:

The proposed project is in conformance with all Codes, Ordinances and regulations of the City of Lemoore and will not have a significant effect on the environment.

Preparation of Study

The Initial Study of this proposal was undertaken by the Staff of the City of Lemoore. Copies may be obtained from the Community Development Office of the City of Lemoore, 406 "B" Street, Lemoore, California 93245.

CALIFORNIA DEPARTMENT OF FISH AND GAME

CERTIFICATE OF FEE EXEMPTION

COUNTY OF KINGS

De Minimis Impact Finding

**Project Title/Location:**

Zone Change No.2004-02 and Vesting Tentative Subdivision Map No.2004-05/Planned Unit Development No.2004-03/Conditional Use Permit No.2004-08, application by Lennar Fresno, Inc. to remove the existing structures and subdivide Tract No.821. The subject tract is north of Cinnamon Drive, south of Hanford-Armona Road, east of 19<sup>th</sup> Avenue and west of Liberty Drive. The site is described as Assessor Parcel No.021-620-001.

The Zone Change is proposed to change the zone classification of the above described 68 acre site from UR(Urban Reserve) to R-1-7PUD(Single Family Residential, Planned Unit Development).

**Project Description:**

Application by Lennar Fresno, Inc. to remove the existing structures and subdivide Tract No.821, consisting of approximately 68 acres into 238 single family lots, in two phases. Ingress/egress to the development is from Hanford-Armona Road, 19<sup>th</sup> Avenue, Cinnamon Drive and Liberty Drive. The minimum lot size is proposed to be 7,000 sq. ft. and the average lot size is to be 8,479 sq. ft. The site is currently zoned UR (Urban Reserve) in accordance to the provisions of the Lemoore Municipal Cod

The Zone Change is proposed to change the zone classification of the above described 75 acre site from UR(Urban Reserve) to R-1-7PUD(Single Family Residential, Planned Unit Development).

**Findings of Exemption (attach as necessary):**

The lead agency (as defined by Section 21067 of the Public Resources Code) finds that, considering the record as a whole, the project involves no potential for adverse effect, either individually or cumulatively on wildlife (as defined by Section 711.2 of the Fish and Game code).

**Certification:**

I hereby certify that the public agency has made the above finding and that the project will not individually, or cumulatively have an adverse effect on wildlife resources, as defined in Section 711.2 of the Fish and Game Code.

Molly Smyth  
(Chief Planning Official)

Title: Chief Planner

Lead Agency: City of Lemoore

Date: 2-16-05

EIA 2004-25

CITY OF LEMOORE

ENVIRONMENTAL IMPACT ASSESSMENT NO.2004-25

Title: Zone Change No.2004-02; Vesting Tentative Subdivision Map No.2004-05/Planned Unit Development No.2004-03/Conditional Use Permit No.2004-08

**Location and Description**

Zone Change No.2004-02 and Vesting Tentative Subdivision Map No.2004-05/Planned Unit Development No.2004-03/Conditional Use Permit No.2004-08, application by Lennar Fresno, Inc. to remove the existing structures and subdivide Tract No.821, consisting of approximately 68 acres into 238 single family lots, in two phases. The subject tract is north of Cinnamon Drive, south of Hanford-Armona Road, east of 19<sup>th</sup> Avenue and west of Liberty Drive. Ingress/egress to the development is from Hanford-Armona Road, 19<sup>th</sup> Avenue, Cinnamon Drive and Liberty Drive. The minimum lot size is proposed to be 7,000 sq. ft. and the average lot size is to be 8,479 sq. ft. The site is currently zoned UR (Urban Reserve) in accordance to the provisions of the Lemoore Municipal Code. The site is described as Assessor Parcel No.021-620-001.

The Zone Change is proposed to change the zone classification of the above described 68 acre site from UR(Urban Reserve) to R-1-7PUD(Single Family Residential, Planned Unit Development).

**Staff Determination**

The City's staff, having undertaken and completed an Initial Study of the project in accordance with City and State Guidelines for implementing the California Environmental Quality Act, finds as follows:

The proposed project **COULD NOT** have a significant effect on the environment if certain mitigation measures are added to the project and a **MITIGATED NEGATIVE DECLARATION** should be prepared.

DATED: 2-16-04

  
\_\_\_\_\_  
Holly Smyth, Chief Planner

**PG&E Gas and Electric  
Advice Filing List  
General Order 96-B, Section IV**

1st Light Energy	Douglass & Liddell	North America Power Partners
AT&T	Downey & Brand	Occidental Energy Marketing, Inc.
Alcantar & Kahl LLP	Ellison Schneider & Harris LLP	OnGrid Solar
Anderson & Poole	G. A. Krause & Assoc.	Pacific Gas and Electric Company
BART	GenOn Energy Inc.	Praxair
Barkovich & Yap, Inc.	GenOn Energy, Inc.	Regulatory & Cogeneration Service, Inc.
Bartle Wells Associates	Goodin, MacBride, Squeri, Schlotz & Ritchie	SCD Energy Solutions
Bear Valley Electric Service	Green Power Institute	SCE
Braun Blaising McLaughlin, P.C.	Hanna & Morton	SPURR
CENERGY POWER	In House Energy	San Francisco Public Utilities Commission
California Cotton Ginners & Growers Assn	International Power Technology	Seattle City Light
California Energy Commission	Intestate Gas Services, Inc.	Sempra Utilities
California Public Utilities Commission	Kelly Group	SoCalGas
Calpine	Lawrence Berkeley National Lab	Southern California Edison Company
Casner, Steve	Linde	Sun Light & Power
Center for Biological Diversity	Los Angeles Dept of Water & Power	Sunshine Design
City of Palo Alto	MAC Lighting Consulting	Tecogen, Inc.
City of San Jose	MRW & Associates	Tiger Natural Gas, Inc.
Clean Power	Manatt Phelps Phillips	TransCanada
Coast Economic Consulting	Marin Energy Authority	Utility Cost Management
Commercial Energy	McKenna Long & Aldridge LLP	Utility Power Solutions
Consumer Federation of California	McKenzie & Associates	Utility Specialists
Crossborder Energy	Modesto Irrigation District	Verizon
Davis Wright Tremaine LLP	Morgan Stanley	Water and Energy Consulting
Day Carter Murphy	NLine Energy, Inc.	Wellhead Electric Company
Defense Energy Support Center	NRG Solar	Western Manufactured Housing Communities Association (WMA)
Dept of General Services	Nexant, Inc.	