



**PG&E ELECTRIC SERVICE TO ANTENNA AND COMMUNICATION 094678**  
**EQUIPMENT ON MUNICIPALITY OWNED STEEL STREETLIGHT POLES**

**Asset Type:** Electric Distribution *D.W. Jantz* **Function:** Design, Estimating, and Planning

**Issued by:** Daniel Jantz (DWJ7) **Date:** 03-25-22

**Rev. #00:** This new document replaces bulletin TD-027911-B004, Rev. #03. For a description of the changes, see Page 14.

**Purpose and Scope**

This document provides requirements for interconnecting, 3rd party telecommunication equipment installed on Governmental Agency (Municipality) owned steel streetlight poles, to the PG&E electric distribution system. These interconnections are allowed only for Municipality-owned steel streetlight poles that are on a LS-2 rate schedule.

With PGE providing power, the single Municipality-owned service wire supplies both the metered 3rd- party communication and antenna equipment as well as the unmetered streetlights installed on the Municipality owned steel pole.

References	Location	Document
<a href="#">Installation Details for Service to Pole-Mounted Communication Equipment</a> .....	<a href="#">OH: Services/Greenbook</a> .....	<a href="#">027911</a>
<a href="#">SmartPole Meter for Service to Pole-Mounted Communication Equipment</a> .....	<a href="#">UG-1: Services/Greenbook</a> .....	<a href="#">094675</a>
<a href="#">PG&amp;E Metered Electric Service to Antenna and Communication Equipment on Company Owned Steel Streetlight Poles</a> .....	<a href="#">UG-1: Services/Greenbook</a> .....	<a href="#">094677</a>
<a href="#">PG&amp;E Metered Electric Service to Antenna and Communication Equipment on Non-PG&amp;E Telecommunication Owned Poles</a> .....	<a href="#">UG-1/OH: Services, Greenbook</a> .....	<a href="#">094679</a>

**General Information**

1. A PG&E Absolving Service Agreement is required to be signed when Municipality owned services, supplying power to non-PG&E owned steel streetlight poles with communication and antenna equipment, are interconnected to the PG&E distribution system. Contact the PG&E Service Planning office for an explanation of an Absolving Service Agreement. If needed, PG&E personnel can contact the Tariff Interpretation or Law departments for guidance.
2. The antenna, communication equipment, and streetlight must be powered from the same municipality owned service. A second or separate municipality owned service is not allowed.
3. The local Authority Having Jurisdiction (AHJ) of inspections for the city or county must provide approval of final inspection and meter release before PG&E will install a meter and energize the municipalities electric service.
4. A PG&E inspector or Trouble Man (T-Man) must inspect the installation to verify the requirements in this document have been met.
5. PG&E vehicle (bucket truck) access up to and around the pole is required **at all times**. This includes a road which allows the PG&E vehicle to drive up next to the pole and have, but not limited to, an adequate area to back up, maneuver, exit, and extend its outriggers. This vehicle drive-up access is required for the installation, maintenance, and troubleshooting of the PG&E meter.
6. All materials, except the PG&E meter, must be furnished and installed by the municipality. This includes the meter socket and disconnect switch combination enclosure.
7. For service connections to steel poles that are **not** on a LS-2 rate, or if the requirements in this document cannot be met, then the PG&E approved method of providing service to a pad- mounted metering pedestal must be used.

### Underground Service

8. Install a 2–wire (1–hot, 1–neutral) 120 volt single–phase service from the PG&E specified splice box to the pole or from a municipality owned splice box to the pole, if the box is part of a municipality owned street light distribution system. A 2–wire 120 volt single–phase service is the only type of service allowed to power the SmartPole meter along with the municipality and 3rd party equipment. The municipality service wire must be sized as needed to accommodate all metered and un-metered loads.

Note: In very limited locations if an existing PG&E 2–wire single–phase 240 volt secondary system is available the SmartPole meter may be connected. These locations are not common.

9. **CAUTION:** Do not install a 3–wire 1–phase 120/240 volt service as this is an incorrect application for powering both the SmartPole metering and streetlight with one service.

### SmartPole Metering

10. A PG&E SmartPole Meter and enclosure are required for these installations. Refer to PG&E [Document 094675](#) listed on Page 1, for specific requirements.

Note: Other designs for the placement of the metering equipment not in compliance with the requirements described in this document are **not** being accepted.

11. The customer load must not exceed 16 amps for non–transformer rated SmartPole meters.
12. The customer load must not exceed 68 amps for transformer rated SmartPole meters.
13. The SmartPole meter must be mounted on the same pole as the service, antenna, and communication equipment. **Remote metering is not allowed.**
14. Do **not** install the SmartPole Meter in the shroud at the top of the pole for new or upgraded installations.
15. The meter and enclosure must be installed on the pole at a minimum of 7 feet to a maximum of 8 feet above grade, as measured from the bottom of the enclosure, and not exposed to vehicular traffic.
16. PG&E Meters must **not** be installed on poles that are in traffic medians or traffic islands where vehicle thoroughfares are on more than one side of the pole. A different pole must be selected for the meter, service, antenna, and communication equipment.
17. The metering provision contained herein is an exception to the Greenbook requirement and is designed primarily for antenna and communication type equipment requiring metering.

### Disconnect Switch

18. A lockable disconnect switch must be installed and meet all of the following requirements below. This may include the Meter & Disconnect combination enclosure shown in Figure 7.
19. Refer to [Document 094675](#) for installation requirements.
20. The disconnect switch must de–energize all customer equipment (ac and dc) on the pole, including antennas, power supplies, radios, as well as any types of backup power sources.
21. The disconnect switch must be readily accessible at all times. The switch will be used as part of the normal or emergency shutdown protocols required in California Public Utility Commission (CPUC) General Order 95, Rule 9
22. Signage must be attached to the switch identifying what equipment it will de–energize.
23. The switch must not de–energize (turn off) the streetlight(s) or the PG&E Smart Meter. See the Single Line Drawing in Figure 8.
24. If installing an individual disconnect switch, instead of the meter & disconnect combination enclosure, it must be attached externally on the pole less than 10 feet above grade and more than 4 feet above grade, as measured to the bottom of the switch enclosure.

Note: The local authority having jurisdiction of inspection may have minimum and maximum height requirements that must also comply besides the PG&E requirements.

25. If using the combination meter and disconnect switch enclosure (Figure 7) the maximum height is 8 feet above grade and the minimum height is 7 feet above grade, as measured to the bottom of the switch enclosure.

## PG&E Electric Service to Antenna and Communication Equipment on Municipality Owned Steel Streetlight Poles

---

26. Provisions for locking the disconnect switch in the off position are required. The locking provisions must accept a PG&E pad-lock with a 5/16" Shaft.
27. The switch may **not** be installed inside the pole (except inside the pedestal), in a subsurface enclosure, or in a remote location away from the pole.
28. The disconnect switch may be located inside an equipment pedestal, installed around the base of the pole, (see Figures 2 through 5) if all of the specific requirements below are met.
  - A. A permanent and dedicated side hinged access door with locking provisions dedicated only for a PG&E pad-lock (5/16" Shaft) must be provided to allow easy access to the disconnect switch.
  - B. This disconnect switch access door can be part of a larger maintenance door if needed.
  - C. The disconnect switch should be installed towards the upper half of the pedestal not less than 18" above grade, as measured to the top of the switch.
  - D. Lock boxes, shared keys, or other locking methods are **not** acceptable.

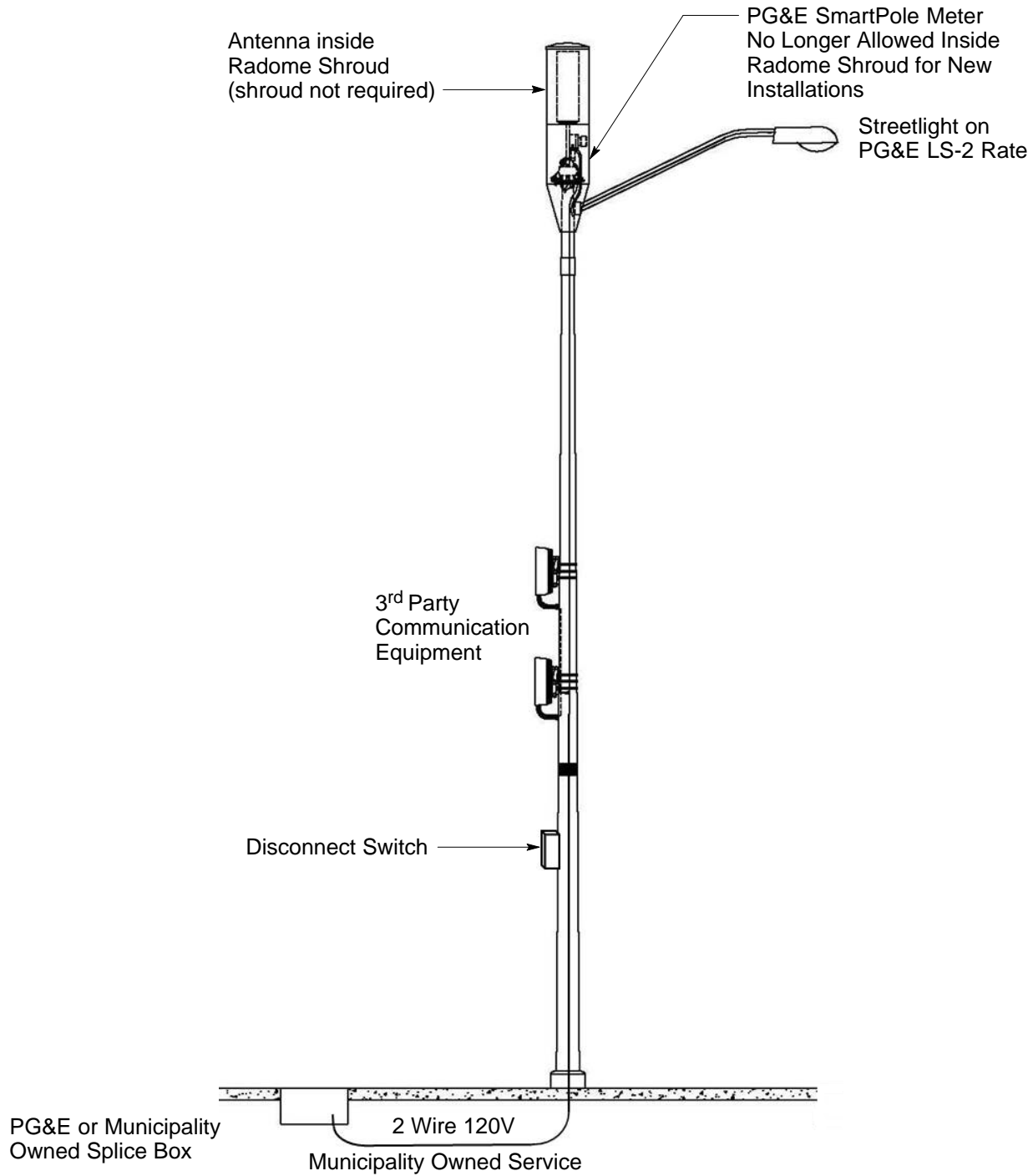
### Signage

29. Poles must have signage that meet FCC guidelines for the antennas and communication equipment emitting RF transmission. Sites must be signed according to FCC guidelines.
30. Antennas and communication equipment installed on PG&E poles must have an ownership label with a contact number and site identification information. Poles shall be marked for each equipment installation. The sign shall contain the following information and placement.
  - A. Name / identification of the antenna operator
  - B. A 24-hour contact number of antenna operator for emergency notification or other information
  - C. Unique identifier of the antenna installation
  - D. Indication that the antennas RF output is in compliance with the FCC General Population (G.P.) uncontrolled exposure limits or if the antenna exceeds those limits indication of the minimum approach distance.
  - E. Located above the SmartPole Meter and not greater than 15 feet above grade.

### Overhead Service

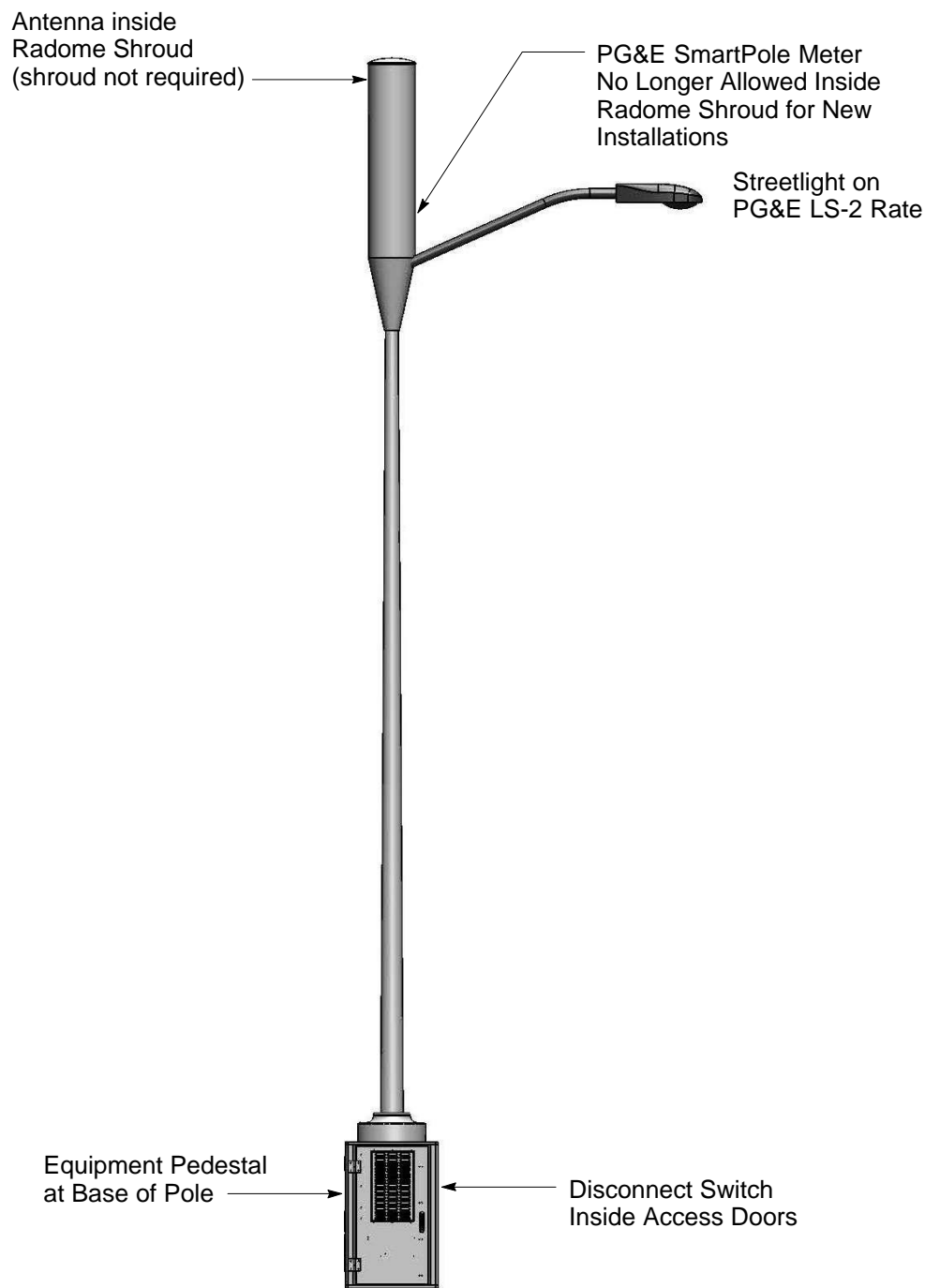
31. See overhead service Figure 8 and Figure 9 on pages 9 and 10.
32. The PG&E overhead service must only terminate at or be attached to streetlight poles with or without an antenna installed on it. The PG&E service must not be attached to poles that do not receive service.
33. A PG&E approved pole band (material code **M188205**) attachment must be permanently installed on the pole by the applicant. For overhead services that dead-end at the pole install a part 1 spool and clevis-type insulator (material code **M315002**) to the pole band for the PG&E service to attach to. For tangent overhead services that continue on to serve another streetlight pole install a part 8 spool and clevis-type insulator (material code **M315034**) to the pole band.
34. Applicant cables must extend a minimum of 36 inches from the pole. This will allow PG&E to create a drip loop when connecting the service cables.
35. The following clearances must be shown and described on drawings submitted to PG&E.
  - A. The vertical clearance, above grade, of the overhead electric service at the pole.
  - B. The vertical clearance, above grade, of the overhead electric service above any thoroughfares and walkable areas. Refer to [4.4.4. Vertical Clearance on Nonresidential Property](#).
  - C. The vertical clearances to all equipment attached on the pole that are above and below the PG&E overhead electric service.
  - D. Radial clearances from the overhead electric service to any structure, pole, and/or equipment along the path of the service wire from pole to pole. Identify and label the type of structure or equipment, if any.

# PG&E Electric Service to Antenna and Communication Equipment on Municipality Owned Steel Streetlight Poles

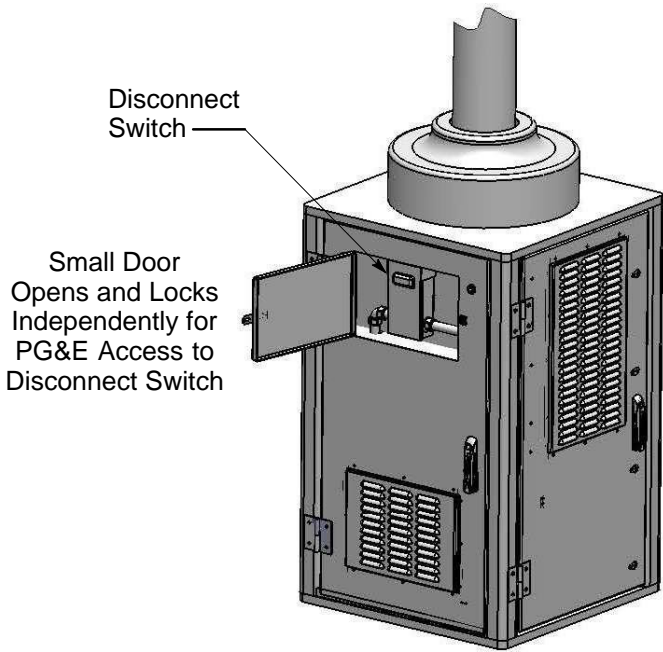


**Figure 1**  
**Underground Service – Municipality Owned (Non-PG&E) Steel Streetlight Pole with Antenna and Communication Equipment**

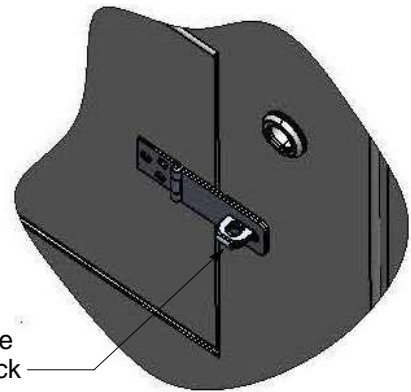
**PG&E Electric Service to Antenna and Communication  
Equipment on Municipality Owned Steel Streetlight Poles**



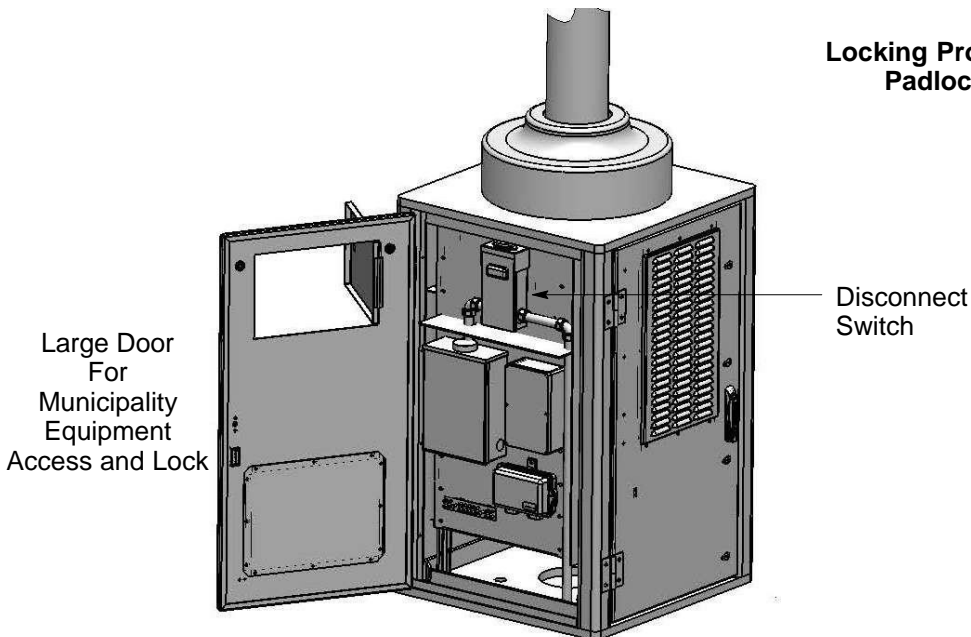
**Figure 2**  
**Underground Service - Municipality Owned (Non-PG&E)**  
**Steel Streetlight Pole with Antenna, Communication**  
**Equipment, and with Equipment Pedestal at Base**



**Figure 3**  
Equipment Pedestal Base with Disconnect  
Switch Inside Small Access Door

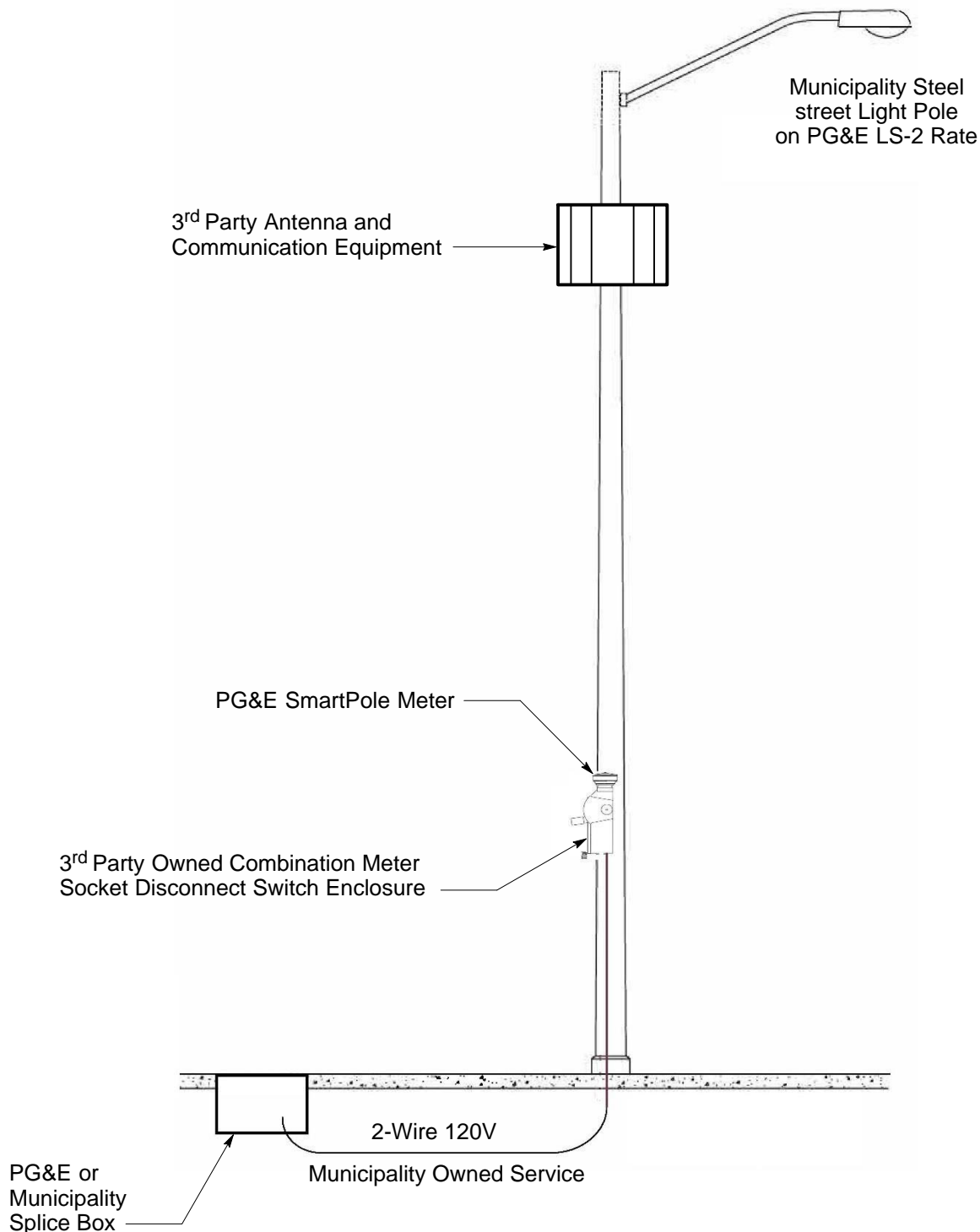


**Figure 4**  
Locking Provisions Dedicated for PG&E  
Padlock on Small Access Door



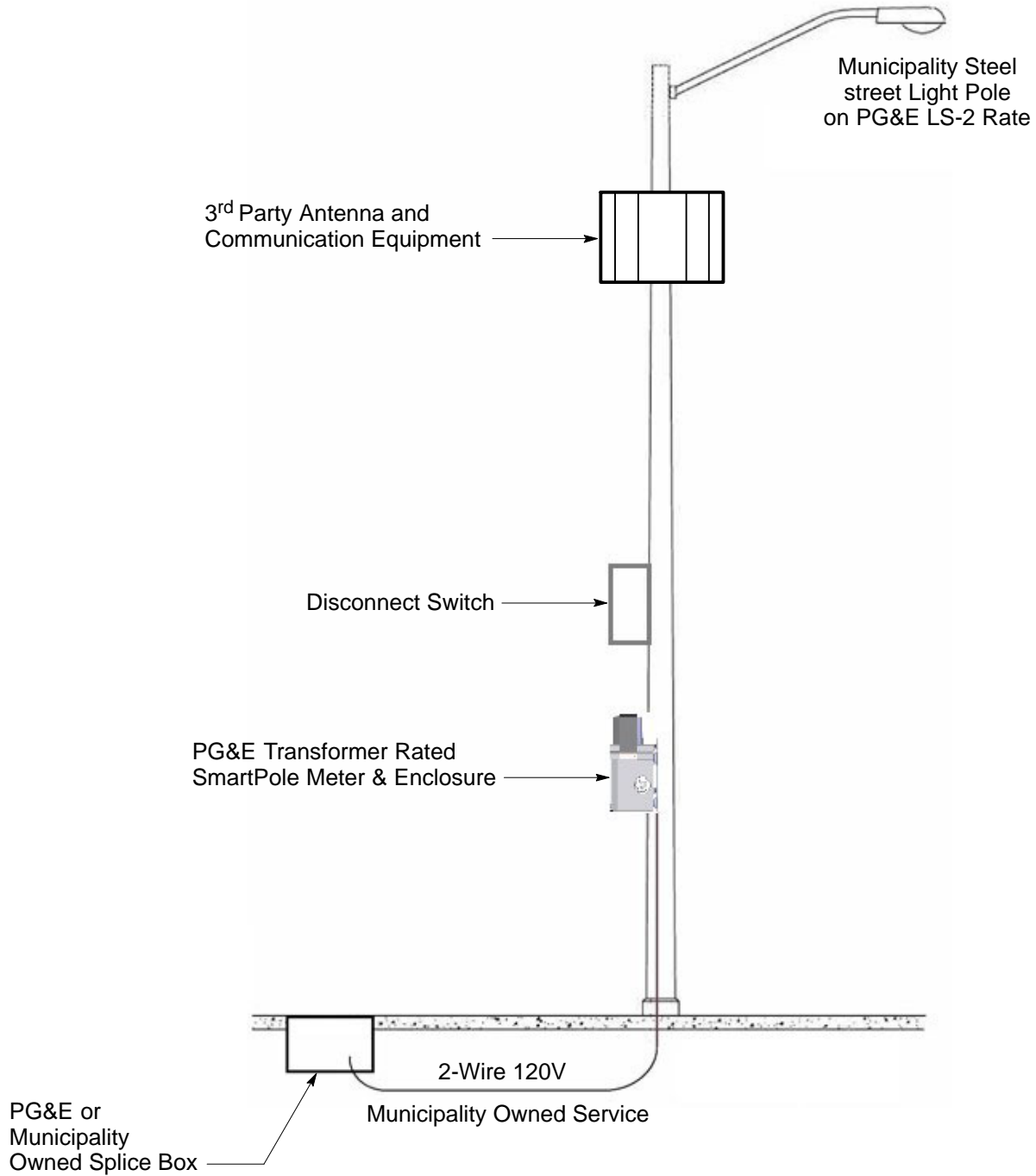
**Figure 5**  
Equipment Pedestal Base With  
Large and Small Access Doors

# PG&E Electric Service to Antenna and Communication Equipment on Municipality Owned Steel Streetlight Poles



**Figure 6**  
**Underground Service – Municipality Owned (Non-PG&E) Steel**  
**Streetlight Pole, Meter Disconnect Switch Combination Enclosure**  
**and Antenna and Communication Equipment**

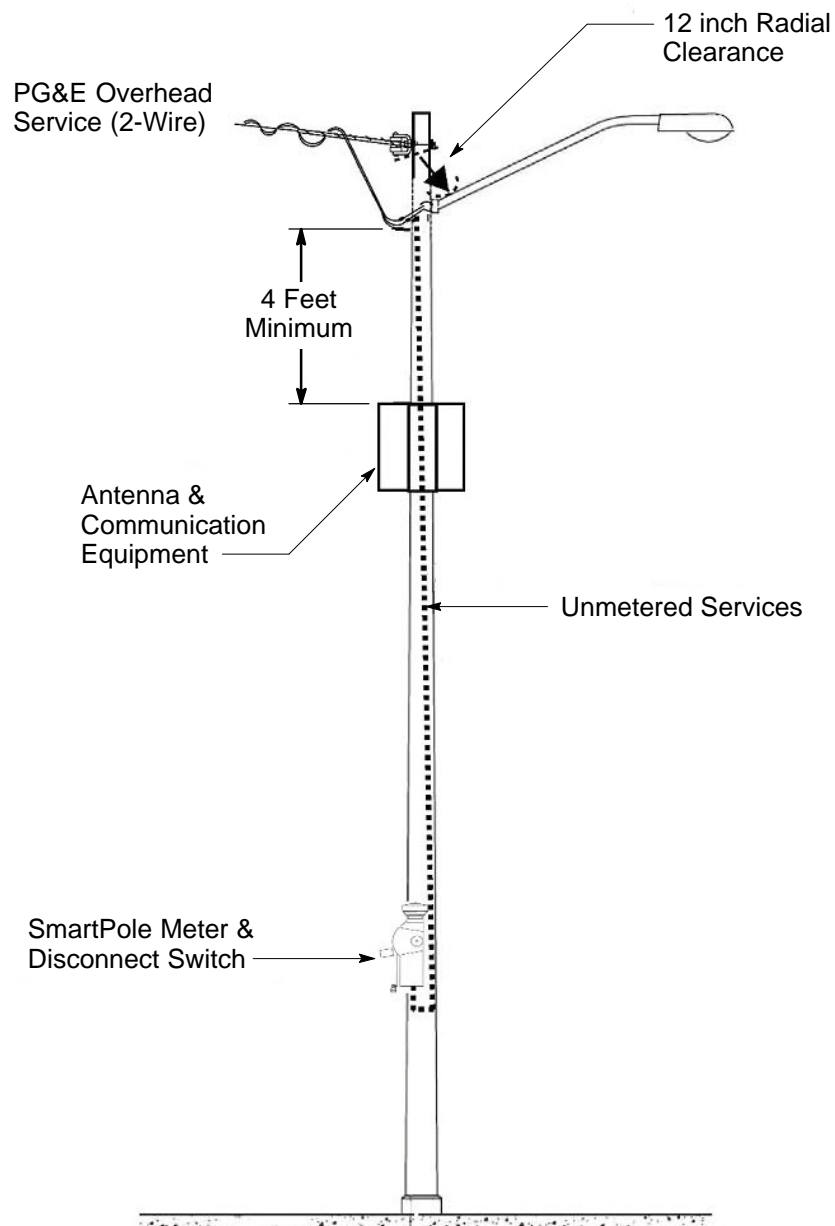
# PG&E Electric Service to Antenna and Communication Equipment on Municipality Owned Steel Streetlight Poles



**Figure 7**  
**Underground Service – Municipality Owned (Non-PG&E) Steel Streetlight Pole, with 100A Meter Enclosure, Disconnect Switch Enclosure and Antenna and Communication Equipment**

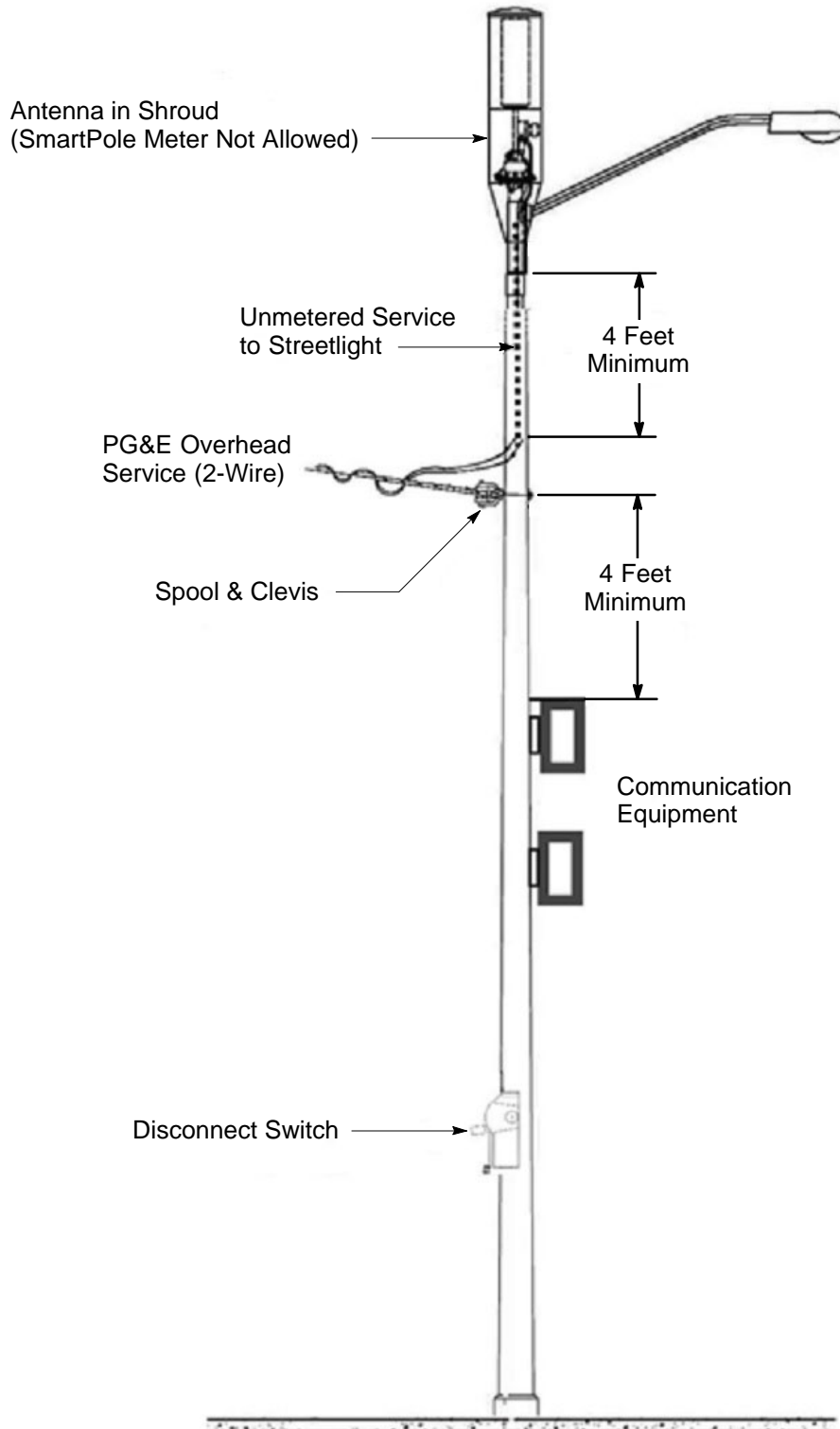


# PG&E Electric Service to Antenna and Communication Equipment on Municipality Owned Steel Streetlight Poles



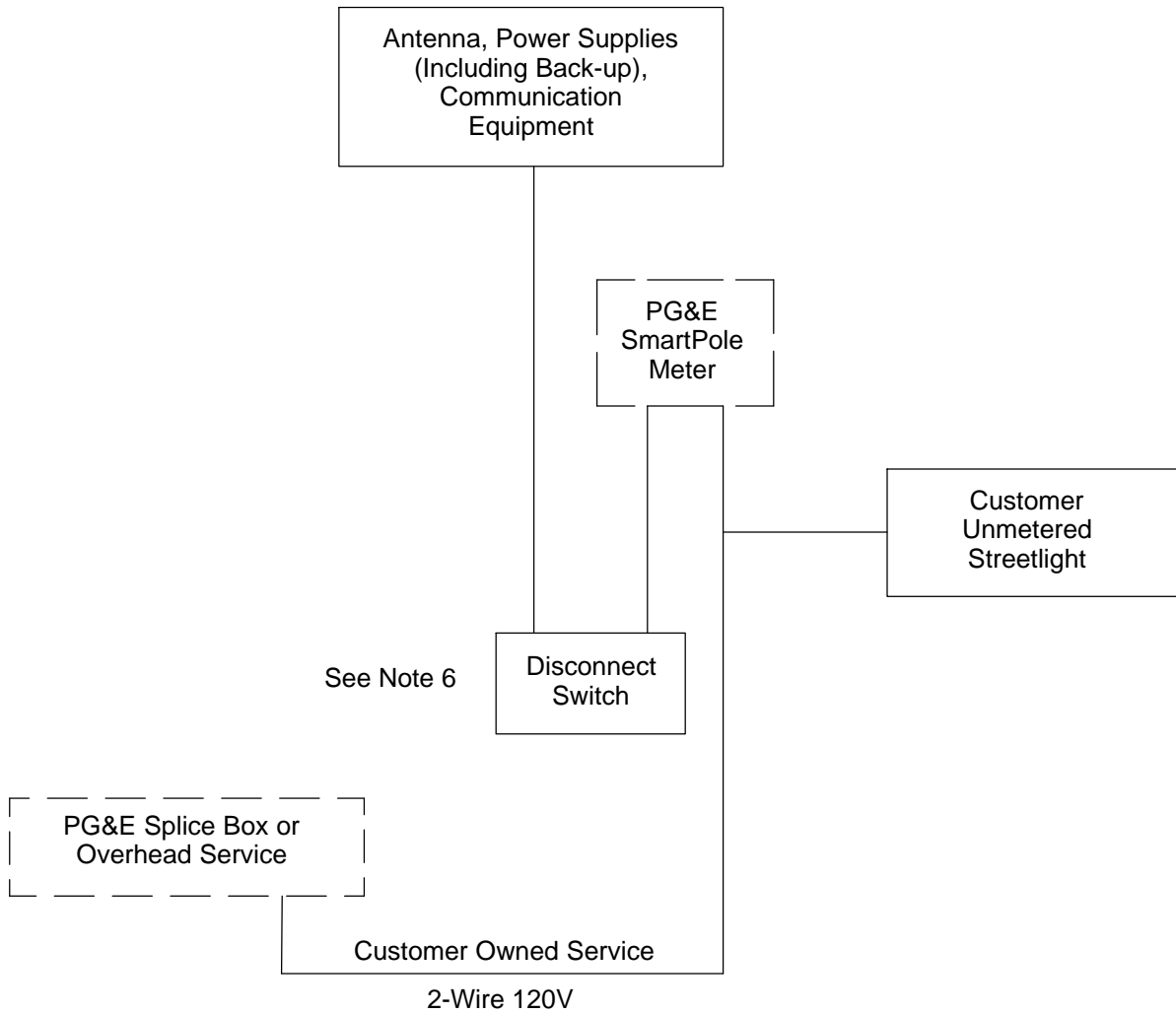
**Figure 8**  
**Overhead Service – Municipality Owned (Non-PG&E)**  
**Steel Streetlight Pole with Antenna and Communication Equipment**

### PG&E Electric Service to Antenna and Communication Equipment on Municipality Owned Steel Streetlight Poles



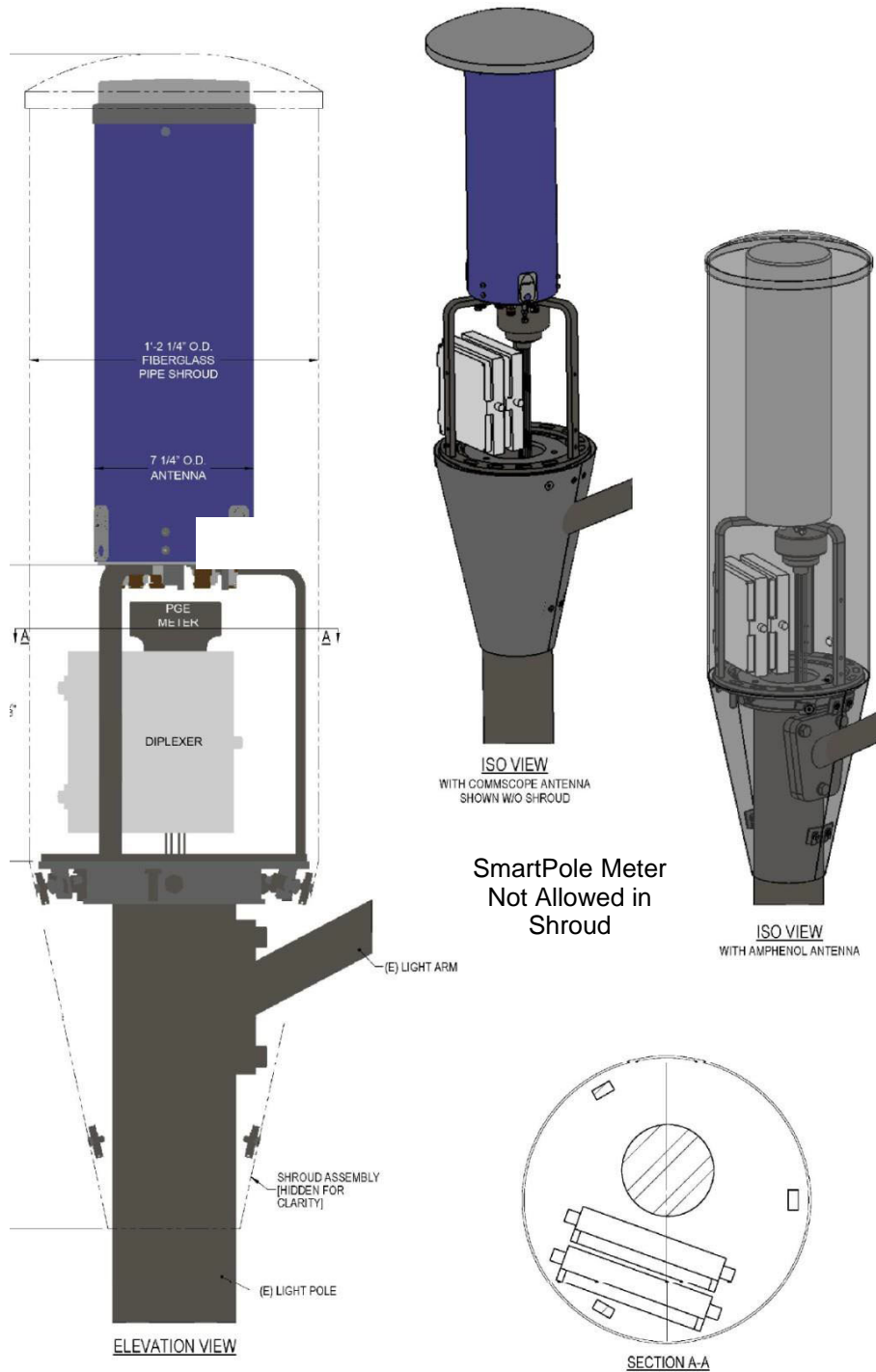
**Figure 9**  
**Overhead Service – Municipality Owned (Non-PG&E) Steel Streetlight Pole with Antenna and Meter in a Shroud**

**PG&E Electric Service to Antenna and Communication  
Equipment on Municipality Owned Steel Streetlight Poles**



**Figure 10  
Single Line Drawing**

# PG&E Electric Service to Antenna and Communication Equipment on Municipality Owned Steel Streetlight Poles



**Figure 11**  
**Radome Shroud Pole Top Detail**

## PG&E Electric Service to Antenna and Communication Equipment on Municipality Owned Steel Streetlight Poles

### NON EMERGENCY NODE SITE POWER SHUT DOWN PROCEDURES

1. FOR NON EMERGENCY/SCHEDULED POWER SHUT DOWN
  - CALL <INSERT NAME OF COMMUNICATION COMPANY AND PROVIDE PHONE NUMBER>
  - 24 HRS PRIOR TO SCHEDULED POWER SHUT OFF PROVIDE THE FOLLOWING INFORMATION:
    - SITE NUMBER IDENTIFIED ON SITE NUMBERING STICKER
    - YOUR NAME AND REASON FOR POWER SHUTOFF
    - PROVIDE DURATION OF OUTAGE
  - PULL DISCONNECT HANDLE TO "OFF" POSITION
  - POWER SHUT OFF VERIFICATION WITH APPROVED PG&E PROCEDURES
  - NOTIFY <INSERT NAME OF COMMUNICATION COMPANY> UPON COMPLETION OF WORK
  - RESTORE POWER BY PLACING POWER DISCONNECT HANDLE IN THE "ON" POSITION
  - REINSTALL LOCK ON POWER HANDLE
2. EMERGENCY POWER SHUT OFF
  - CALL <INSERT NAME OF COMMUNICATION COMPANY AND PROVIDE PHONE NUMBER>
  - PROVIDE THE FOLLOWING INFORMATION:
    - SITE NUMBER IDENTIFIED ON SITE NUMBERING STICKER
    - YOUR NAME AND REASON FOR POWER SHUTOFF
    - PROVIDE DURATION OF OUTAGE
  - PULL DISCONNECT HANDLE TO "OFF" POSITION
  - POWER SHUT OFF VERIFICATION WITH APPROVED PG&E PROCEDURES
  - NOTIFY <INSERT NAME OF COMMUNICATION COMPANY> UPON COMPLETION OF WORK
  - RESTORE POWER BY PLACING POWER DISCONNECT HANDLE IN THE "ON" POSITION
  - REINSTALL LOCK ON POWER HANDLE

Figure 12  
Shut Down Procedure Sign

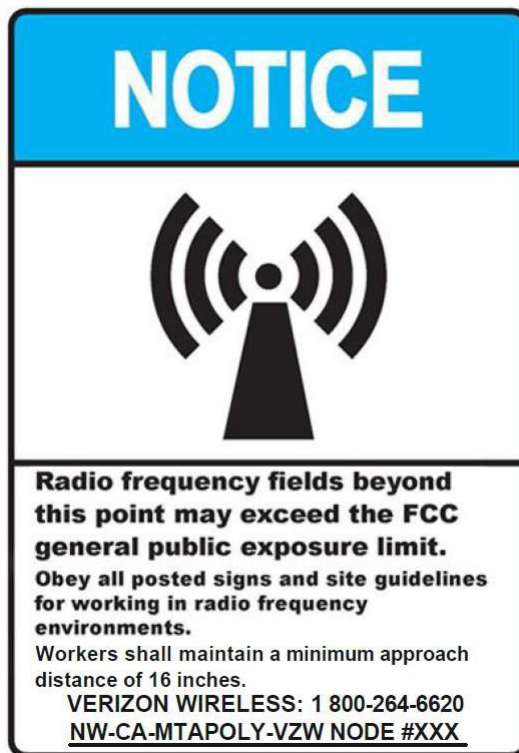


Figure 13  
Sample RF Sign

**Revision Notes.**

Revision 00 has the following changes:

1. Converted Bulletin TD-027911-B004 to this new numbered engineering document.
2. Updated requirements throughout.