



**REQUIREMENTS FOR BUS DUCT ENTRANCE TERMINATION UNIT 063929  
FOR USE WITH PAD-MOUNTED TRANSFORMERS**

<b>Asset Type:</b> Electric Distribution	<b>Function:</b> Design and Construction
<b>Issued By:</b> Lisseth Villareal (LDV2)	<b>Date:</b> 10-29-19
<b>Rev. #12:</b> This document replaces PG&E Document 063929, Rev. #11. For a description of the changes, see Page 10.	

**This document is also included in the following manual:**

- [Electric and Gas Service Requirements Manual](#) (Greenbook)

**Purpose and Scope**

This document provides the tools, ordering instructions, and the necessary manufacturing specifications and details for the fabrication and assembly of bus duct entrance terminations.

The function of the entrance box is to:

- Provide a means for connecting the customer’s bus duct to a pad-mounted transformer.
- Permit a future, larger transformer to be installed without disturbing the existing bus duct installation.
- Reduce the shutdown time for transformer replacement. The entrance box is furnished with two removable sections to permit access to the bus duct extension connections. PG&E will supply and install the entrance box.

**General Information**

1. The “Bus Duct Entrance Termination Unit” is used to provide transition from a customer-provided service entrance bus duct to the low-voltage service compartment of a PG&E, pad-mounted transformer, for services of 3,000 to 4,000 amps.
2. Construction
  - A. The unit’s construction design shown in this document must comply with the Western Underground Committee’s Guide 2.13, latest revision, for tamper-resistant, pad-mounted, equipment enclosures.
  - B. Each top and side cover must latch and securely self-lock at a minimum of three points, when the unit is assembled. All sharp external corners, edges, and joints must be smoothed to prevent injury or damage to clothing.
  - C. The edges, seams, and joints must be made and formed to provide a close-fitting mating surface. Exposed welding on the outside surface of the unit(s) must be a continuous bead, machined and ground flush.
  - D. All metal work must be cleaned free of dirt, oils, and rust, and immediately painted, both inside and outside, with one coat of suitable, rust-inhibiting primer, approximately 1.5 mils thick when dry.
  - E. The interior and exterior of the housing must be finished with one or more coats of Green Munsel, No. 7gy, 3.29/1.5 paint. The total dry film thickness must not be less than 2 mils (the total paint thickness, including primer, not less than 3.5 mils when dry).
  - F. Approximately a half pint of “touch-up” paint (preferably in an aerosol spray can) must be included and shipped with each unit (attached inside the unit to the cable support block).
3. Methods of Serving Large Commercial Customers
  - A. Main Service Rating 201 Through 2,500 Amps: The approved method is by underground cable in customer-installed conduit for cable distance 50 feet or less (refer to [Document 063928](#) for details).
  - B. Main Service Rating 3,000 Through 4,000 Amps: The approved method is a PG&E-owned and installed bus duct entrance box attaching to customer-owned and installed bus duct that is a minimum of 36” long.
4. Note: Bus ducts must only be connected to pad-mounted transformers with a minimum 30-inch deep cabinet and a secondary terminal height of 46 inches from the bottom of the cabinet (Style IIE-LB and IIF, 300 kVA and larger).

## Requirements for Bus Duct Entrance Termination Unit for Use With Pad-Mounted Transformers

5. It is recommended to install pad-mounted transformer, bus duct entrance termination box, and customer bus duct entrance box on the same monolithic pad to avoid soil settlement issues. See [Document 043818](#) or [Document 045292](#) for transformer pad dimensions.

6. Service Connection

The customer must provide a minimum of 36 inches of straight (unbent) bus duct from the bus duct entrance terminating end at the side of the pad-mounted transformer (top entry is not permitted). The customer must also supply tie straps for collecting like phases, all necessary bus extensions, and bracing for bus extensions, as required. The bus duct must enter the transformer entrance box in a “horizontal” configuration. PG&E will make the connections from the bus extensions to the transformer secondary terminals, using insulated, flexible, copper conductor provided by PG&E.

7. A termination enclosure is allowed if its installation meets the following requirements:

- A. Has the same capacity and short circuit rating as the customer’s switchboard.
- B. Installed at a distance no closer than 60” from the edge of the transformer pad.
- C. Meets Greenbook specifications as listed below:
  - 5.2.1. Approved Metering and Service Termination Equipment.
  - 5.2.2. Drawing Submittal Requirements for Metering and Service Termination Equipment.
  - 9.10. Underground Service Cable–Termination Section or Pull Box.
  - Table 9 – 4 Minimum Pad–Mounted (Floor–Standing) Switchboard Pull–Section Dimensions: Residential and Nonresidential, Single–Phase and Three–Phase.
  - Figure 9 – 15, Detail of Aluminum, Termination Bus Stubs.
  - 10.3.12. Service Terminations for Underground Services.
  - 10.3.14. Underground, Cable–Terminating Facilities in Pull Boxes or Pull Sections.

8. To provide a water tight transition between the components, the bus duct (flanged ends provided by the customer) must match the dimensions of the transition box assembly and flange plate (Detail A on Page 9).

9. Transformer Bus Duct Cover Plate

A cover used to close off the bus duct entrance hole left in a transformer when it is removed or replaced. This plate bolts into the same bolt holes used for the bus duct entrance termination box and can be installed locally so that the transformer can be reused without sending it to Emeryville to have the opening covered (Code 180203).

<b>References</b>	<b>Location</b>	<b>Document</b>
<a href="#">Connectors for Insulated Cables Underground Distribution Systems</a> .....	<a href="#">UG-1: Connectors/Greenbook</a> .....	<a href="#">015251</a>
<a href="#">Concrete Pads for Radial-Style, Three-Phase Pad-Mounted Transformers</a> .....	<a href="#">UG-1: Transformers</a> .....	<a href="#">043818</a>
<a href="#">Installation of Loop-Style, Three-Phase, Pad-Mounted Transformers</a> .....	<a href="#">UG-1: Transformers</a> .....	<a href="#">045291</a>
<a href="#">Concrete Pad for Three-Phase, Loop-Style, Pad-Mounted Transformers</a> .....	<a href="#">UG-1: Transformers/Greenbook</a> .....	<a href="#">045292</a>
<a href="#">Terminating Underground Electric Services 0–600 Volts in Customer-Owned Facilities</a> .....	<a href="#">UG-1: Services/Greenbook</a> .....	<a href="#">058817</a>
<a href="#">Methods and Requirements for Installing Commercial Underground Electric Services 0-600 Volts to Customer-Owned Facilities</a> .....	<a href="#">UG-1: Services/Greenbook</a> .....	<a href="#">063928</a>

## Requirements for Bus Duct Entrance Termination Unit for Use With Pad-Mounted Transformers

---

### Installation

#### Notes

1. Method of installation (see Figure 1 on Page 4) - The location of the edge of the pad must first be established by consultation between PG&E and the building architect or contractor. The bus duct termination end flange and flange plate must be located such as to permit its connection to the bus duct entrance termination box at a point 23 inches to 24 inches from the edge of the pad. The vertical centerline of the bus duct entrance termination box must be located 23 inches from the front edge of the transformer pad (see Figure 1, Section A-A and Figure 2, Section B-B on Page 4). Additionally, there must be a minimum of 60 inches straight length between the edge of the pad and any obstruction (bend, support, apparatus, wall or building, etc) in the bus duct to accommodate the 48" long bus duct entrance termination box provided by PG&E.

These dimensions will accommodate all style IIB, IIC, IIE, IIF, IIG, and IIH transformers used in bus applications.

2. Bus duct flange plate (see Detail A on Page 9) - A removable bus duct end flange plate must be provided by the customer at the transformer end of the bus duct. This plate must not be drilled. PG&E will locate and drill 1/2-inch diameter holes in the flange plate to match the square holes in the adjustable end flange of the entrance box.
3. Transformer cabinet bus duct cutout - The horizontal centerline of the bus duct termination box in the side of the transformer must be approximately 24 inches above the top of the pad. The cutout dimensions and drilling for bolt holes must match the dimensions and drilling of the entrance box, as determined in the field. A template is provided in the kit to help in positioning the flanged end and locating the mounting holes.
4. Bus duct connections in transformer (see Figure 3 on Page 5)
  - A. For two and three bars per phase, the customer must provide tie straps bolted across like phases where they enter the transformer entrance box.
  - B. PG&E will provide the flexible copper conductor and spade connectors necessary to make the connection between the secondary spades of the transformer and the customer's bus duct.
  - C. The customer must furnish the tie bars (Section F-F on Page 9) and spacers (Detail D on Page 9) with the bus duct. The bus duct must be in a horizontal configuration when entering the entrance box.
  - D. PG&E will provide the necessary spade supports for the protection of the transformer. See [Document 045291](#) for further information on the secondary cable support kit (M019644).
5. Feeder bus duct and entrance box supports - Feeder bus duct supports (where necessary) are required to be installed by the customer. The entrance box must not be used as a bus duct support. PG&E will provide and install a support (supports are not part of a kit) for the bus duct entrance termination box, as shown in Figure 1 and Figure 2 on Page 4, and Detail F on Page 10.

## Requirements for Bus Duct Entrance Termination Unit for Use With Pad-Mounted Transformers

### Installation (continued)

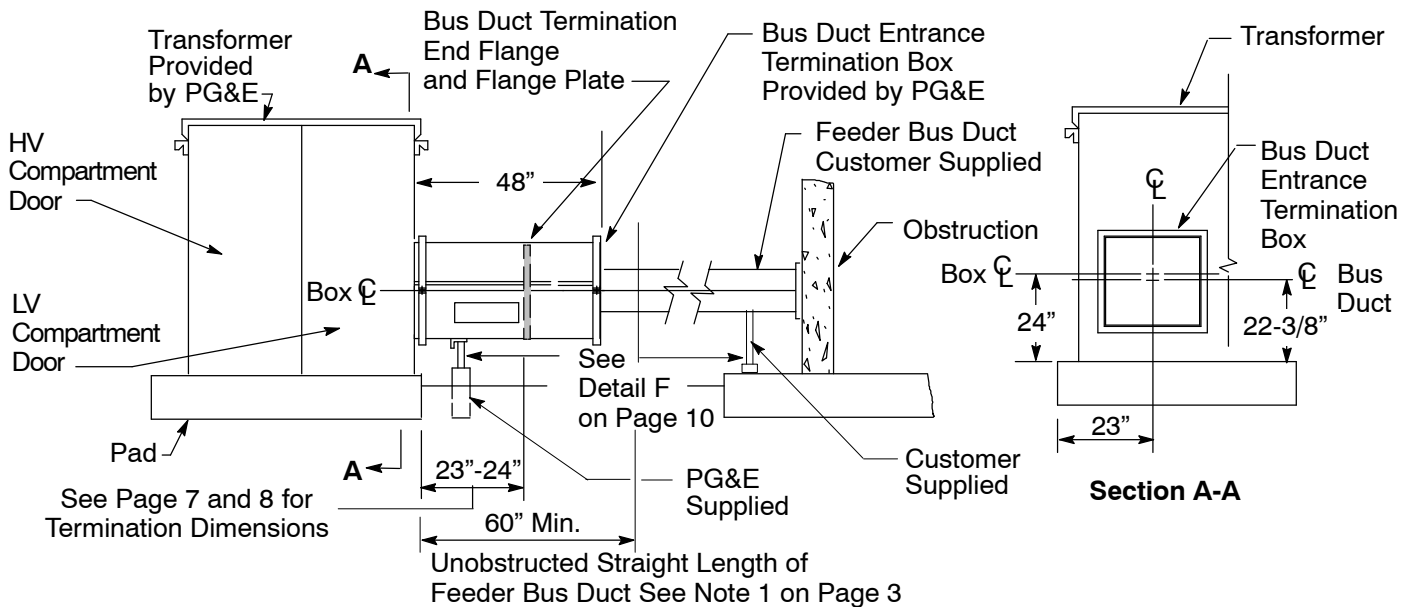

**Figure 1**  
**Typical Bus Duct Assembly for Largest Pad-Mounted Transformer**

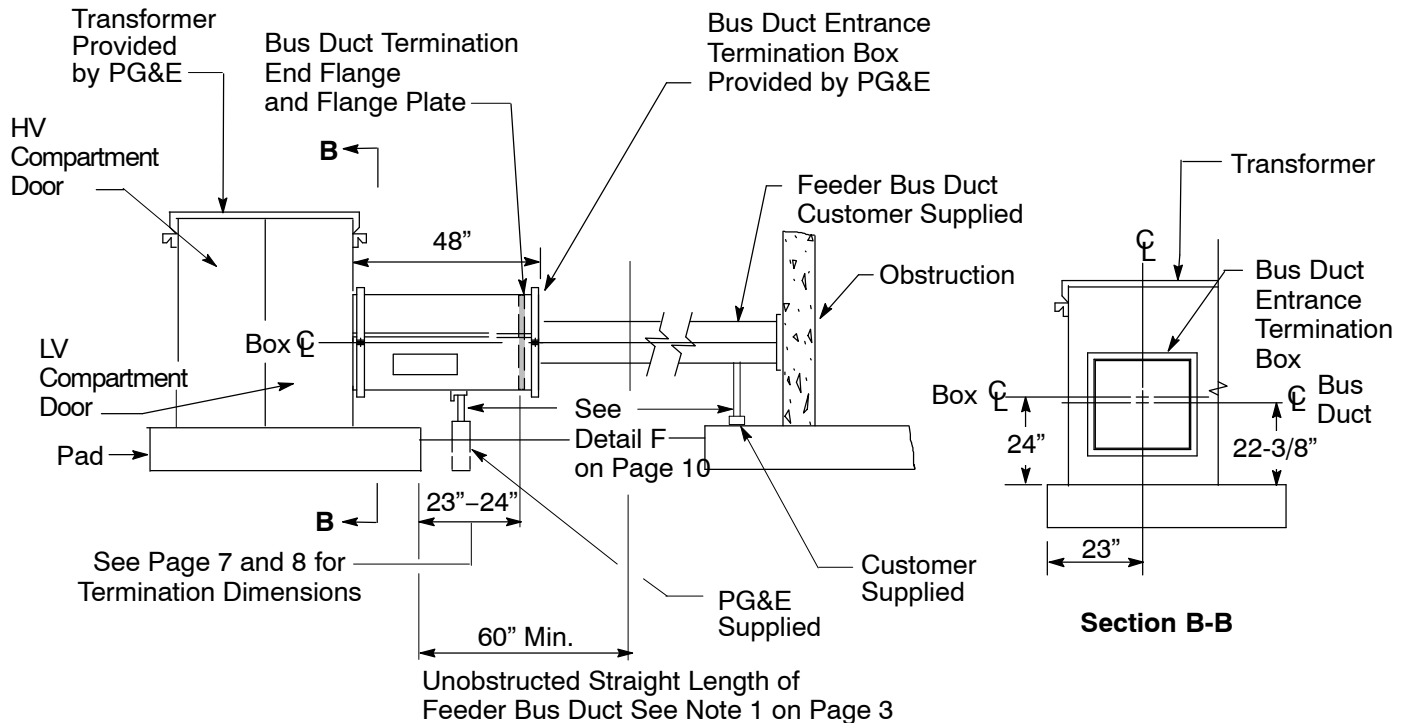
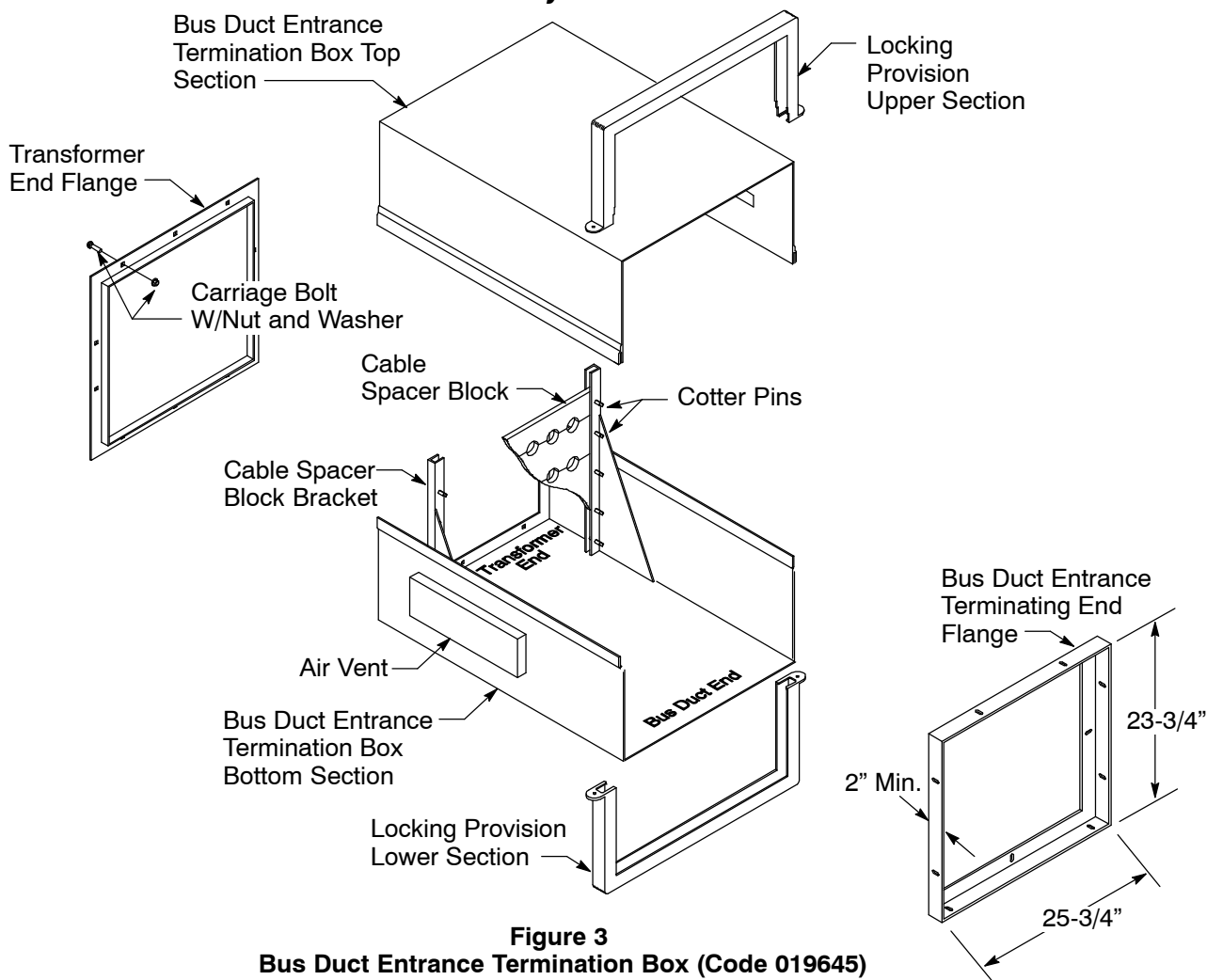

**Figure 2**  
**Typical Bus Assembly for Smallest Pad-Mounted Transformer**

Note: Dimensions in all Figures are not to scale.

## Requirements for Bus Duct Entrance Termination Unit for Use With Pad-Mounted Transformers

### Bus Duct Entrance Termination Box Assembly



**Figure 3**  
**Bus Duct Entrance Termination Box (Code 019645)**

**Table 1 List of Material for Bus Duct Entrance Termination Box Kit <sup>1</sup>**

Quantity	Description
1	Stainless Steel Bus Duct Entrance Termination Box
1	Cable Spacer
4	Copper Bus Bar Extensions <sup>2</sup> (see Detail E on Page 10)
24	1" x 3/8" Carriage Bolts With Nuts and Washers
2	3/8" x 3-1/2" Bolt, With Nut and 3/16" Diameter Hole for Safety Lock
2	Safety Locks, Utilco Catalog Number PEL-1, Code 170115
10-Foot Length	Weather Stripping
1	Template

<sup>1</sup> When needed, use and order secondary cable support kit M019644 (see [Document 045291](#)). This kit is not included in the bus duct termination box kit.

<sup>2</sup> See Page 6 for additional information on copper bus bar extensions.

## Requirements for Bus Duct Entrance Termination Unit for Use With Pad-Mounted Transformers

### ***Bus Duct Entrance Termination Box Assembly (continued)***

Copper bus bar extensions are available as a component of the bus duct entrance termination box kit (Code M019645), and can also be ordered separately. (Code M310028).

The copper bus bar extensions are used when additional secondary cable is added to the transformer and the terminal spades do not have enough room to accommodate the additional cable.

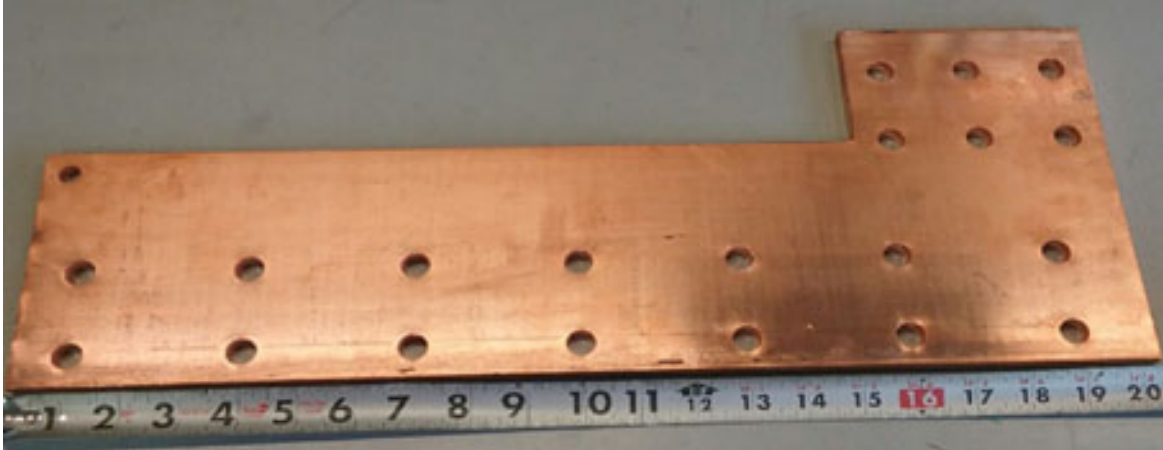

**Figure 4**  
**Copper Bus Bar Extension**

**Table 2 Recommended Tools for Assembly and Installation of Bus Duct Entrance Termination Box**

Description	Code
Sawzall, Heavy Duty, Milwaukee #6511-W/Case	210075
Blades, Sawzall, Milwaukee #48-00-1171 – Package of 10	207674
Drill, Skil #6550, 1/2" Variable Speed Reversible	210026
Drill Bit Set, 1/16" to 1/2", W/Case	203026
Punch, Center, 3/8"	201305

## Requirements for Bus Duct Entrance Termination Unit for Use With Pad-Mounted Transformers

### Bus Duct Termination Assembly – Fully Extended

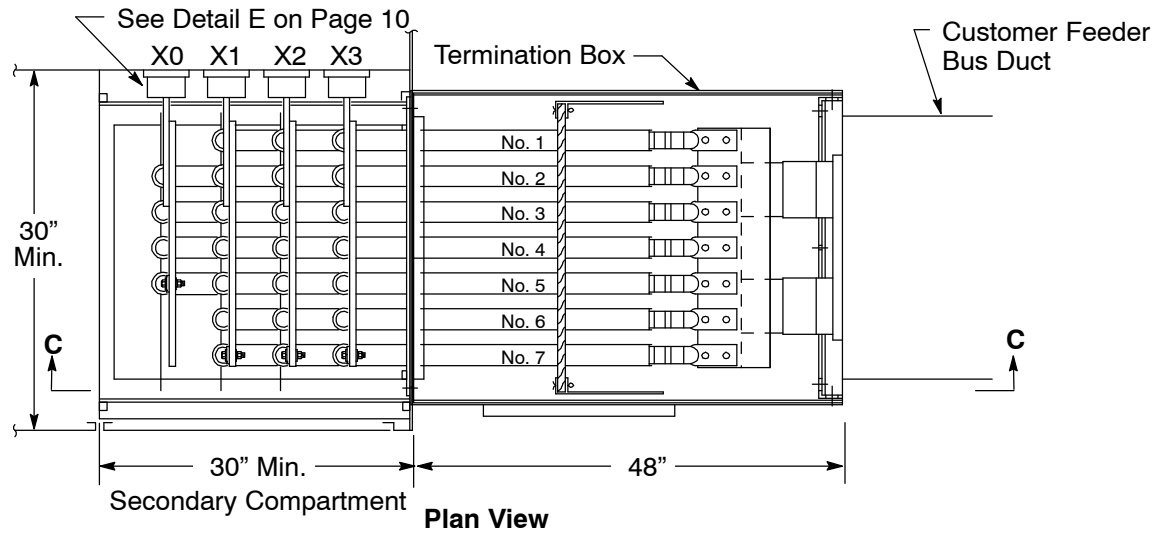

**Typical Outdoor Bus Termination Fully Extended**

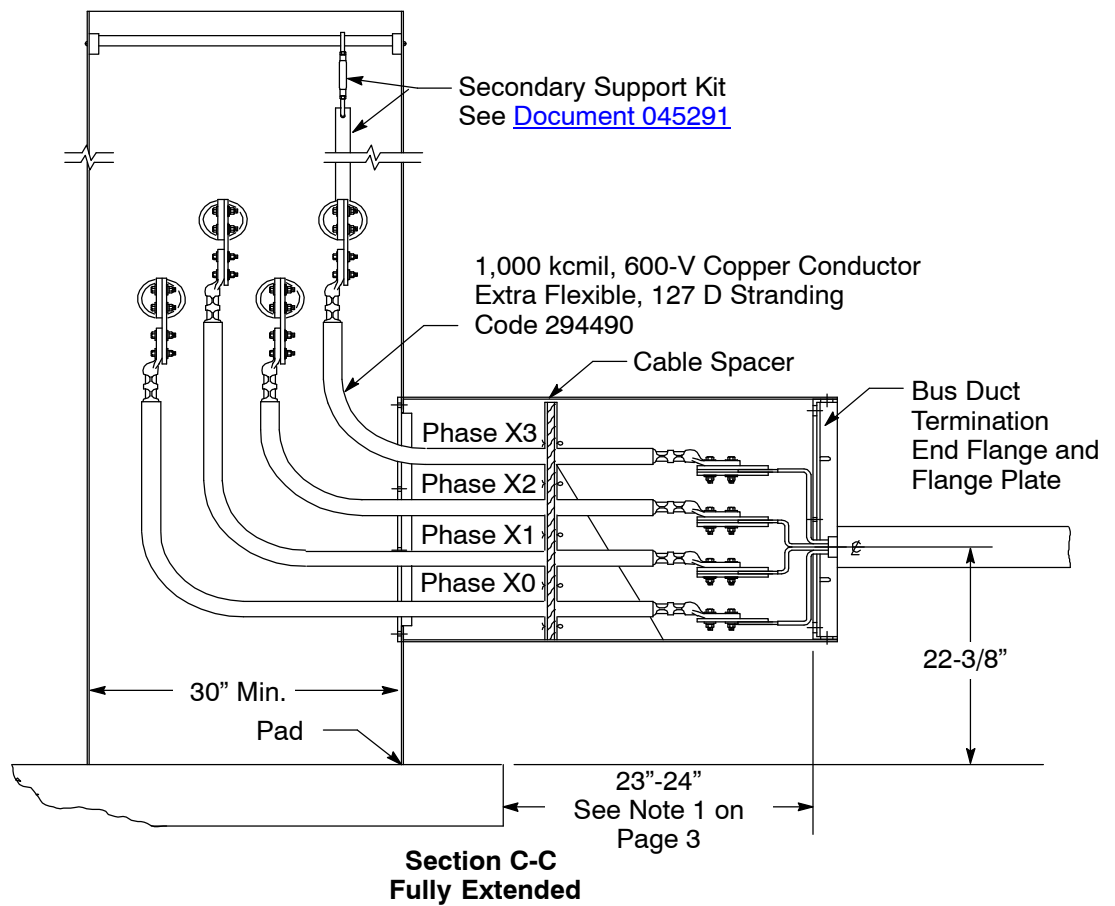

**Figure 5  
Bus Duct Termination Assembly Fully Extended**

## Requirements for Bus Duct Entrance Termination Unit for Use With Pad-Mounted Transformers

### Bus Duct Termination Assembly – Fully Compressed

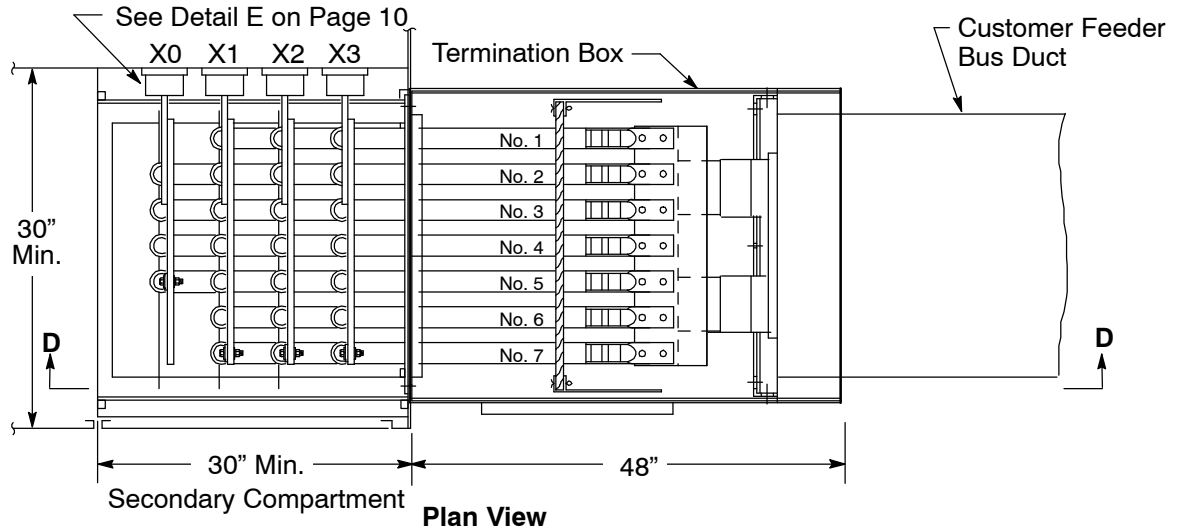

**Typical Outdoor Bus Termination Fully Compressed**

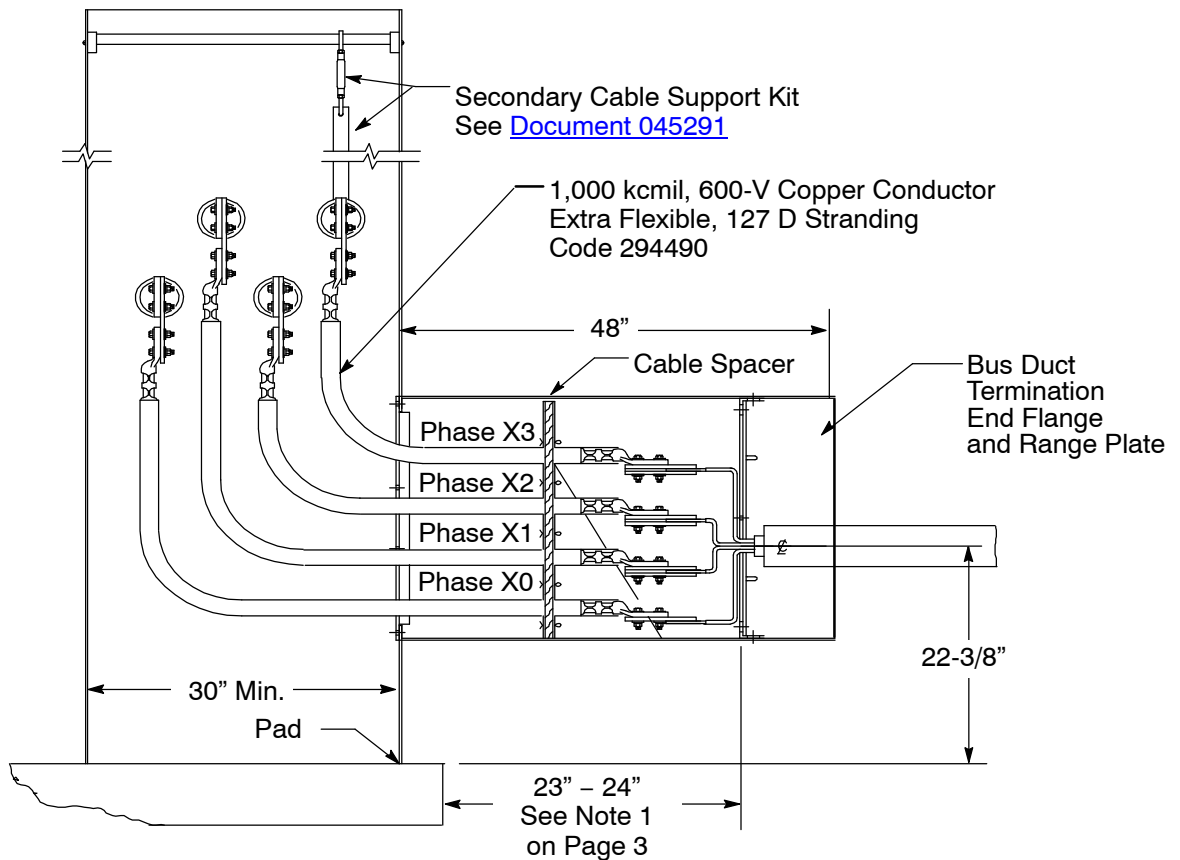

**Section D-D  
Fully Compressed**

**Figure 6  
Bus Duct Termination Assembly Fully Compressed**



## Requirements for Bus Duct Entrance Termination Unit for Use With Pad-Mounted Transformers

### Bus Duct Termination Assembly – Details

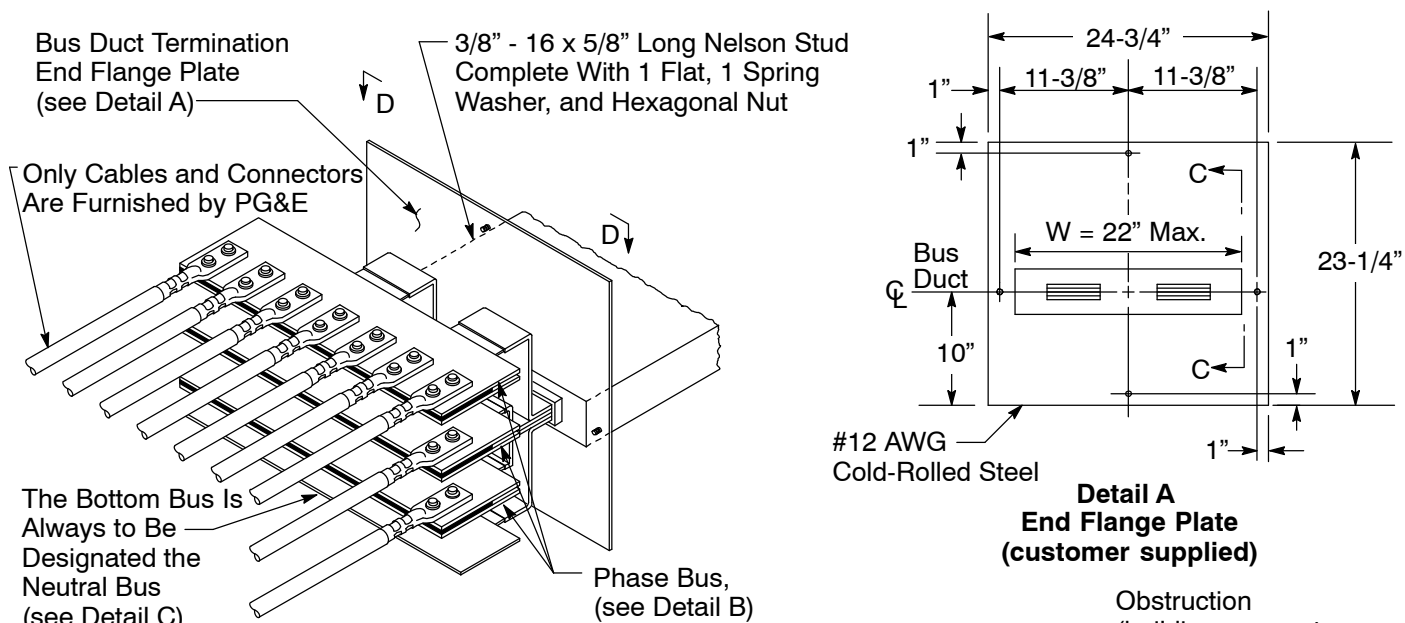

**Figure 7**  
**Termination Detail With**  
**Bus Duct End and Tie Bars**

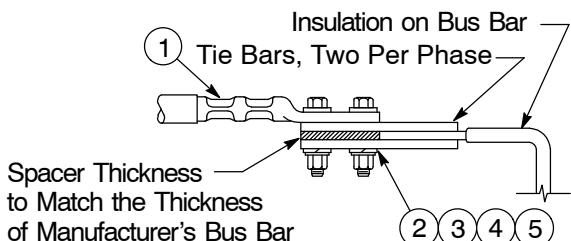

**Detail B**  
**Typical Phase Bus Termination Assembly**

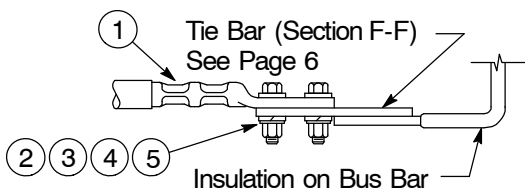

**Detail C**  
**Typical Neutral Bus Termination Assembly**

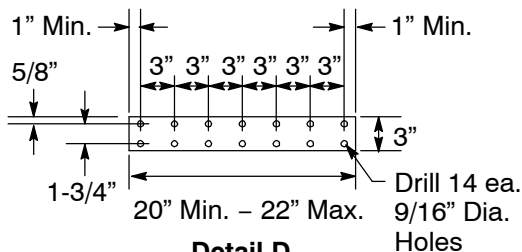

**Detail D**  
**Spacer 3\"/>**

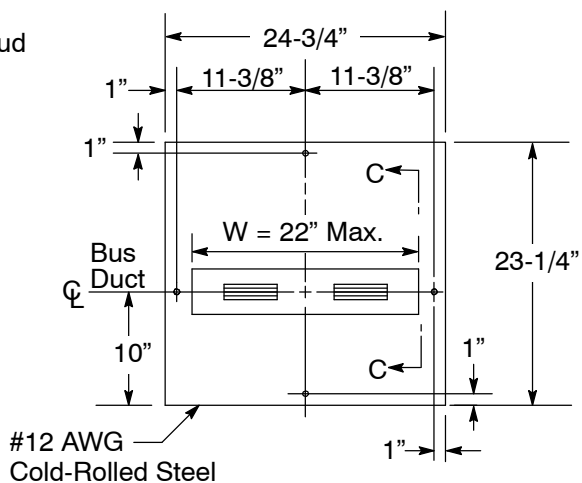

**Detail A**  
**End Flange Plate**  
**(customer supplied)**

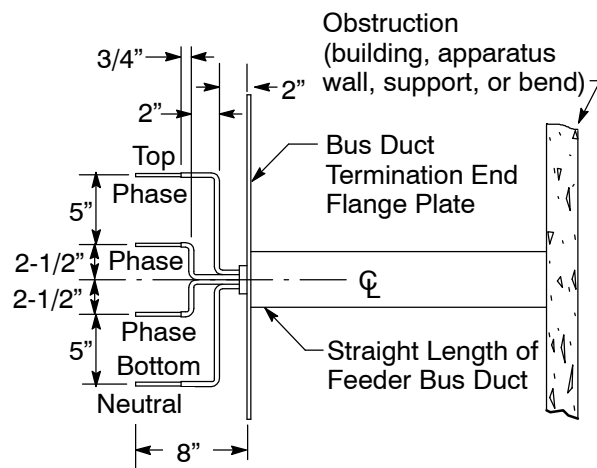

**Section E-E**  
**Bus Bar**  
**(customer supplied)**

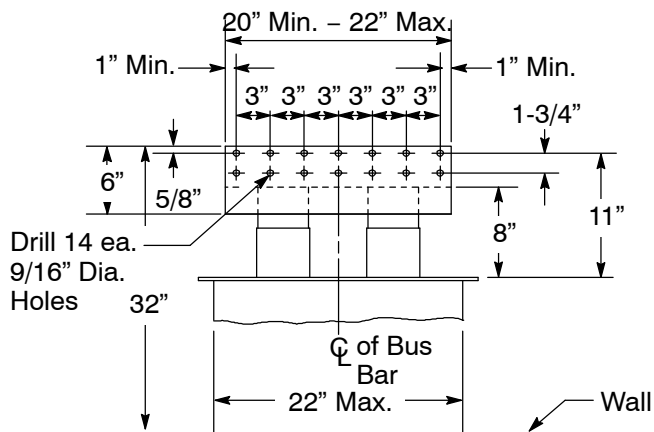

**Section F-F**  
**Tie Bar Connection 1/4\"/>**

## Requirements for Bus Duct Entrance Termination Unit for Use With Pad-Mounted Transformers

### Bus Duct Termination Assembly – Details (continued)

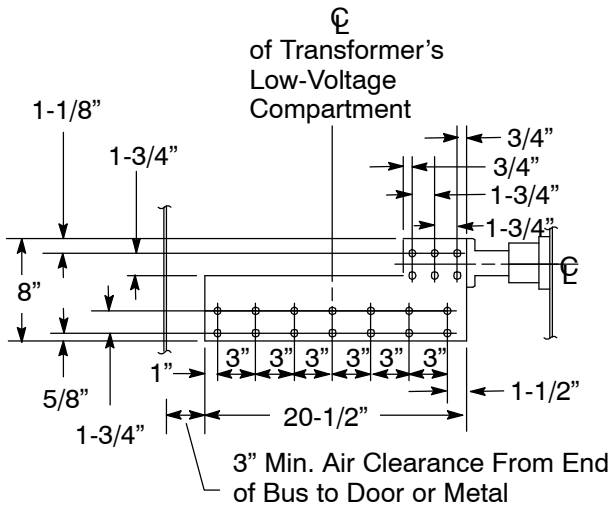

**Detail E**  
**Copper Bus Bar Extension**  
(see Table 1 on Page 5)

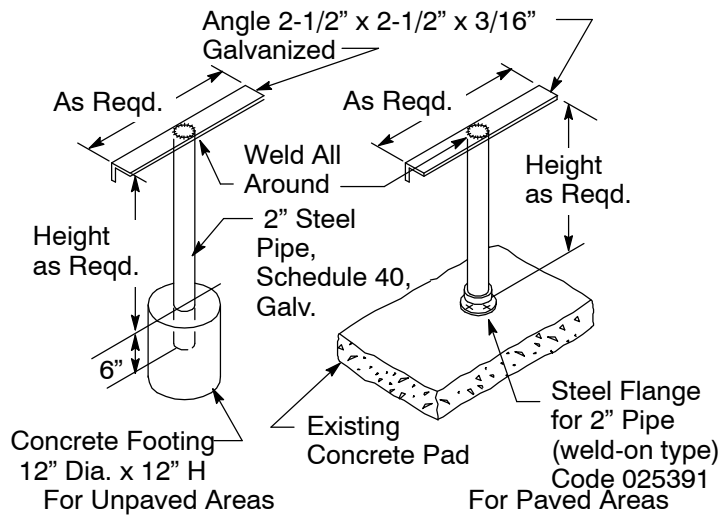

**Detail F**  
**Termination Unit Supports**  
(PG&E supplies one under the bus duct  
termination box. Customer supplies remainder as required.)

**Table 3 Copper Conductor Requirements<sup>3</sup>**

Main Switch Rating	Number of Conductors Per Phase	Number of Neutral Cables	Approximate Footage of Conductor
2,500	4	2	140
3,000	5	3	180
3,500	6	3	210
4,000	7	4	250

<sup>3</sup> Use only 1,000 kcmil copper cable (Code 294490).

**Table 4 List of Materials for Bus Termination Assemblies (see Detail B and Detail C on Page 9)**

Item	Description	Code	Document
1	Terminal Connector, Compression-Type, Cable-to-Flat, for 1,000 kcmil Cable	303461	<a href="#">015251</a>
2	Screw, Cap (bolt), Hex. Head, 1/2" x 2-1/2", Everdur or Equivalent	193177	–
3	Nut, Bolt, Hex., 1/2", Everdur or Equivalent	195013	–
4	Washer, Round, 1/2", Everdur or Equivalent	195252	–
5	Washer, Lock, 1/2", Everdur or Equivalent	195193	–

### Revision Notes

Revision 12 has the following changes:

1. Revised Notes 2E and 3B on Page 1.
2. Updated Reference links to TIL Viewer.
3. Delete the word joint in Note 1 on Page 3.
4. Added Notes 1 and 2 and Figure 4 on Page 6.
5. Replace the word shall with must throughout document.