	PAD-MOUNTED TRANSFORMER INSTALLED INDOORS	057521
Asset Type: Electric Distribution		Function: Design and Construction
Issued by: M. L. Thibault (MLTC)		Date: 08-15-17
Rev. #11: This document replaces PG&E Document 057521, Rev. #11. For a description of the changes, see Page 21.		

This document is also included in the following manuals:

- [Electric and Gas Service Requirements Manual](#) (Greenbook)
- [Electric Meter Work Practices](#)

Purpose and Scope

This document provides a guide for determining space requirements and illustrates recommended layouts to accommodate three-phase, loop, or radial circuit, pad-mounted transformers installed in a dry room located inside or adjacent to a customer's building. The room is usually provided by the customer.

General Information

1. A dry room is one which:
 - A. Is located at/or above ground level, or
 - B. Is located below ground level, and
 - (1) Is completely contained within the building's foundation.
 - (2) Is so designed that flood water entry is prevented.
 - (3) Has sufficient gravity drainage to prevent water retention.
2. It is best that the doorway of the room opens to the street. However, the doors may open to a parking area or driveway provided that access is maintained from the street to the doors. The access path must be at least 11 feet wide.
3. The room must be large enough to accommodate a transformer capable of supplying 100% of the main switch capacity. Enlarging a transformer room is very costly and sometimes entirely impractical.
4. Eight feet of clear level space **must** be provided in front of the transformer cabinet, in order that the fuses and cables can be safely operated with live-line tools.
5. Ventilation design must conform to the requirements in [Document 054163](#). The location of the vent shafts may be adjusted to meet local conditions. Cross ventilation must always be maintained.
6. The room itself must conform to all applicable state and local codes. The applicant is responsible for installing and maintaining any items such as sprinklers, smoke alarms, etc. that may be required by local authorities.
7. It is preferable to have access to a room via an outside entrance which would be accessible to authorized Company employees at all times (i.e., from parking lot, loading ramp, street, etc.). However, should it become necessary to accept access through the customer's premises, arrangements should be made to ensure that complete access for both equipment and authorized Company employees is available whenever required. Inadequate access will result in prolonged outages.
8. The room shall be designed with adequate security to permit entrance only to authorized personnel.
9. Cable troughs rather than conduits are required to allow the cables to be pulled out of the way of jacking and rolling the transformer out of the room.

10. The applicant will own and construct the transformer room and any associated substructures on its property. This provision is in accordance with the rates filed with and approved by the CPUC. The room must meet all city, county, and state codes and regulations, as well as PG&E's requirements for the safe installation, removal, and operation of its equipment.
11. PG&E must review and approve a not-for-construction drawing prior to the construction of the vault. Once approved, PG&E will forward it and the associated specification sheets to the applicant for his/her use and distribution to the general contractor. It is the responsibility of the applicant to notify PG&E of any design or construction changes. PG&E must review and approve these changes before proceeding with the design or construction of the vault.
12. It is the applicant's responsibility to contact PG&E's inspection department prior to the construction of the transformer room. PG&E will inspect the transformer room as it is being built to assure the proper installation and placement of various items required to ensure a safe working environment. PG&E equipment will not be installed until the room has been completed and the work area is clear of any debris. PG&E's inspection department must accept and sign off the room before energizing the new service. To schedule a room inspection appointment, please call _____.
13. No foreign objects shall pass through or terminate in the transformer room. The use of surface-mounted rigid electrical conduits and outlet boxes is allowed provided they are waterproof and approved by the local authorities.
14. Provide 3-hour fire rated concrete reinforced structure, including cable troughs, room walls, floor, and ceiling. Cover all exposed structural steel with 3-hour fire rated flameproof material. Seal off all openings to the interior of the building with approved caulking material. Intake and exhaust vents must be constructed with 3-hour fire dampers.
15. The doors must:
 - A. Be 3-hour fire rated.
 - B. Be capable of being secured while in the open position.
 - C. Open sufficiently so that within 2' of the 8' 6" doorway the path for the transformer installation and removal must open up to at least 11' wide.
 - D. Open sufficiently so as not to impede the sidewalk.
16. Provide a minimum of two lights with a minimum 30 foot-candle illumination. Provide convenient GFI duplex receptacles. Maintain 60 inches above the finish floor for receptacles and switches. Provide power for all equipment from the applicant's emergency power supply. Also see [Document 054438](#).
17. Provide pulling eyes (Code 36-2029) with a working load of 10,000 lbs. times a safety factor of two. Install the pulling eyes 36" above the finished floor with 4 inches of clear space between the steel and wall surface. Center them directly across from the door opening and the end of each cable trough. Submit an engineered wet stamped drawing to PG&E for its approval for any pulling eye deviations. Also see [Document 09219](#).
18. The room floor must support the total weight of PG&E equipment plus 2,000 lbs. and maintain a minimum of 10 feet ceiling height for moving the equipment.

Secondary Configuration

19. The secondary configuration depends on the main switch size and whether or not there is an associated fire pump main.
 - A. For main service of up to 7 sets of cables per Greenbook [Document 063928](#) **without** a separate fire pump service, or where the combined mains of the service and fire pump do not require more than 8 cables, the secondary are cables in an open trench to conduits stubbed through the right-side or rear vault wall (see Figure 1 on Page 5). Alternately, the cables may terminate on a wall-mounted bus stub.
 - B. For main service of up to 7 sets of cables per Greenbook [Document 063928](#) **with** a separate fire pump service, the secondary is made of cables in an open trench to wall-mounted bus stubs that feed adjacent stubs to the fire pump (see Figure 4 on Page 8).
 - C. For bus duct main service per Greenbook [Document 063928](#) **without** a separate fire pump service, the applicant provides a bus duct termination through the vault wall (see Figure 7 on Page 11).
 - D. For bus duct main service per Greenbook [Document 063928](#) **with** a separate fire pump service, the secondary is made of cables in an applicant-installed cable tray from the side of the transformer to wall-mounted bus stubs that then also feed an adjacent bus stub to the fire pump (see Figure 9 on Page 13).

Pad-Mounted Transformer Installed Indoors

- E. The fire pump main must be dedicated to emergency equipment and must not exceed 2,000 A. With combined services, running the emergency equipment will require curtailing regular load. There shall be a permanent sign on or near the fire pump controls indicating that regular load must be curtailed when running the fire pumps.
20. Provide a _____ CFM forced air ventilation system from outside air via direct-drive, AMCA Type A or B spark resistant, fan with an explosion proof motor (intake) and high exhaust vent opening. Install 1/2-inch mesh screen on both sides of the fan assembly (see [Document 054163](#)). Install a remote thermostat sensor at the exhaust opening and a separate thermostat control 60 inches above finished floor. Set thermostat between 85°F and 90°F . All vent openings shall have a minimum of 576 square inches of opening.
 21. Provide two 3/4" X 12" ground rods with 12" exposed above finished floor, as shown in the plan view. Ground rods are not to be altered in any way and must maintain a minimum of 6 feet of separation between them. Install #2 Solid CU ground wire in a loop as indicated between the ground rods. PG&E will inspect all ground rods prior to covering. Provide tests and documentation for deviations to this procedure to substantiate the resistivity of the ground rods (see [Document 060462](#)).
 22. Provide a 6-inch removable sill across all entrances for oil containment after transformer(s) are installed. Caulk all gaps leading to the interior of the building. Provide a Corbin lock set with tumbler (CL3357-N2D-626 or CK4257-GRC-626) for the vault door(s). PG&E will key the tumblers. Provide provisions to lock the door in the open position for emergency purposes.
 23. All exposed metal in the vault must be grounded.
 24. Room to be designed and built as a Class 1, Zone 1, reference California Subchapter 5, Electrical Safety Orders, Article 59, hazardous (classified) locations.

References	Location	Document
Draw Bolt for Electric Manholes	ELS	09219
Corrosion Resistant Ground Rods and Ground Rod Clamps	UG-1: Connectors/Greenbook	013109
Connectors for Insulated Cables Underground Distribution Systems	UG-1: Connectors/Greenbook	015251
Cable Support for Underground Use	UG-1 Splices	028077
Tags for Identifying Underground Cables and Equipment	UG-1: Marking	033582
Premolded 200-Amp Terminations for Primary Underground Cable	UG-1: Terminations	035314
Cables for Underground Distribution	UG-1: Cable	039955
Service Entrance from Underground Vault Using Bus Bars	UG-2: Transformers	041352
Loop-Style, Three-Phase, Pad-Mounted Transformers Installation of Loop-Style, Three-Phase, Pad-Mounted Transformers	UG-1: Transformers/EMWP	045290
Concrete Pad for Three-Phase, Loop-Style, Pad-Mounted Transformers	UG-1: Transformers	045291
Concrete Pad for Three-Phase, Loop-Style, Pad-Mounted Transformers	UG-1: Transformers/Greenbook	045292
Ventilation of Vaults and Manholes	Electric Design Manual	054163
Installation of Wiring for Lighting and Auxiliary Equipment in Vaults and Manholes	UG-2: Enclosures	054438
Terminating Underground Electric Services 0-600 Volts in Customer-Owned Facilities	UG-1 Services/Greenbook/EMWP	058817
Grounding of Underground Equipment	UG-1: General	060462
Fault Indicators for Underground Application	UG-1: General	061683
Underground Conduits	UG-1: Conduits	062288
Methods and Requirements for Installing Commercial Underground Electric Services 0-600 Volts to Customer-Owned Facilities	UG-1: Services/Greenbook	063928

References (continued)	Location	Document
Requirements for Bus Duct Entrance Termination Unit for Use With Pad-Mounted Transformers	UG-1: Services/Greenbook	063929
Corporation Padlock	TIL	068200

Table 1 Bill of Materials for Three-Phase, Pad-Mounted Transformer

Item	Description	Code	Document
1	Transformer, Pad-Mounted, Three-Phase (as required)	-	045290
2	Cable, Insulated, Single-Conductor, Primary, 1/0 Minimum	-	039955
3	Cable, Insulated, Single-Conductor, 600 V (size as required)	-	039955
4	Conduit (size as required) (by applicant)	-	062288
5	Ventilating Fan (as required) (by applicant)	-	054163
6	Lighting (as required) (by applicant)	-	054438
7	Wire, Ground, Number 2 AWG Solid, Bare Copper (by applicant)	290074	-
8	Terminal Connector, Compression-Type	-	015251
9	Connector, Ground Terminal	303214	
10	Clamp, Ground Rod, 3/4"	187017	013109
11	Anchor Bolt, 3-1/2" x 1/2"	190445	-
12	Padlock, Corporation (for exterior locking)	016583	068200
13	Cable Sectionalizing Tag	-	033582
14	Phase Description Tag	-	
15	High Voltage/Maintain 8' Clearance Label	621599	
16	Transformer Number Decal	-	013109
17	Ground Rod, 3/4" x 12' (by applicant)	010098	
18	Grating, Steel, Removable, Non-Skid (see Detail D on Page 19) (by applicant)	-	-
19	Duct Spacers (see Detail C on Page 19) (by applicant)	-	-
20	Insulated Bushing Well Plug	300486	035314
21	Spare Concentric Wire	-	-
22	Connector, Ground Terminal	302314	-
23	200-Amp Primary Termination: Load-Break or Dead-Break Elbow Receptacles	-	035314
24	200-Amp Bushing Insert: Load-Break (300481) or Dead-Break (303920)	-	

Pad-Mounted Transformer Installed Indoors

Layout for Up to 7 Service Cables

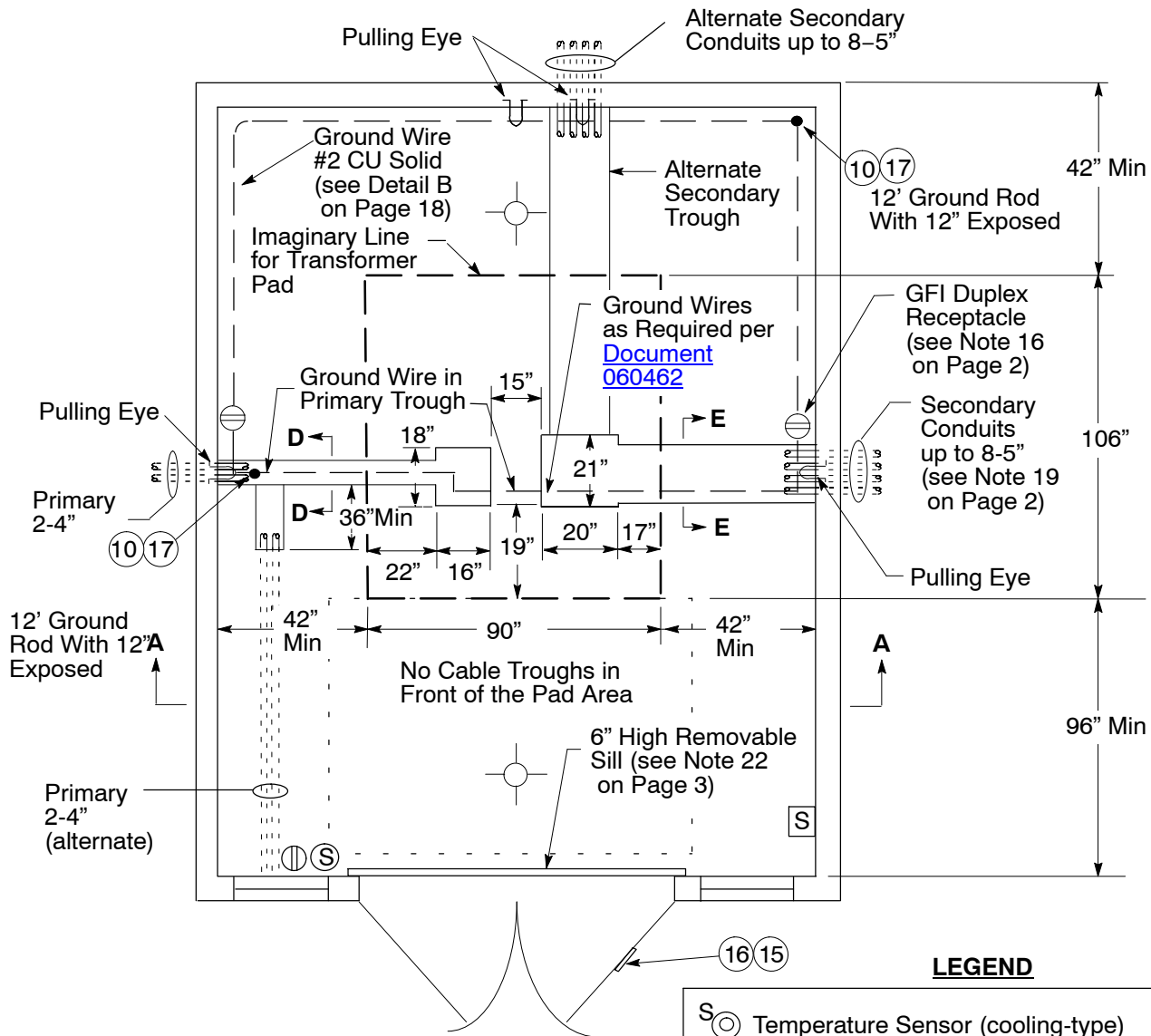

Figure 1
Dry Vault - Plan View
For Up to 8 Sets of Service Cables
(see Note 19 on Page 2)

LEGEND	
	Temperature Sensor (cooling-type)
	Thermostat Control (60" above finished floor)
	Fan Cutoff Switch (60" above finished floor)
	GFI Duplex Receptacles (60" above finished floor)
	Light Switch (60" above finished floor)
	3/4" x 12" Ground Rod
	Light Fixtures
	Pulling Eye (see Note 17 on Page 2)

Note

1. Primary may also be routed to back wall of vault. Primary may not be routed from primary section of transformer to the back wall underneath the transformer.

Layout for Up to 7 Service Cables (continued)

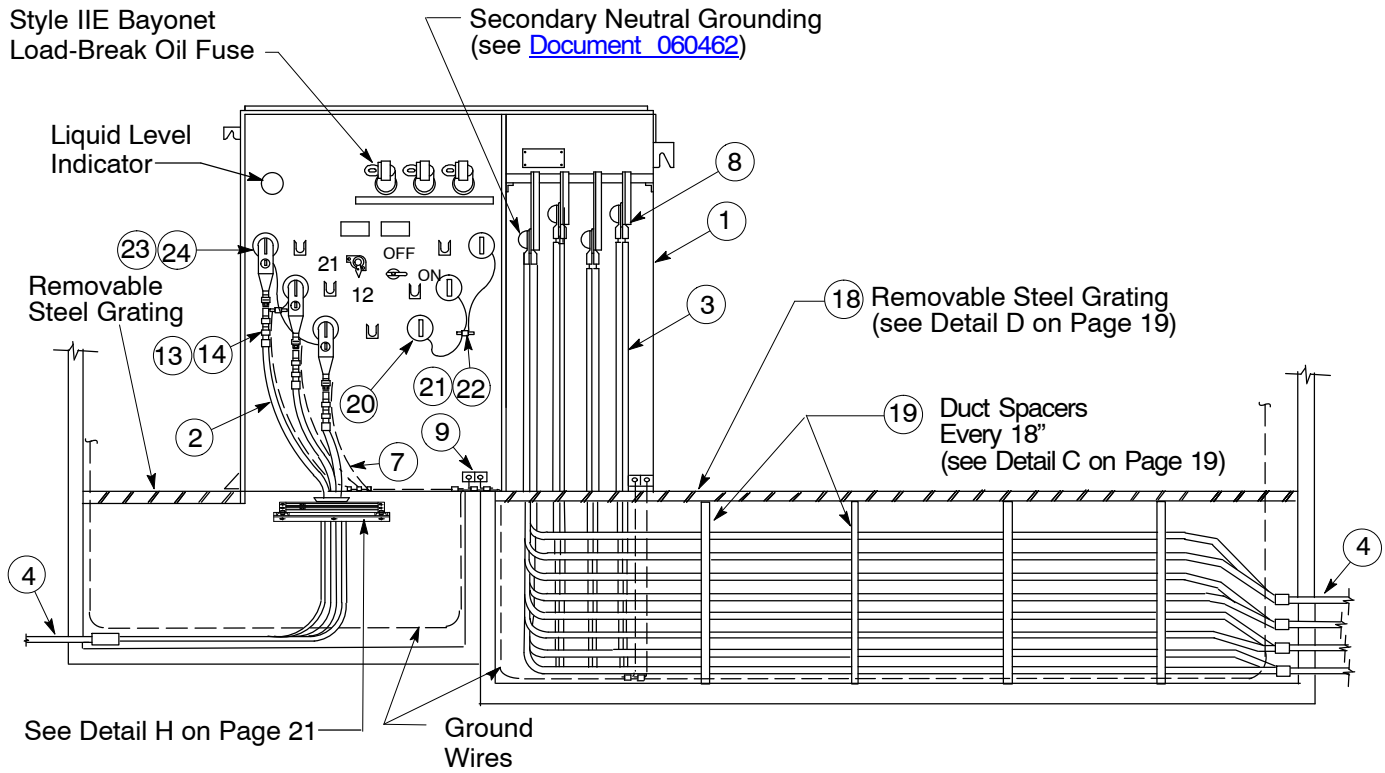

Section A-A

Figure 2
Transformer Installed
Front View
For Up to 8 Sets of Service Cables
(radial primary installation shown)

Pad-Mounted Transformer Installed Indoors

Layout for Up to 7 Service Cables (continued)

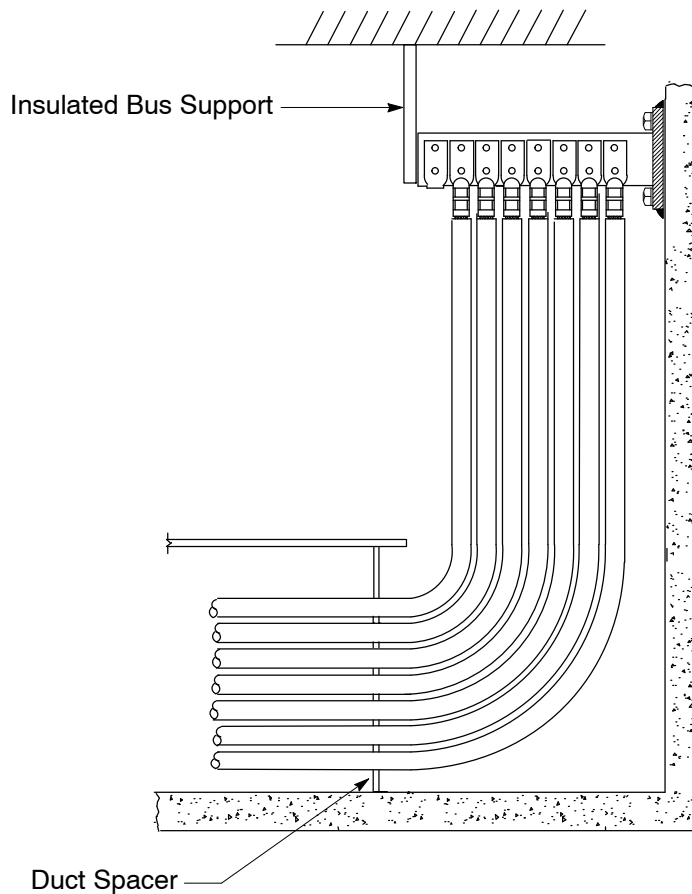

Figure 3
Alternate Secondary Cable Trench End for Bus Duct Termination
Side View
(see Details D, E, F on Page 20)

Pad-Mounted Transformer Installed Indoors

Layout for up to 8 Service Cables with Separate Fire Pump (continued)

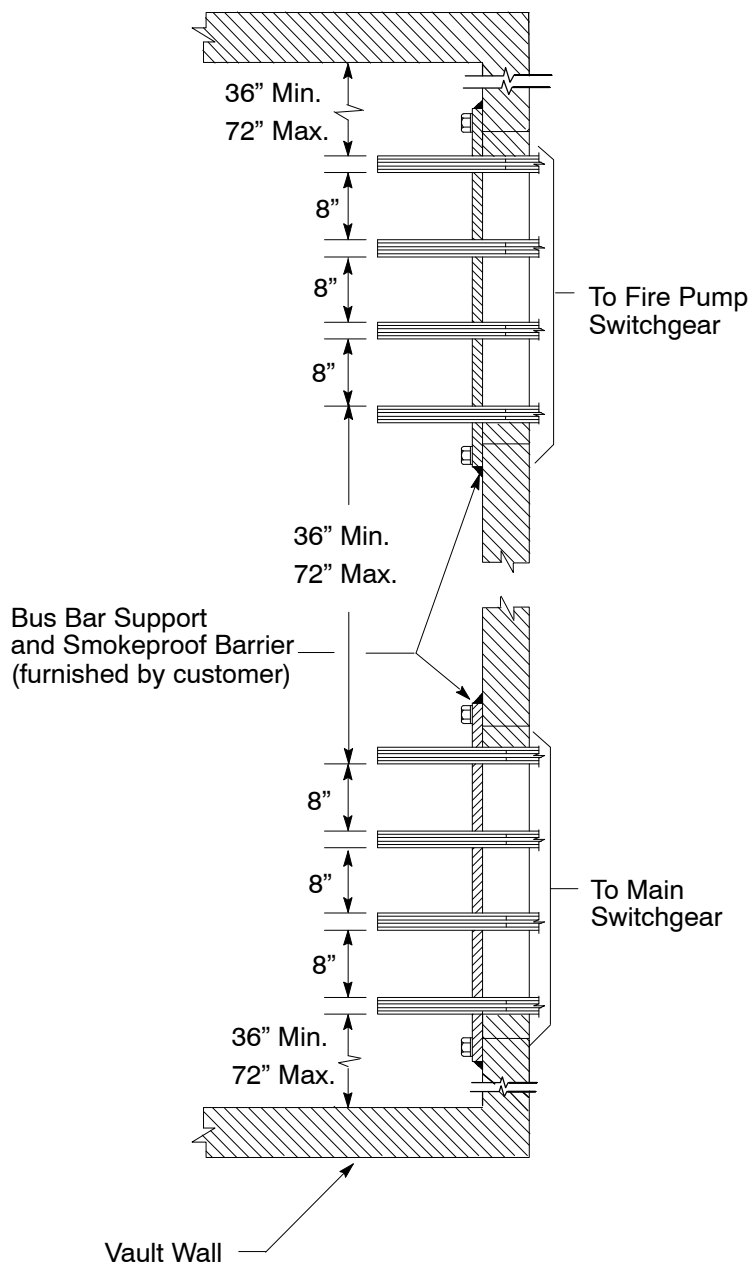

Figure 5
Service Connection - Top View
(see Details D, E, F on Page 20)

Layout for up to 8 Service Cables with Separate Fire Pump (continued)

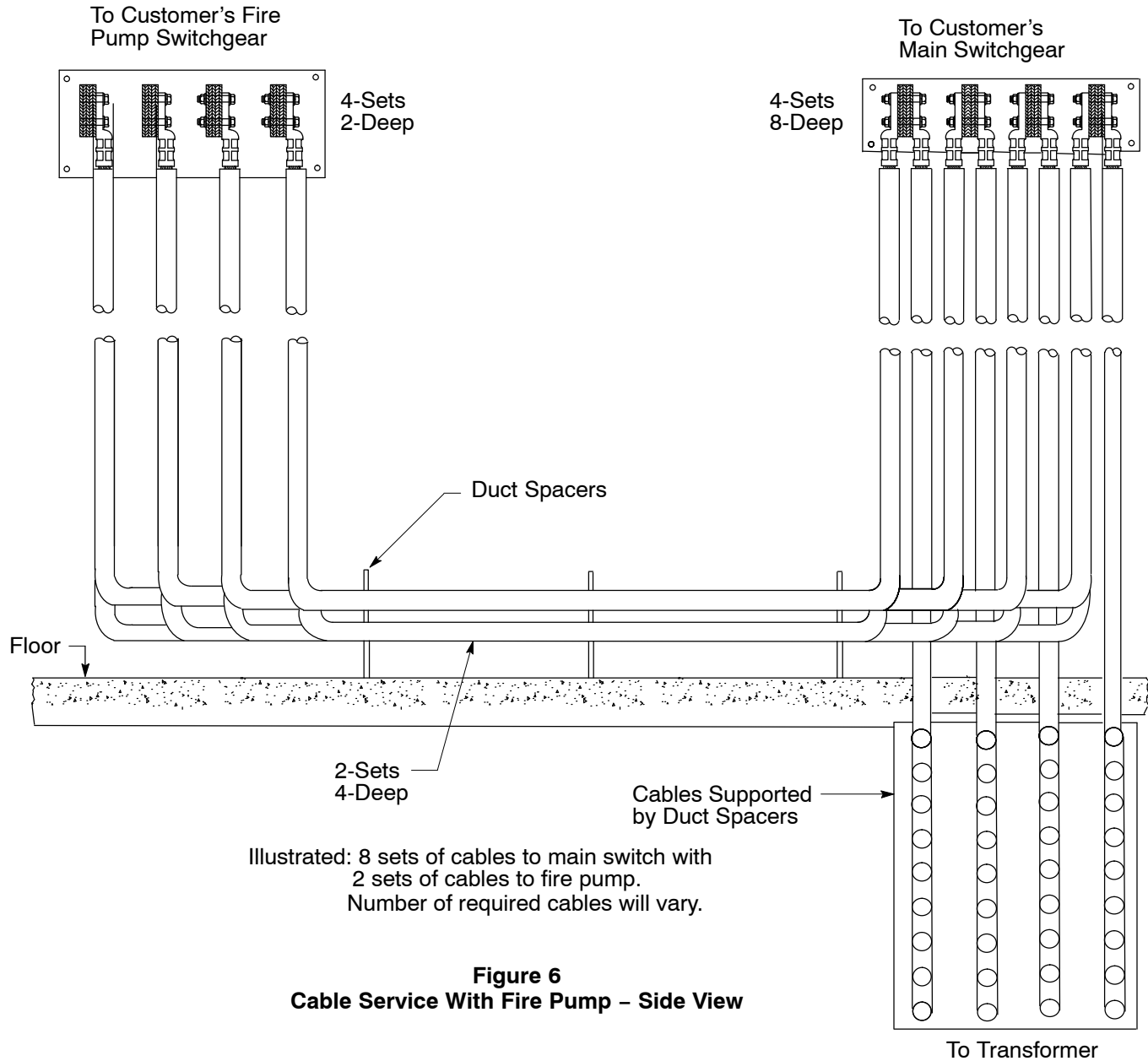

Figure 6
Cable Service With Fire Pump – Side View

Pad-Mounted Transformer Installed Indoors

Layout for Bus Duct with no Separate Fire Pump

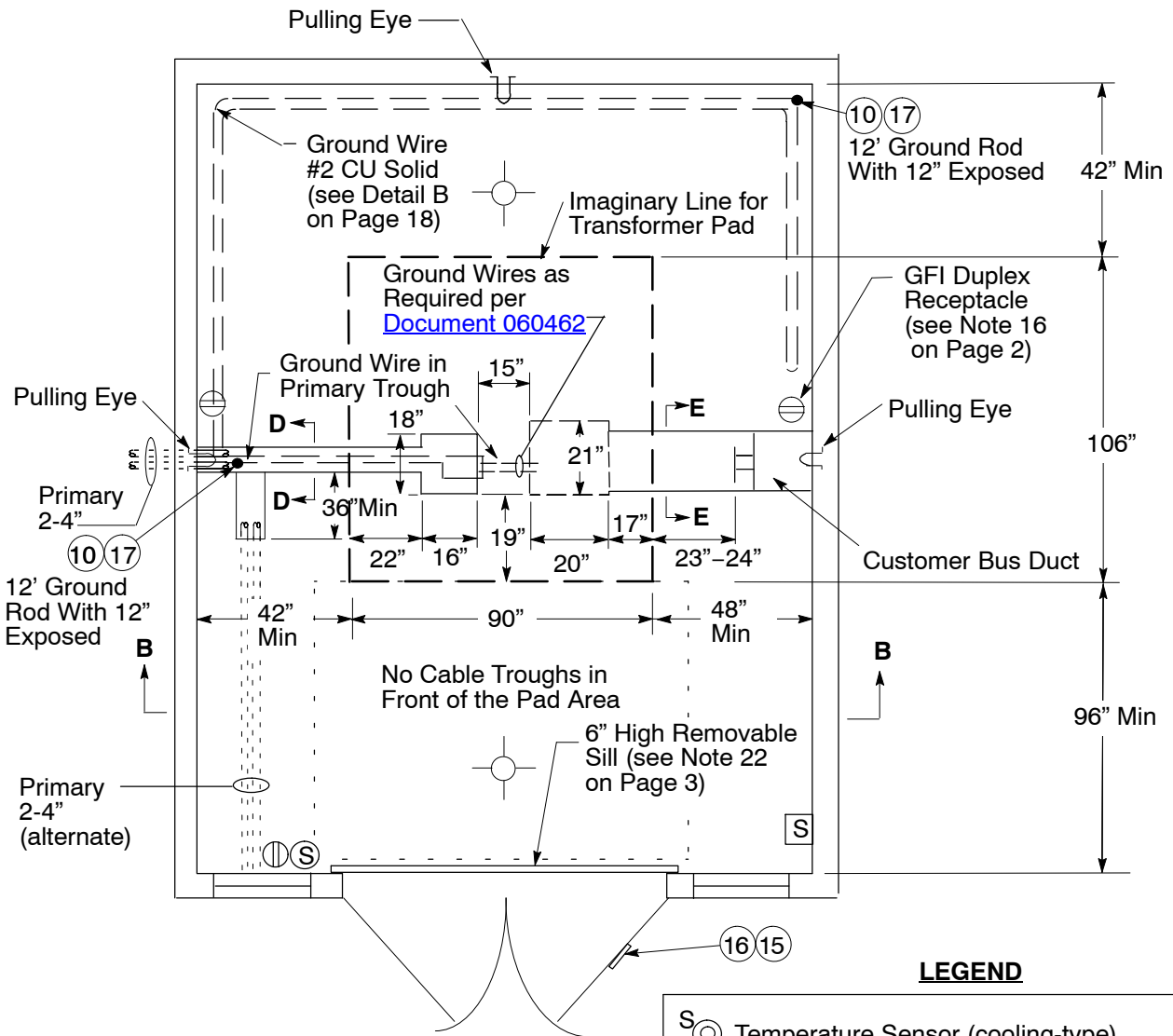

Figure 7
Dry Vault - Plan View
Bus Duct Main Service

LEGEND

	Temperature Sensor (cooling-type)
	Thermostat Control (60" above finished floor)
	Fan Cutoff Switch (60' above finished floor)
	GFI Duplex Receptacles (60" above finished floor)
	Light Switch (60" above finished floor)
	3/4" x 12" Ground Rod
	Light Fixtures
	Pulling Eye (see Note 17 on Page 2)

Note

1. Primary may also be routed to back wall of vault. Primary may not be routed from primary section of transformer to the back wall underneath the transformer.

Layout for Bus Duct with no Separate Fire Pump (continued)

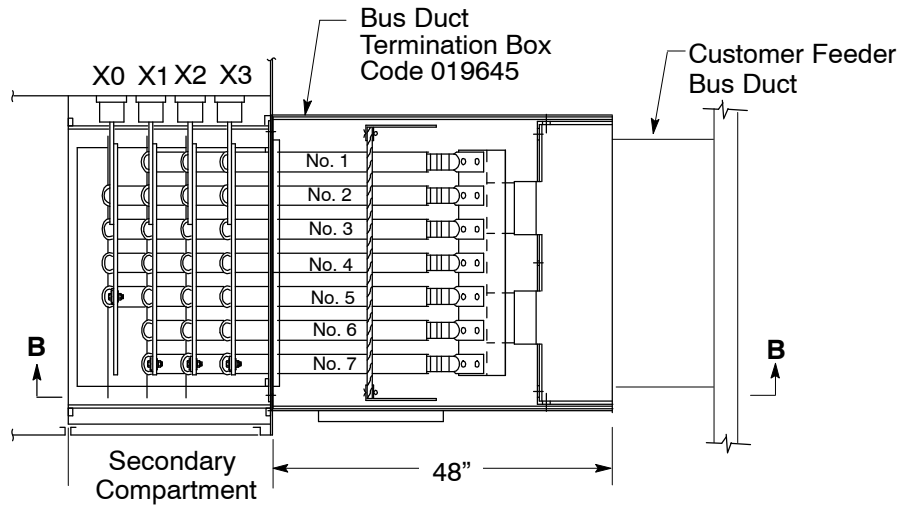

Detail A
Top View - Bus Termination

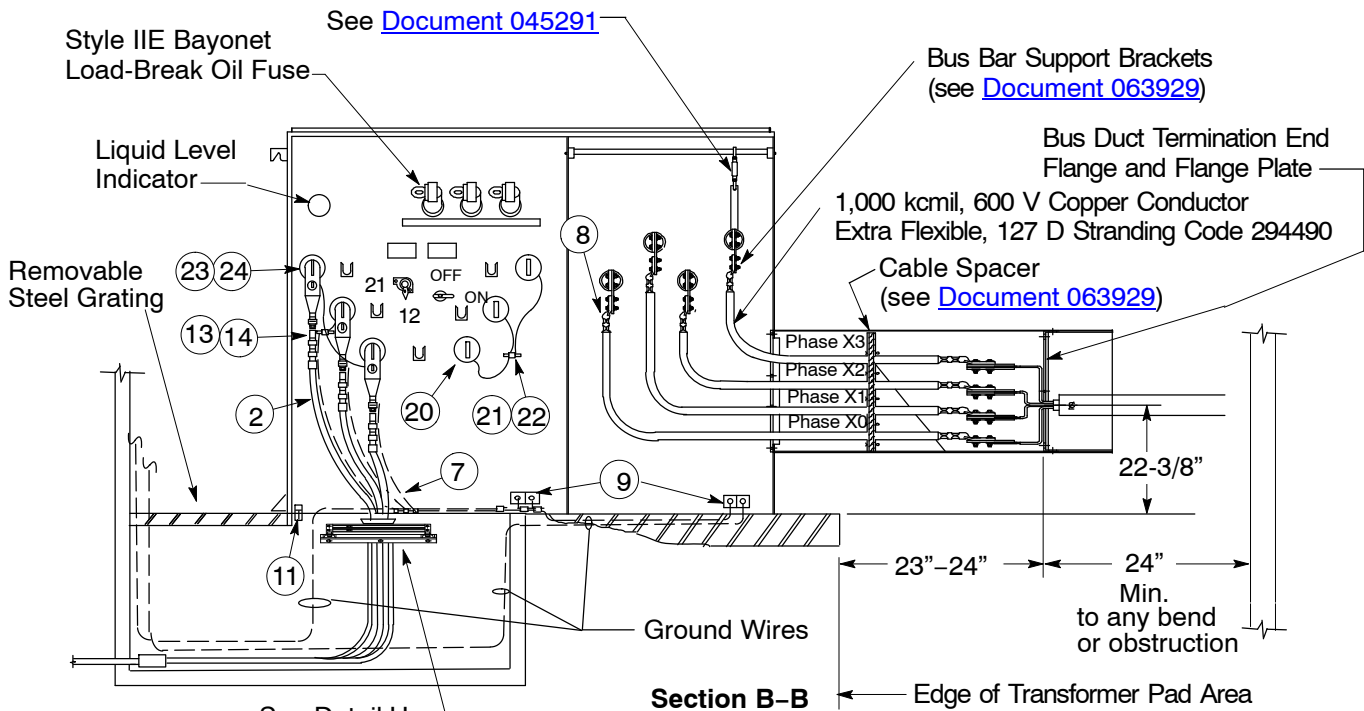

Figure 8
Bus Duct Termination

Note: See [Document 063929](#) for bus duct termination box details

Pad-Mounted Transformer Installed Indoors

Layout for Cable Tray Service with a Separate Fire Pump

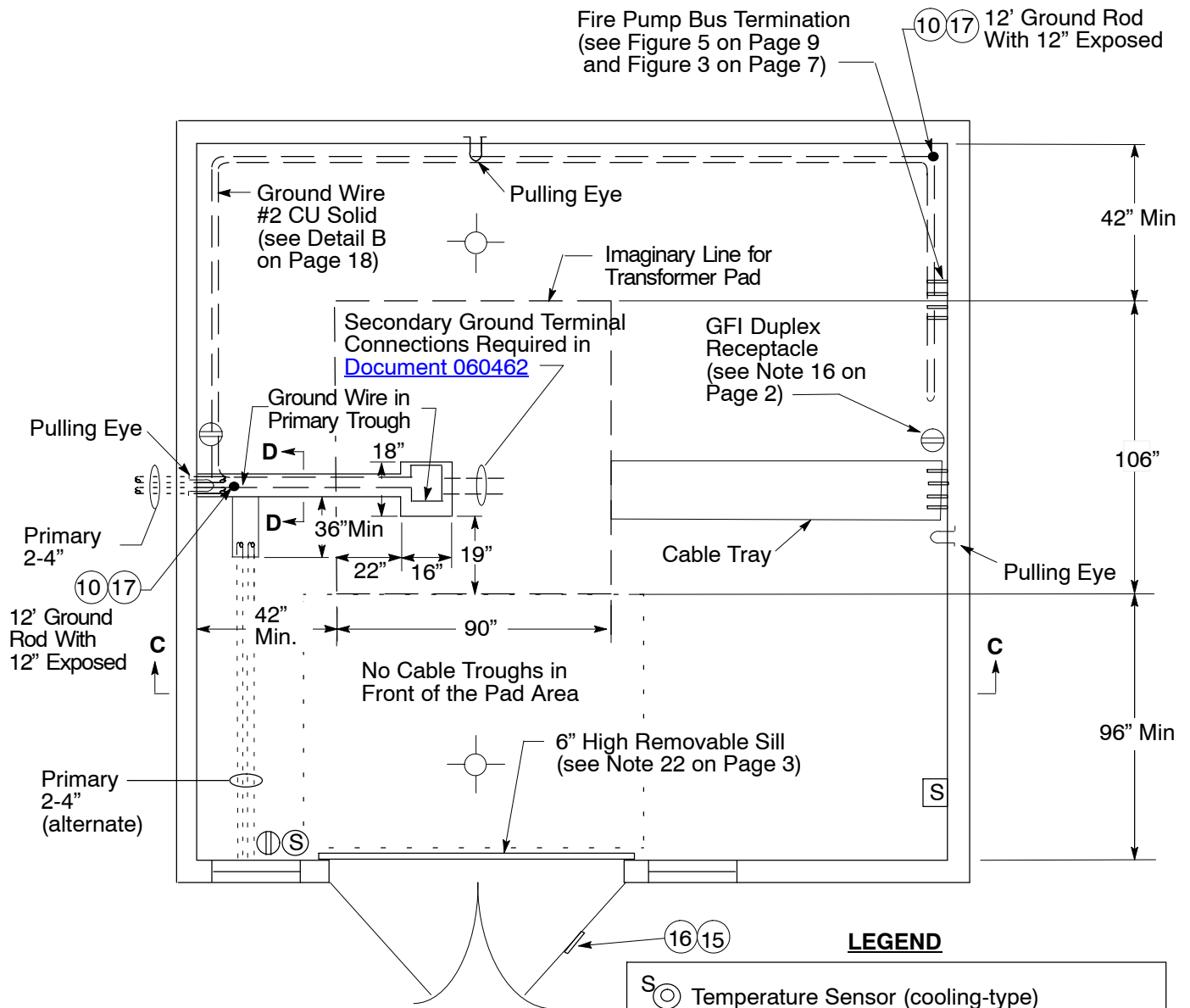

Figure 9
Dry Vault – Plan View
Bus Duct Main Service
With Fire Pump

LEGEND

\odot S	Temperature Sensor (cooling-type)
\odot T	Thermostat Control (60" above finished floor)
\square S	Fan Cutoff Switch (60' above finished floor)
\ominus	GFI Duplex Receptacles (60" above finished floor)
\odot S	Light Switch (60" above finished floor)
•	3/4" x 12" Ground Rod
\odot	Light Fixtures
\cup	Pulling Eye (see Note 17 on Page 2)

Note

1. Primary may also be routed to back wall of vault. Primary may not be routed from primary section of transformer to the back wall underneath the transformer.

Layout for Cable Tray Service with a Separate Fire Pump (continued)

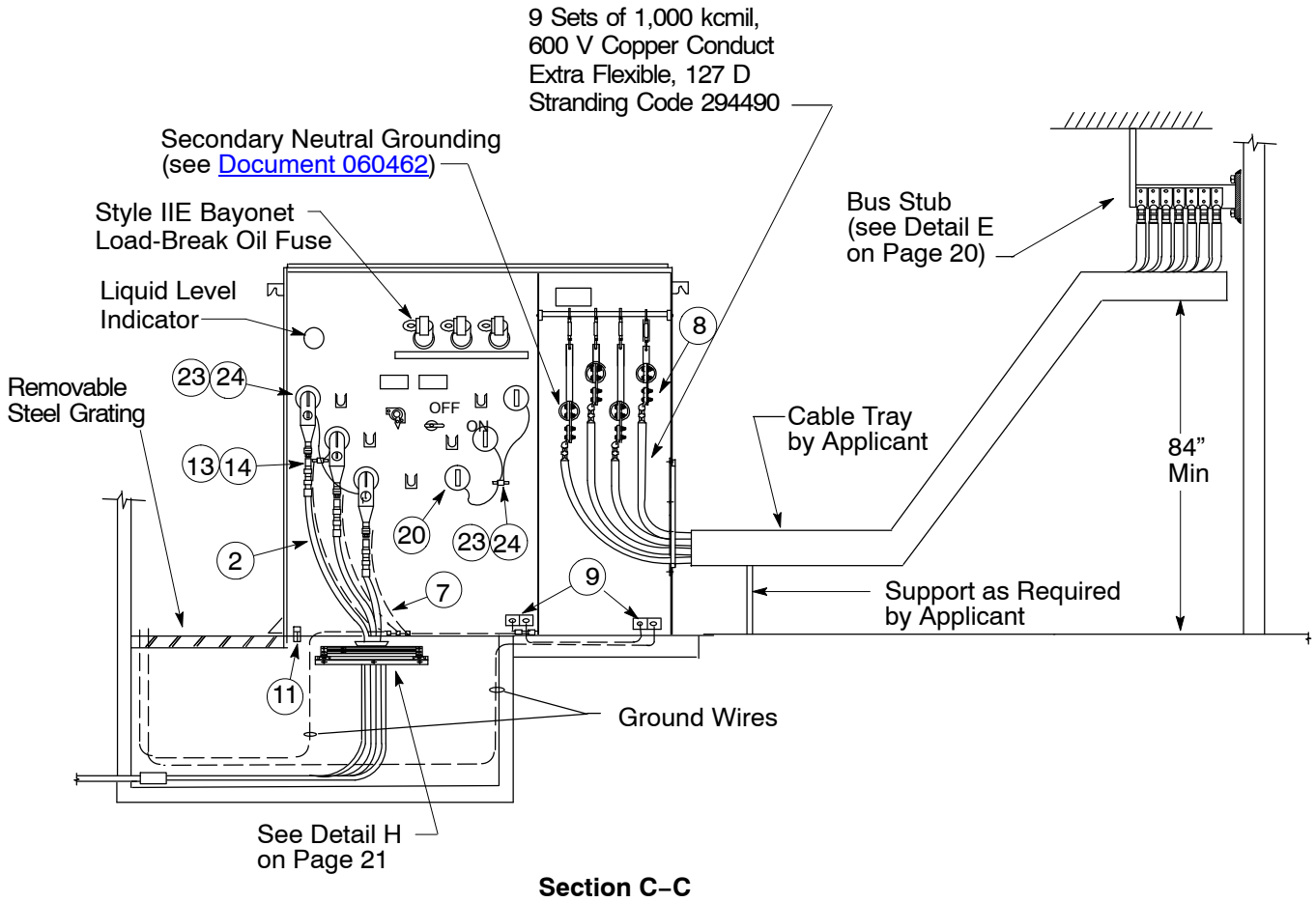

Note: Cable tray shall be vented, with rollers, minimum of 36" wide and 3-1/2" deep.

Figure 10
3,000 A – 4,000 A Pad-Mounted Service Cable Enclosure
With Fire Pump

Pad-Mounted Transformer Installed Indoors

Forced Air Details

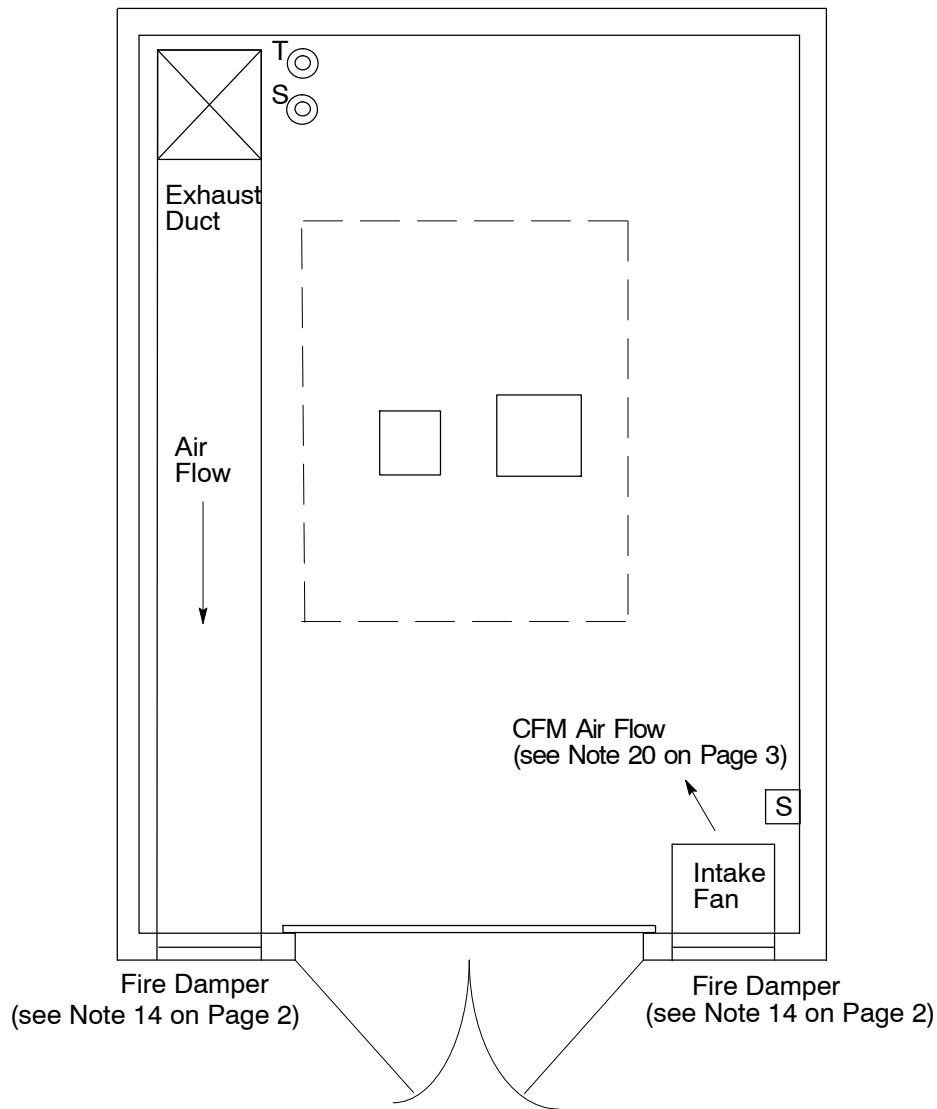

Figure 11
Plan View – Detail of Forced Air Ventilation

Forced Air Details (continued)

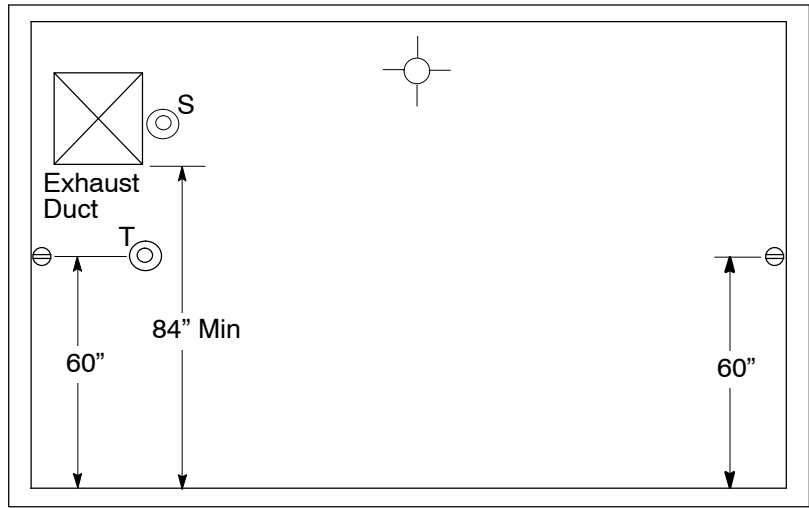

Figure 12
Section A-A

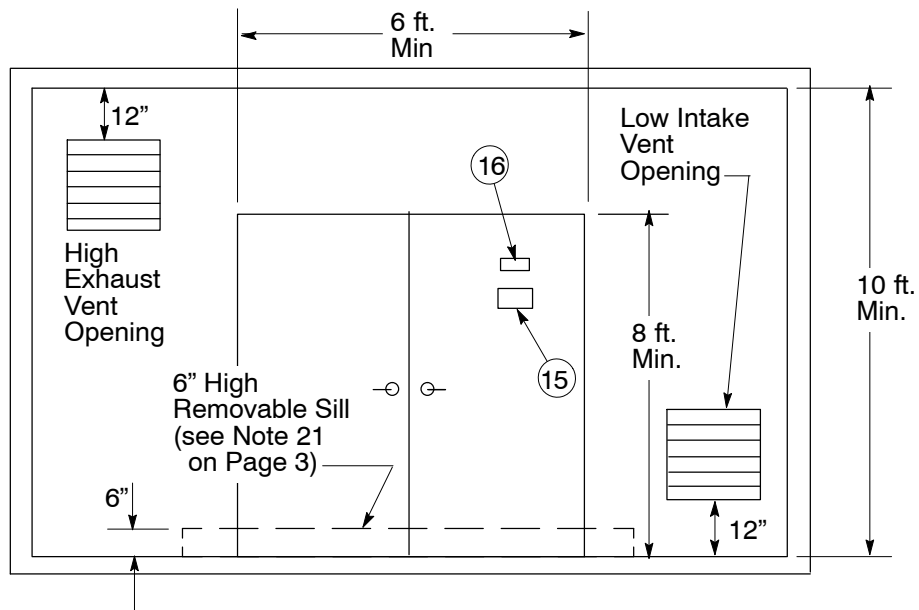

Figure 13
Front View - Ventilation and Entrance Details
When Only Personnel Access is Required

Pad-Mounted Transformer Installed Indoors

Forced Air Details (continued)

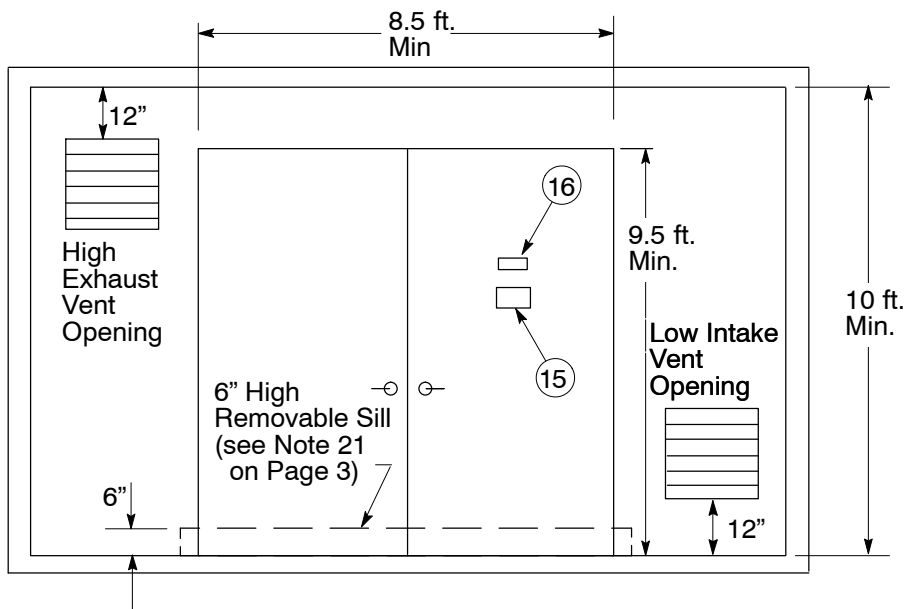
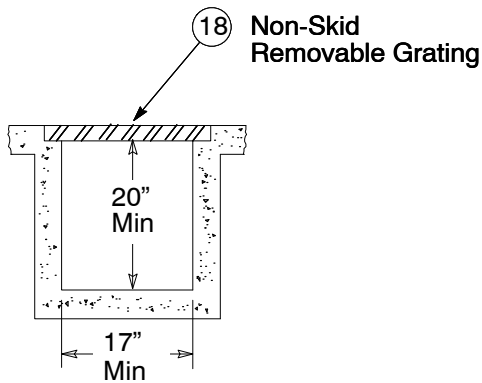

Figure 14
Front View - Ventilation and Entrance Details

Cable Trough Details



Section D-D

**Figure 15
Primary Cable Trough**

Note: 3-hour fire rated
(see Note 14 on Page 2)

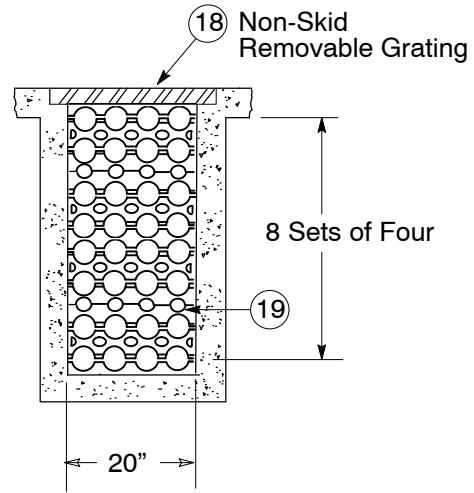

Section E-E

**Figure 16
Secondary Cable Trough for
400 A – 2,500 A Mains**

Note: Size as required to fit duct spacers.
Dimensions shown are for Formex four
way spacer for 2" conduit with 2"
separation (see Detail C on Page 19).

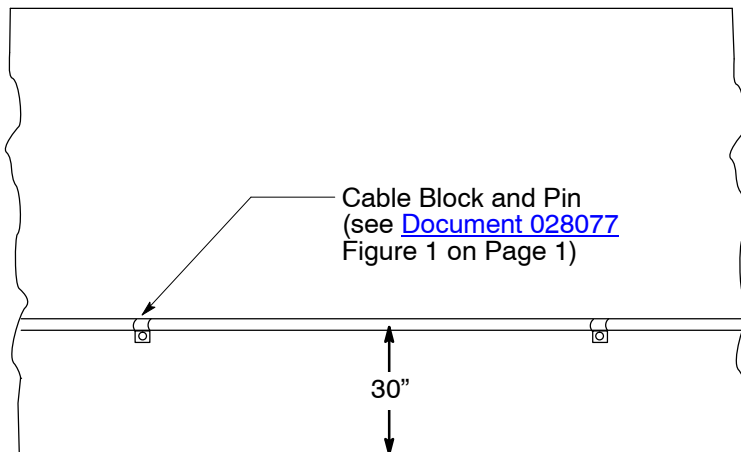

**Detail B
Mounting Ground Ring Bus
to Vault Wall**

Pad-Mounted Transformer Installed Indoors

Cable Trough Details (continued)

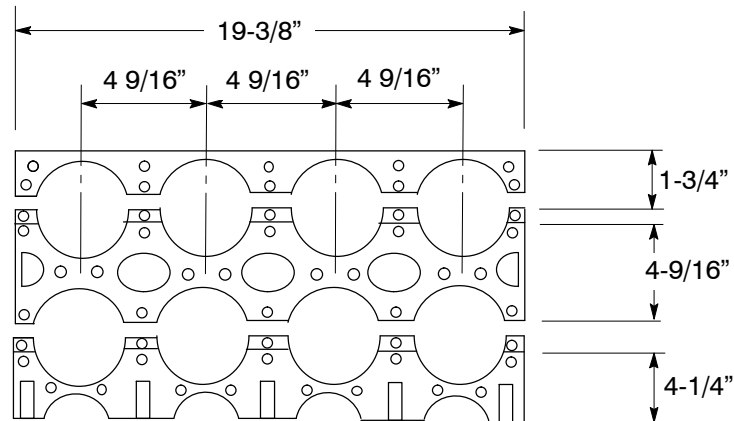

Detail C
Formex Four-Way Duct Spacer 2" Duct With 2" Separation

1. Place one duct spacer every 18" from secondary window edge.
2. Functional equivalent may be used.
3. Use one 4-hole spacer with 2" holes for each set of 1000MCM cables, for example:
 - for five sets of cables each spacer set is 4 holes wide by 5 layers deep.
 - for seven sets of cables each spacer set is 4 holes wide by 7 layers deep.

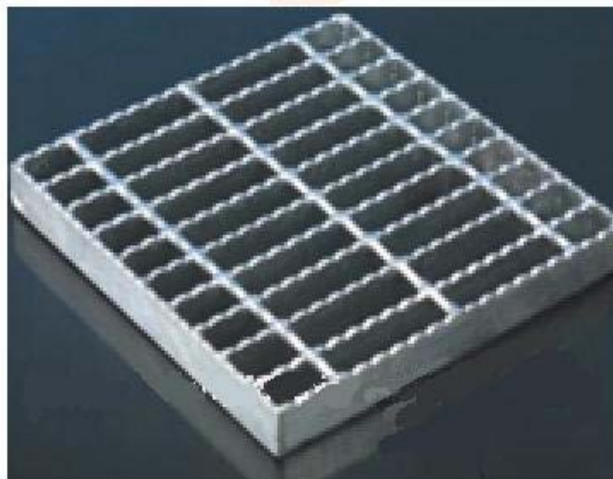

Detail D
Typical Non-Skid Grating

1. Size and numbers as required.
2. Maximum weight of each piece shall not exceed 50 lbs.
3. Open area must be at least 45%.

Bus Bar Termination Details

1. All exposed grounded metal bolts within 10" of bus bars shall be suitably insulated.
2. Barrier is not needed if firestop supports the bus and is smokeproof.

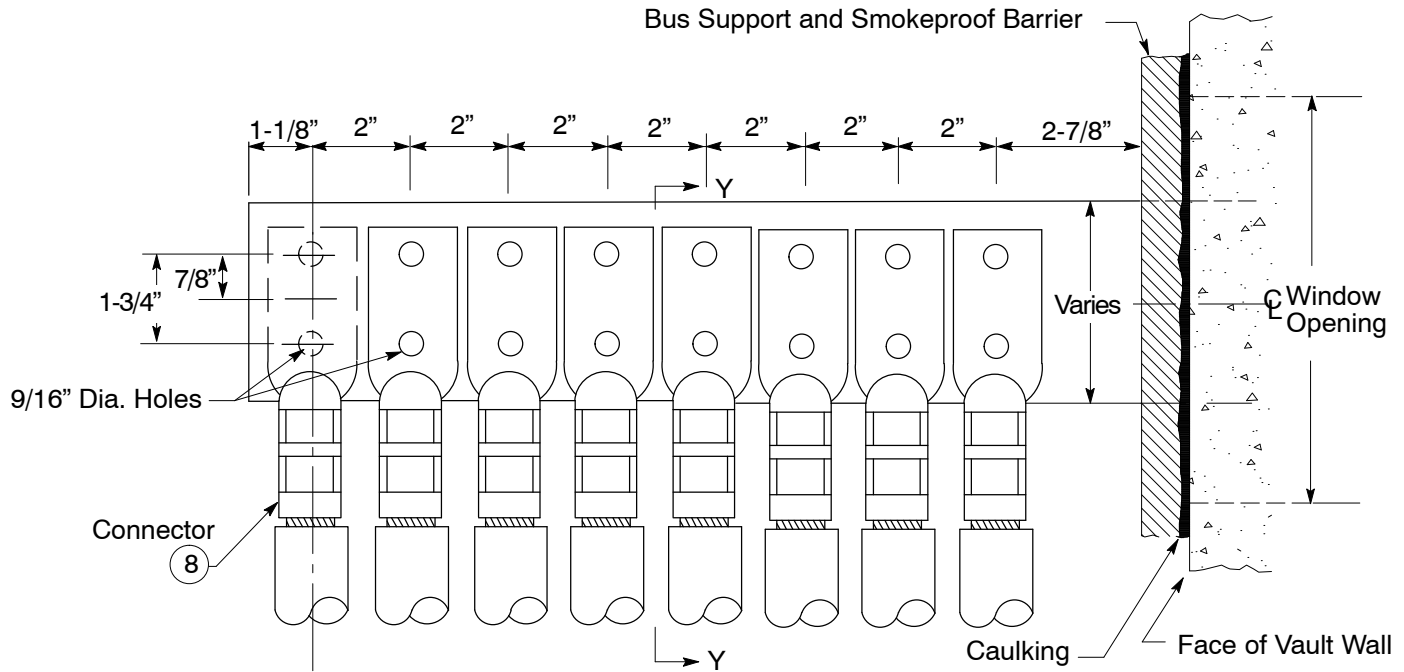

Detail E
Connection to Customer's Bus Bar

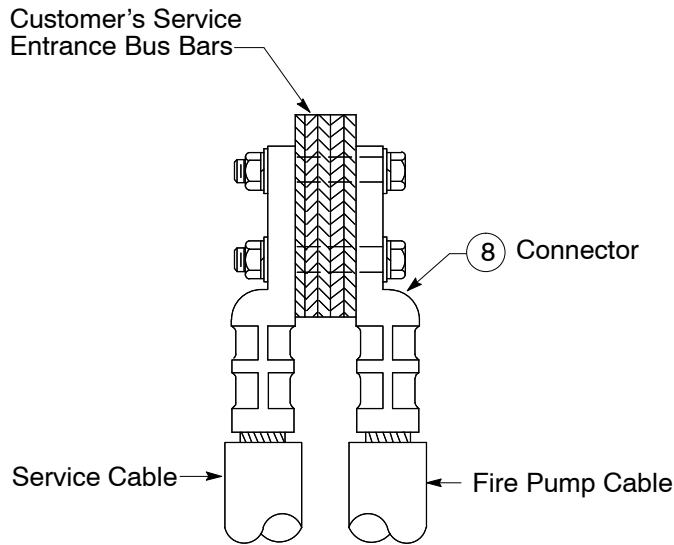

Detail F
Section Y-Y

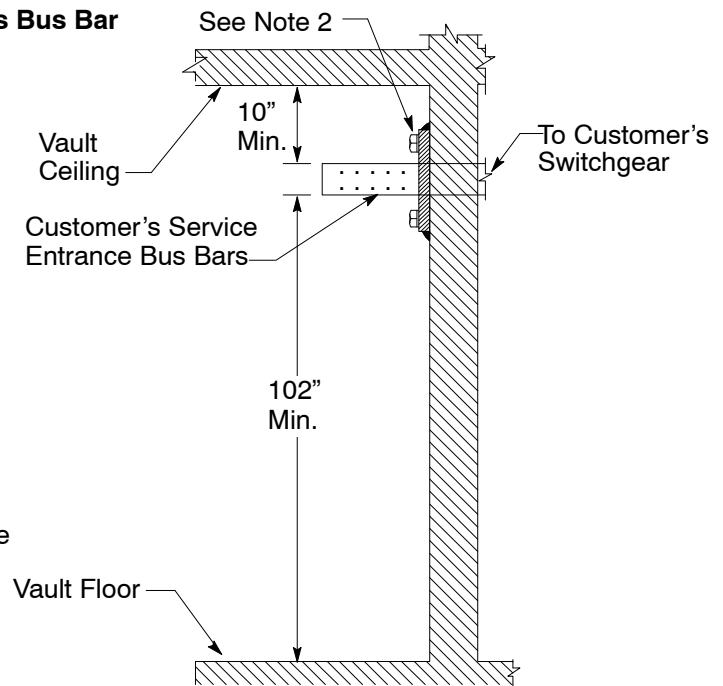

Detail G

Pad-Mounted Transformer Installed Indoors

Primary Cable Support Details (continued)

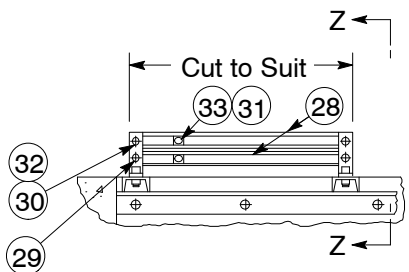

Detail H
Cable Termination Support

Table 2 Primary Cable Termination Support

Item	Quantity	Description
25	-	Bolt, Machine 1/2" x 4", Square Head, Galvanized
26	-	Bolt, Machine, 1/2" x 1-1/4" Hexagonal, Head, Galvanized
27	-	Bolt, Machine, 3/8" x 1" Hexagonal, Head, Galvanized
28	2	Channel, 1-1/4", Unistrut A-1000
29	2	90° Angle Fitting, 3/16", Unistrut A-1326
30	4	Spring Nut, 3/8", Unistrut A-1008
31	12	Spring Nut, 1/4", Unistrut A-1006-1420
32	4	Capscrew, Hexagonal Head 3/8" x 1" Galvanized
33	12	Capscrew, Hexagonal Head 1/4" x 1" Galvanized

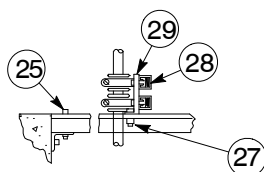

Section Z-Z
Support Mounted Above Floor Surfaces
(all mounting holes, drill to suit)

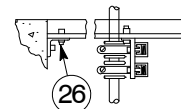

Alternate Section Z-Z
Support Mounted Below Floor Surface

Revision Notes

Revision 11 has the following changes:

1. Removed Figure 15 and Notes 1, 2 and 3 on Page on18.

