	CONCRETE PAD FOR THREE-PHASE, LOOP-STYLE, PAD-MOUNTED TRANSFORMERS		045292
	Asset Type: Electric Distribution	Function: Design	
Issued by: Connie Pascua (CZP1) <i>Connie Pascua</i>	Date: 04-15-09		
Rev. #12: This document replaces PG&E Document 045292, Rev. #11. For a description of the changes, see Page 8.			

This document is also included in the following manual:

- *Electric and Gas Service Requirements Manual (Greenbook)*

Purpose and Scope

This document shows construction details for concrete pads for three-phase, loop-style, pad-mounted transformers. Refer to Document 043817 for installation details of three-phase, radial-style, pad-mounted transformers. See Document 045290 and Document 045291 for fabrication and installation details of three-phase, loop-style, pad-mounted transformers.

General Information

1. When a pad is installed by the customer, that customer shall provide all materials. In areas of known unusually soft soil conditions, PG&E will require special treatment as specified in Notes 12, 13, and 14. Before pouring or setting the pad, the customer or contractor will request an inspection by PG&E to approve the installation. PG&E shall determine the acceptability of each pad installation.
2. The installation of the pad includes the two ground rods and the interconnecting ground wire.

Application

3. If a pad-mounted transformer cannot be located away from vehicular traffic, the customer shall provide suitable barriers for the protection of the transformer. PG&E shall determine the protection requirements according to Document 051122.
4. If the customer is to use bus duct, the secondary opening is not needed. Grout in the window of precast pads.
5. The pad sizes are based on maximum dimensions, including cooling radiators, of the various manufacturers' transformers.
6. The Style IIE transformers will fit on Style IIB/IIC/IIF pads. The 75 kVA, Style IIE transformer will fit on the largest Style IIE pad. The 300 kVA, Style IIE transformer will fit on the small Style IIE pad. The 2,500 kVA, Style IIE transformer will sit on the old 80" x 106" pad, but the radiators will overhang the pad. (Note: Some 1989 and 1999 Style IIE transformers have radiators that will overhang the pad.)
7. The Style IIG will fit on the largest IIE pad.
8. The Style IIH will fit on the largest IIC/IIF pad.

Construction Notes

9. In general, all equipment pads should be installed as level as practical. Pads supporting oil-filled equipment must be leveled to within 1 inch in 8 feet in all directions.
10. The transformer pad shall be placed on firm, compacted native material or on engineered fill which has been compacted at least to the requirements of Note 13.
11. The area under the pad shall be excavated to the required grade, or to a depth necessary to reach firm, undisturbed material, whichever is deeper. The material can be considered firm if it cannot be penetrated by thumb except with moderate effort.
12. If firm material has not been reached within a depth of 3 feet, excavate 3 feet beyond the perimeter of the pad and backfill the entire excavated area to the required grade and to the requirements of Note 13.
13. In case it has been necessary to excavate deeper than the required grade to reach firm material, backfill to the required grade in one of the following ways:

Concrete Pad for Three-Phase, Loop-Style, Pad-Mounted Transformers

- A. Backfill with clean, non-expansive soil compacted to 90% of maximum density. Soil shall be placed in layers not more than 8 inches thick before compaction. Maximum density and in-place density is to be determined by [California Test Method No. 216-G, Part I and II](#) respectively, or by [ASTM D-1556](#) and [ASTM D-1557](#) respectively. A copy of the test results may be required by PG&E.
 - B. Backfill with soil-cement slurry consisting of one sack of Portland cement per cubic yard and clean native soil or sand. When slurry is used as a backfill material, the customer will not be required to use a poured-in-place pad.
- 14. In areas of known soft soil conditions, trenches within the pad excavation area for the installation of conduits shall be backfilled in one of the ways specified in Note 13 on Page 1.
 - 15. In addition to the above, precast pads shall be placed on a 3-inch layer of slurry backfill or sand screeded level to provide uniform bearing.
 - 16. Conduit windows shall be grouted with non-shrink grout (asphalt or blacktop is not approved for grouting).
 - 17. Concrete shall be designed to attain a strength of 2,500 pounds per square inch (psi) at 28 days. Slump for concrete placement shall not exceed 3 inches. Reinforcing steel shall be per [ASTM A615](#), Grade 40 minimum.
 - 18. A minimum distance of 6 feet shall be maintained between ground rods.
 - 19. Wood-float or light broom finish the top of the slab. Finish all exposed edges with a finishing tool. Vertical edges shall have a 3/4-inch chamfer. Slope exposed horizontal surfaces slightly for drainage. Moist-cure concrete for at least 7 days after pouring. Do not install transformer until 14 days after pouring concrete. See Note 20 for exceptions to this requirement.
 - 20. The transformer may be installed earlier than the 14 days specified above, provided the concrete has attained a compressive strength of at least 1,500 psi obtained as follows (this procedure is permitted only for urgent cases where earlier pouring of pad is not practical):
 - A. For a six-sack mix using normal Portland cement, the transformer may be installed after 7 days; or for a six-sack mix using high early-strength cement, the transformer may be installed after 72 hours.
 - B. All concrete must be moist-cured to the minimum period specified above before installing the transformer.
 - C. Verify the required strength by either concrete cylinder test or Schmidt hammer test.
 - 21. Belled ends of conduits should be placed approximately 1 inch above the concrete pad surface. If belled ends are removed, install end bell fittings. Temporarily plug or cap all conduits.
 - 22. Only PG&E-approved utility electric-service-related equipment and structures may be installed in the area beneath the transformer pad. The area 6 feet deep and 12 inches horizontally around the pad shall be free of all foreign substructures.

Construction Notes for Precast Pads

- 23. Concrete shall be designed to attain a strength of 2,500 psi in 28 days.
- 24. Inserts and securing of inserts shall be of sufficient strength to lift the pad. A minimum of three inserts with 7/8-inch diameter, UNC thread and 2-1/4 inch inside depth, steel, galvanized with temporary plugs shall be provided.
- 25. Inserts shall be installed flush with the surface of the pad.
- 26. Reinforcing bars shall be as per [ASTM A615](#), Grade 40 minimum.
- 27. All exposed edges shall have a 3/4-inch chamfer or radius.
- 28. Surface shall have a light broom or wood-float finish.
- 29. The surface of the pad shall be level and flat.
- 30. Precast pads shall be permanently identified with manufacturer's name (for location see Figure 4 and Figure 5 on Pages 7 and 8) and have the weight stenciled on top of the pad.

**Concrete Pad for Three-Phase, Loop-Style,
Pad-Mounted Transformers**

References	Location	Document
Corrosion Resistant Ground Rods and Ground Rod Clamps	UG-1: Connectors/Greenbook	013109
<u>Installation of Three-Phase, Radial-Style, Pad-Mounted Transformers</u>	UG-1: Transformers	043817
<u>Loop-Style, Three-Phase, Pad Mounted Transformers</u>	UG-1: Transformers	045290
<u>Installation of Loop-Style, Three-Phase, Pad-Mounted Transformers</u>	UG-1:Transformers	045291
<u>Location, Clearances, and Mechanical Protection</u>		
Details for Pad-Mounted and Subsurface Equipment	UG-1: General	051122
Underground Conduits	UG-1: Conduits	062288

Concrete Pad for Three-Phase, Loop-Style, Pad-Mounted Transformers

Table 1 Bill of Materials for Concrete Transformer Pads

Item	Quantity	Description	Code	Document
1	1	Pad, Concrete, Reinforced (see Page 5)	-	-
2	As Required	Wire, #2 AWG, Solid, Soft Drawn, Bare Copper ¹	290074	-
3	2	Ground Rod, 5/8" x 8', Copperclad	187013	013109
4	2	Clamp, Ground Rod, for Item 3	187012	
5	As Required	Conduit, Type and Size (as required)	-	062288
6	As Required	Reinforcing Steel, Number 4 ²	-	-
7	As Required	Compacted Backfill	-	-
8	Tool	Bolt, Eye, 7/8" Diameter x 1-1/2" Long, 1-1/2" Inside Diameter, Shoulder-Type	190013	-

¹ When pad is installed for PG&E by others, the use of solid or stranded wire is acceptable.

² Number 3 rebar at 12-inch maximum separation with 4x4 6-6 wire mesh over the entire surface may be substituted for the use of Number 4 rebar.

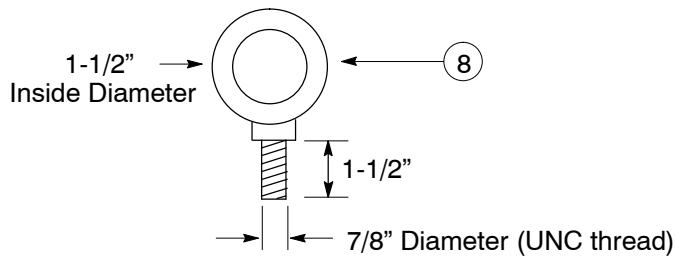

Detail A
Lifting Eye for Pad and Boxes

Concrete Pad for Three-Phase, Loop-Style, Pad-Mounted Transformers

Pad Arrangements for Style IIA, IIB, IIC, IIF, and IIH Transformers

Notes

1. Primary conduits must be centered in the window.
2. Secondary conduits shall be grouped towards the front of the pad.
3. Precast pads do not have cut off walls.
4. A 6-foot minimum separation shall be maintained between ground rods.
5. The ground wire must be a continuous wire that runs from the outside ground rod, under the pad, to the primary window, then above the pad from the primary window, through the secondary window, to the secondary ground rod as shown below.

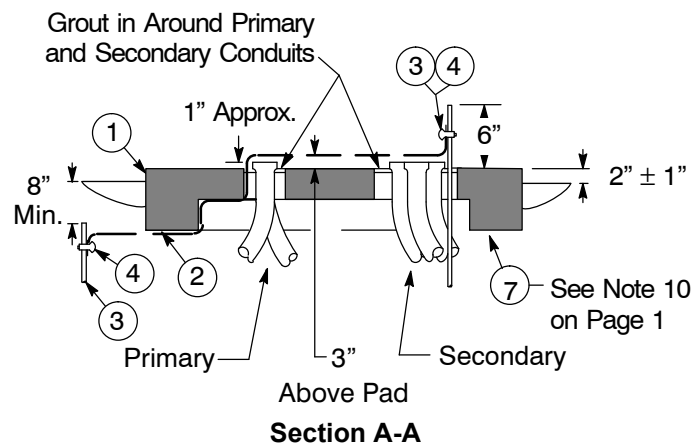
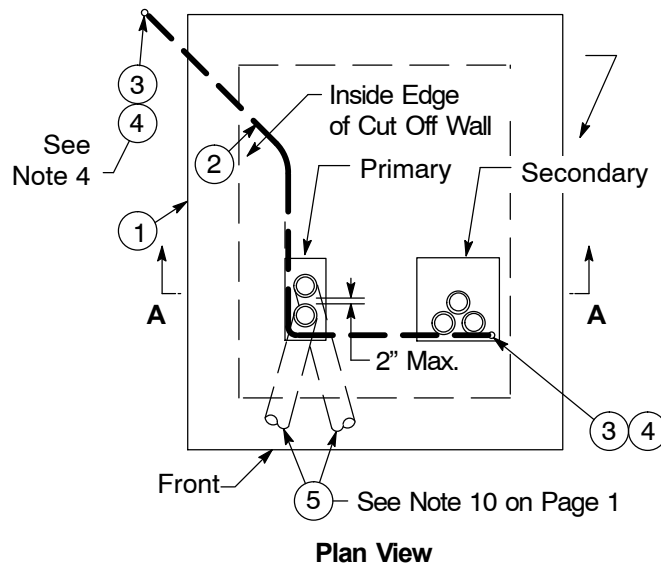
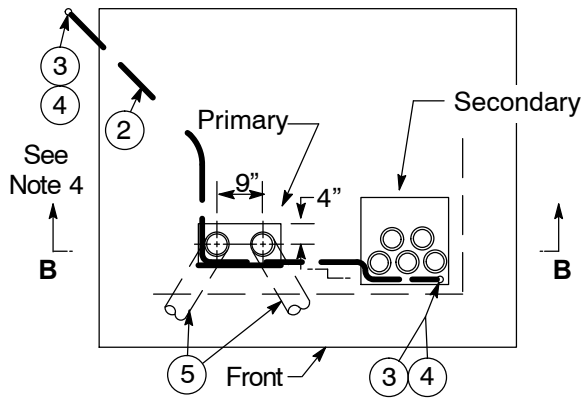

Figure 1
Style IIA, IIB, IIC, IIF, and IIH Pad Arrangement,
Poured-in-Place Pad Shown

Pad Arrangements for Style IID, IIE, and IIG Transformers

Notes

1. Install primary conduits as shown. Keep single primary conduit installation to the left as indicated to reduce strain on elbow terminators.
2. Secondary conduits shall be grouped towards the front of the pad.
3. Precast pads do not have cut off walls.
4. A 6-foot minimum separation shall be maintained between ground rods.
5. The ground wire must be a continuous wire that runs from the outside ground rod, under the pad, to the primary window, then above the pad from the primary window, through the secondary window, to the secondary ground rod as shown below.



Plan View

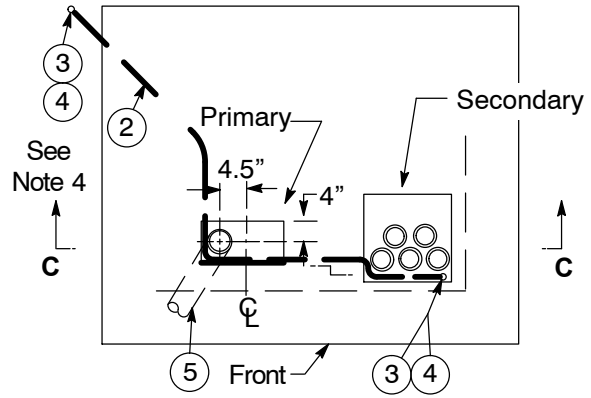

Plan View

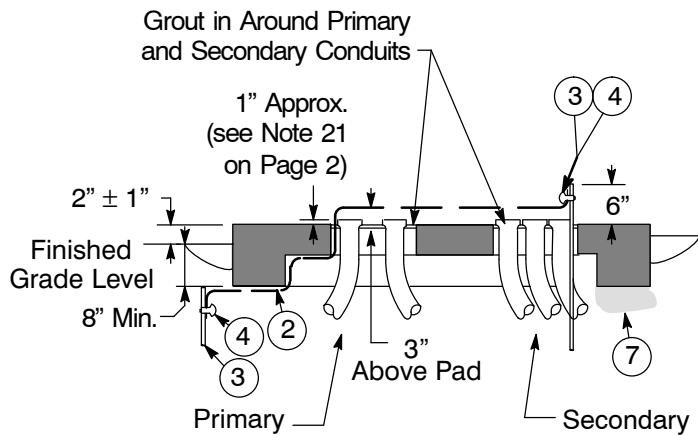

Section B-B

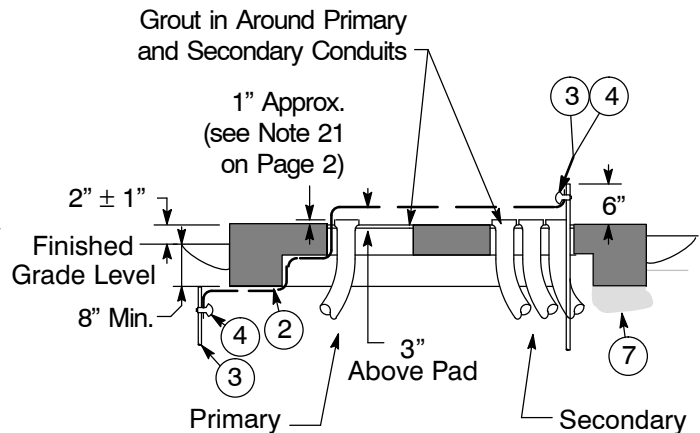

Section C-C

Figure 2
Loop Installation of Style IID, IIE, and IIG Pad Arrangement, Poured-in-Place Pad Shown

Figure 3
Radial Installation of Style IID, IIE, and IIG Pad Arrangement, Poured-in-Place Pad Shown

Concrete Pad for Three-Phase, Loop-Style,
Pad-Mounted Transformers

Concrete Pad Details for Style IIA, IIB, IIC, IIF, and IIH Transformers

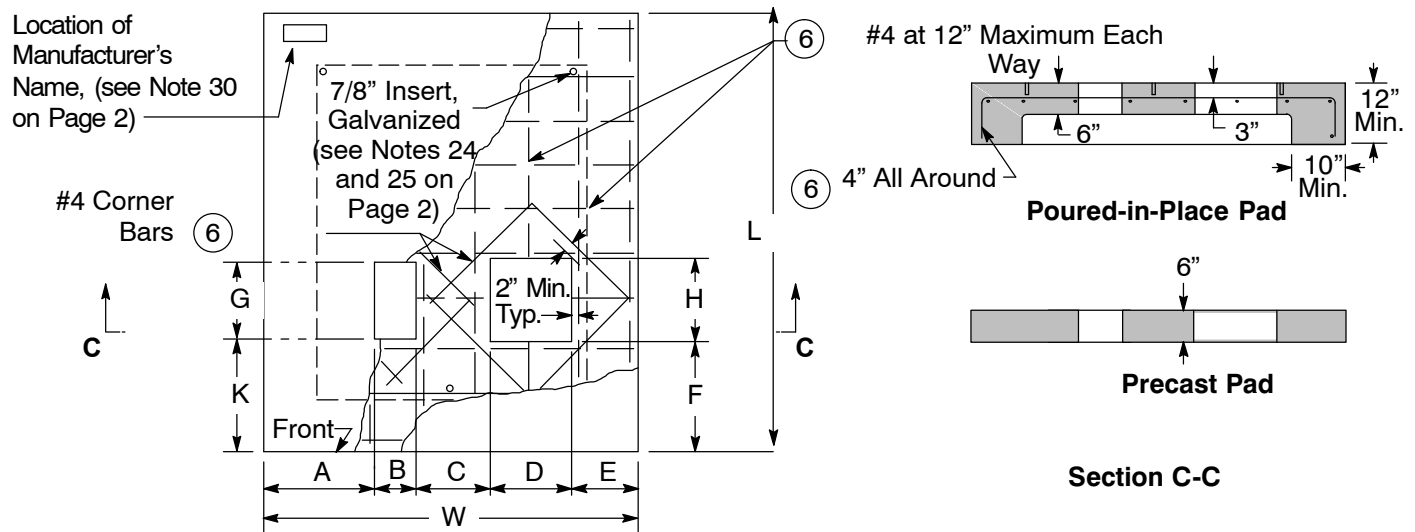

Figure 4
Construction Details of Style II A/B/C/F/H Pad
(see Figure 1 on Page 5 for pad arrangement)

Table 2 Dimensions and Codes for Style IIA, IIB, IIC, IIF, and IIH Transformer Pads ¹

Transformer			Pad Dimensions (inches)											Code			
Style	kVA Size	Approximate Maximum Weight (lbs)	A	B	C	D	E	F	G	H	K	L	W				
IIA	75	3,200	21	8	14	16	13	15	16	16	15	72	72	043436			
	(112.5) ²	3,200															
	150	3,500															
	(225) ²	4,000															
	300	4,500															
IIB and IIF	(225) ²	4,500	23	8	19	17	13	15	16	19	15	78	80	043538			
	300	5,000					23										
	(500) ²	6,000	29				23								100	96	040242
	750	9,000	32				22								112	98	040243
	1,000	11,000	36	26	117	106	040244										
IIC and IIF	1,500	13,000	31	8	23	17	26	15	16	19	15	120	105	040245			
	(2,000) ²	15,000															
IIC and IIF	2,500	16,000															
IIH	2955/ 3325	22,000															

¹ See Document 066211 for approved suppliers.

² () = Indicates a kVA size that is no longer purchased.

Concrete Pad for Three-Phase, Loop-Style,
Pad-Mounted Transformers

Concrete Pad Details for Style IID, IIE, and IIG Transformers

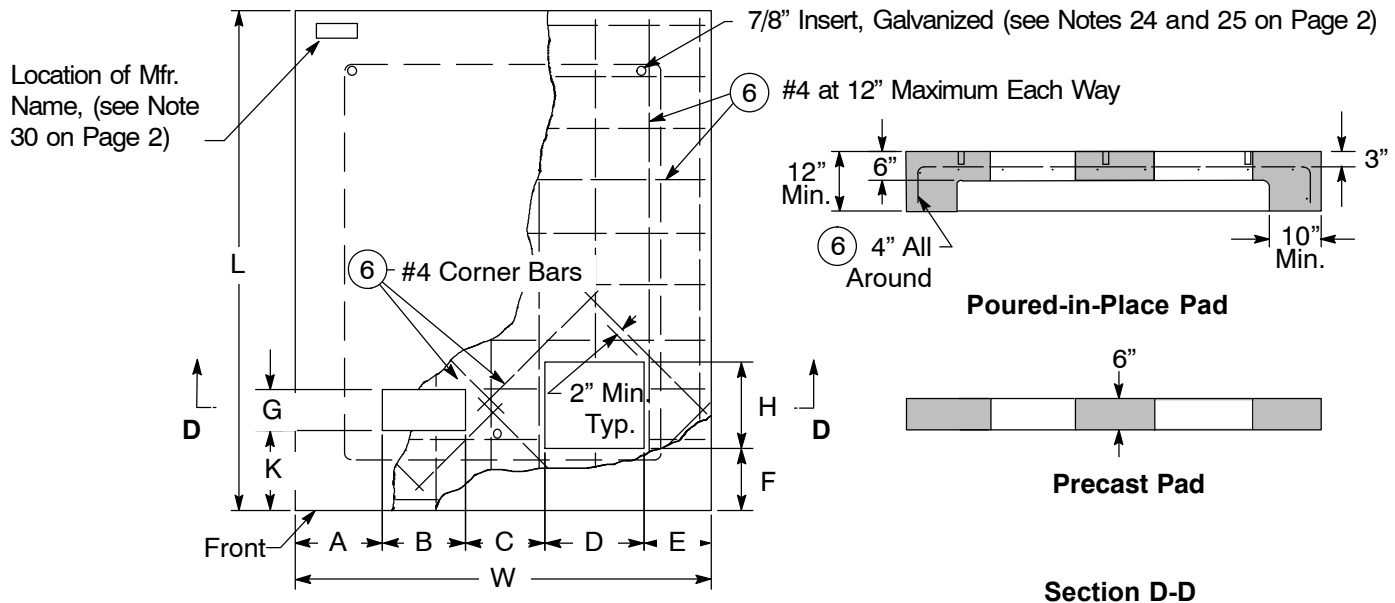

Figure 5
Construction Details of Style IID, IIE, IIG Pad
(see Figure 2 on Page 6 for pad arrangement)

Table 3 Dimensions and Codes for Style IID, IIE, and IIG Transformer Pads ¹

Transformer			Pad Dimensions (inches)										Code	
Style	kVA Size	Approximate Maximum Weight (lbs)	A	B	C	D	E	F	G	H	K	L		W
IID and IIE	75	4,600	17	16	15	19	13	10	6	17	14	61	80	040291
	(112.5) ²	4,800												
	150	5,000												
IIE	(225) ²	5,500	22	16	15	20	17	20	6	19	25	106	90	040292
	300	5,800												
	(500) ²	6,100												
	750	9,000												
IIE	1,000	11,000	22	16	15	20	17	20	6	19	25	106	90	040292
	1,500	13,000												
IIE	2,500	16,000	22	16	15	20	17	20	6	19	25	106	90	040292
IIG	2955/3325	22,000	22	16	15	20	17	20	6	19	25	106	90	040292

¹ See Document 066211 for approved suppliers.

² () = Indicates a kVA size that is no longer purchased.

Revision Notes

Revision 12 has the following changes:

1. Added Notes 7 and 8 to Application notes on Page 1.
2. Added Transformer IIH to Pad Arrangements on Page 5.
3. Added Transformer IIG to Pad Arrangements on Page 6.
4. Added Transformer IIH to Concrete Pad Details and revised Table 2 on Page 7.
5. Added Transformer IIG to Concrete Pad Details and revised Table 3 on Page 8.