

Infrared (IR) Inspections of Electric Distribution Facilities

SUMMARY

This utility procedure describes the requirements for performing infrared (IR) inspections (i.e., thermography) on overhead (OH) and underground (UG) electric distribution facilities, excluding substations.

This procedure serves the following purposes:

- Explains the permitted use of nonutility-grade IR cameras by restoration employees and other employees who are infrequent users
- Defines roles and responsibilities for employees who perform IR inspections

Level of Use: Informational Use

TARGET AUDIENCE

This procedure applies to the following PG&E employees:

- Compliance
- Electric Distribution Asset Strategy
- Electric Distribution Planning and Operations
- Electric Maintenance and Construction (M&C)
- Power Quality
- Project Delivery
- Restoration and Control
- Service Planning and Design (SP&D)

SAFETY

Personal protective equipment (PPE) must always be worn when performing IR inspections. This includes, but is not limited to, hard hats, safety glasses, and suitable footwear.

BEFORE YOU START

USE standard-issue PPE identified in any associated trainings and job aids.

FOLLOW standard safe work practices by referring to [AVI-4001M, Uncrewed Aircraft Systems \(UAS\) Operations Manual](#).

USE the appropriate IR camera.

Infrared (IR) Inspections of Electric Distribution Facilities

TABLE OF CONTENTS

SECTION	TITLE	PAGE
1	General Information	2
2	Requirements and Recommendations	3
3	Setting Up the IR Camera.....	9

PROCEDURE STEPS

1 General Information

1.1 Compliance inspectors and external contractors CONDUCT IR inspections on electric distribution facilities.

1. Depending on the specific job, restoration employees, contractors, and occasional users may be required to perform the actions outlined in this procedure.

1.2 Background

NOTES

- According to industry specifications, connectors should operate at lower temperatures compared to their corresponding conductors.
- When the connector’s temperature exceeds its respective conductor, it causes a higher-resistance connection and an increased risk of failure. The exact prediction of failure remains uncertain.
- The connector degradation accelerates with heightened loads or temperatures.

1. USE IR imaging and temperature-measuring systems as diagnostic tools during electric distribution system inspections and within preventive maintenance initiatives.
2. USE IR imaging at primary, secondary, and service distribution levels because it enables precise detection of malfunctioning devices, equipment, and components, which facilitates timely repair or replacement actions.
3. Conductor manufacturers recommend **limiting** the maximum operating temperature for tensioned, bare conductors to 75 degrees (°) Celsius (C) or 167 degrees (°) Fahrenheit (F).
4. Conductor manufacturers recommend **limiting** the maximum operating temperature for insulated conductor to the following temperatures:
 - a. 75°C or 167°F for high molecular weight polyethylene (HMWPE) material

Infrared (IR) Inspections of Electric Distribution Facilities

1.2 (continued)

- b. 90°C or 94°F for cross-linked polyethylene (XLPE) material
- c. 105°C or 221°F for ethylene propylene rubber (EPR) material

1.3 Equipment

NOTES

- The IR camera uses an image-scanning technique to specifically identify heat radiating from a target and the target's background. These units capture and visually store thermal images for immediate or future evaluation.
- Using IR camera units, the operator can pinpoint the hottest spot on the observed target.

1. USE IR imaging systems to detect and record all heat emissions within the system's field of view.
2. USE either utility-grade or nonutility-grade IR cameras as tools to assist in troubleshooting facilities or equipment known to have power-quality issues.
3. WHEN performing IR inspections,
USE only a utility-grade IR camera.
4. WHEN troubleshooting or performing work verifications,
USE only a nonutility-grade IR camera to identify hot spot connections or equipment.

2 Requirements and Recommendations

2.1 Implementation

NOTE

This IR procedure serves as a crucial component of a preventive maintenance program.

1. The recommended maintenance priorities outlined in [Subsection 2.4](#) on Page 5, [Table 1, "Corrective Maintenance Priorities for Overhead Distribution Facilities,"](#) on Page 7, and [Table 2, "Corrective Maintenance Priorities for Underground Distribution Facilities,"](#) on Page 8, accomplish the following:
 - a. Reduce the risk of component failures.
 - b. Prevent further facility damage.

Infrared (IR) Inspections of Electric Distribution Facilities

2.1 (continued)

- c. Facilitate a proactive approach to repairing or replacing components identified as “abnormal.”

2.2 Equipment Specifications

1. PERFORM the following actions when reviewing equipment specifications:
 - a. ENSURE that the video-imaging equipment that uses IR technology to inspect UG electric distribution facilities meets the following specifications:
 - (1) The system must be sealed.
 - (2) The equipment must be portable.
 - b. ENSURE that the video-imaging equipment that is used for OH IR inspections includes the following features:
 - (1) Captures and stores images for future analysis
 - (2) Supports interchangeable lenses
 - (3) Offers adjustable, ambient temperature and emittance settings
 - c. ENSURE that approved utility-grade and nonutility-grade IR cameras meet all specifications listed in [Attachment 4, “Minimum Specifications for Approved Infrared Cameras.”](#)

2.3 Records and Documentation

1. WHEN conducting IR inspections under a specific maintenance activity type (MAT), THEN PERFORM the following actions:
 - a. RECORD the inspection in SAP, OR USE [Form TD-2022P-01-F01, “Infrared Inspection Log,”](#) to record the required information. [Form TD-2022P-01-F01](#) is available in hard copy or electronically on PG&E mobile devices.
 - (1) DETERMINE the appropriate maintenance priority based on the temperature values found in [Table 1, “Corrective Maintenance Priorities for Overhead Distribution Facilities,”](#) on Page 7 and [Table 2, “Corrective Maintenance Priorities for Underground Distribution Facilities,”](#) on Page 8.
 - (2) IF there is obvious physical damage,

THEN TAKE corrective action immediately.

Infrared (IR) Inspections of Electric Distribution Facilities

2.3 (continued)

- b. USE [Form TD-2022P-01-F02, "Infrared Data Sheet,"](#) to report identified, abnormal, and compelling conditions. [TD-2022P-01-F02](#) is available either in hard copy or electronically on PG&E mobile devices.
 - (1) DETERMINE the appropriate maintenance priority based on the temperature values found in [Table 1, "Corrective Maintenance Priorities for Overhead Distribution Facilities,"](#) on Page 7, and [Table 2, "Corrective Maintenance Priorities for Underground Distribution Facilities,"](#) on Page 8.
 - (2) IF there is obvious physical damage,

THEN TAKE corrective action immediately.
- c. REPORT defective/damaged components on [Form 62-0113, "Material Problem Report."](#)
 - (1) RETAIN the report for additional analysis as described in [Utility Standard SCM-2106S, "Material Problem Report Standard."](#)
- d. UPLOAD the completed [Form TD-2022P-01-F02](#) to SAP's Electric Corrective (EC) notification.
- e. In SAP, for the notification, ENTER the following:
 - (1) "Infrared Hot Spot found. An infrared Inspection Hot Spot cannot be checked or confirmed visually. You must use an infrared camera. Notification should be standalone. A visual check can only be used to verify equipment has been replaced. Attach a photo of the new equipment in order to proceed with a cancellation. Otherwise, do not combine with other notifications or cancel."
 - (2) Equipment description
 - (3) The IR temperature reading that corresponds to [Table 1](#) or [Table 2](#) that prompted the notification
 - (4) Under **Status**, SELECT **IR**.

2.4 Determining Corrective Maintenance Priorities

1. WHEN determining corrective maintenance priorities,

THEN PERFORM the following steps:
 - a. READ the [Notes to Table 1 and Table 2](#), starting on Page 8.

Infrared (IR) Inspections of Electric Distribution Facilities

2.4 (continued)

- b. REFER to [Table 1](#) and [Table 2](#) to assess and prioritize the relative severity of the conditions found during an inspection.
- c. USE the measured temperatures and temperature differentials provided in the tables to make these determinations, as described in [Step 2.4.1](#) on Page 5.
 - (1) [Table 1, “Corrective Maintenance Priorities for Overhead Distribution Facilities,”](#) on Page 7, and [Table 2, “Corrective Maintenance Priorities for Underground Distribution Facilities,”](#) on Page 8, describe the following methods used when performing IR inspections:
 - **Differential temperature analysis** – Refers to relative temperature values of a hotspot with respect to other parts of the equipment with similar conditions.
 - **Absolute temperature analysis** – Refers to actual temperature values measured from the hotspot.
 - (2) Between the differential and absolute methods, the most reliable is the differential temperature analysis, unlike the absolute temperature analysis, which is minimally influenced by environmental factors, such as ambient temperature, humidity, and emissivity.

Infrared (IR) Inspections of Electric Distribution Facilities

2.4 (continued)

Table 1. Corrective Maintenance Priorities for Overhead Distribution Facilities

Differential Temperature (T) Rise Analysis			
Distribution Facilities	Condition	Temperature Differential (ΔT)	Priority/Due Date
Arrester cut-outs and pot-head termination	Normal	Delta Temperature (ΔT) $\leq 10^{\circ}\text{C}$ $\Delta T \leq 18^{\circ}\text{F}$	No maintenance required
	Minor	$10^{\circ}\text{C} < \Delta T \leq 25^{\circ}\text{C}$ $18^{\circ}\text{F} < \Delta T \leq 45^{\circ}\text{F}$	Write EC tag with Priority B
	Medium	$\Delta T > 25^{\circ}\text{C}$ $\Delta T > 45^{\circ}\text{F}$	Write EC tag with Priority X
Connector and switch	Minor	$25^{\circ}\text{C} < \Delta T \leq 45^{\circ}\text{C}$ $45^{\circ}\text{F} < \Delta T \leq 81^{\circ}\text{F}$	Write EC tag with Priority B
	Medium	$\Delta T > 45^{\circ}\text{C}$ $\Delta T > 81^{\circ}\text{F}$	Write EC tag with Priority X
Absolute Temperature (T) Analysis			
Distribution Facilities	Condition	Temperature Limits	Priority/Due Date
Arrester cut-outs and pot-head termination	Normal	T hot spot $\leq 70^{\circ}\text{C}$ T hot spot $\leq 158^{\circ}\text{F}$	No maintenance required
	Minor	$70^{\circ}\text{C} < \text{T hot spot} \leq 80^{\circ}\text{C}$ $158^{\circ}\text{F} < \text{T hot spot} \leq 176^{\circ}\text{F}$	Write EC tag with Priority B
	Medium	T hot spot $\geq 81^{\circ}\text{C}$ T hot spot $\geq 177^{\circ}\text{F}$	Write EC tag with Priority X
Connector and switch	Normal	T hot spot $\leq 85^{\circ}\text{C}$ T hot spot $\leq 185^{\circ}\text{F}$	No maintenance required
	Minor	$85^{\circ}\text{C} < \text{T hot spot} \leq 105^{\circ}\text{C}$ $185^{\circ}\text{F} < \text{T hot spot} \leq 221^{\circ}\text{F}$	Write EC tag with Priority B
	Medium	T hot spot $> 105^{\circ}\text{C}$ T hot spot $> 221^{\circ}\text{F}$	Write EC tag with Priority X

Infrared (IR) Inspections of Electric Distribution Facilities

2.4 (continued)

Table 2. Corrective Maintenance Priorities for Underground Distribution Facilities

Differential Temperature (T) Rise Analysis			
Distribution Facilities	Condition	Temperature Differential (ΔT)	Priority/Due Date
Elbow and termination	Normal	$\Delta T \leq 6^{\circ}\text{C}$ $\Delta T \leq 11^{\circ}\text{F}$	No maintenance required
	Medium	$\Delta T > 6^{\circ}\text{C}$ $\Delta T > 11^{\circ}\text{F}$	Write EC tag with Priority B
Joint/splice and switch	Minor	$\Delta T \leq 6^{\circ}\text{C}$ $\Delta T \leq 11^{\circ}\text{F}$	No maintenance required
	Medium	$\Delta T > 6^{\circ}\text{C}$ $\Delta T > 11^{\circ}\text{F}$	Write EC tag with Priority B
Absolute Temperature (T) Analysis			
Distribution Facilities	Condition	Temperature Limits	Priority/Due Date
Elbow and termination	Normal	T hot spot $\leq 80^{\circ}\text{C}$ T hot spot $\leq 176^{\circ}\text{F}$	No maintenance required
	Medium	T hot spot $> 80^{\circ}\text{C}$ T hot spot $> 176^{\circ}\text{F}$	Write EC tag with Priority B
Joint/splice and switch	Normal	T hot spot $\leq 85^{\circ}\text{C}$ T hot spot $\leq 185^{\circ}\text{F}$	No maintenance required
	Medium	T hot spot $> 85^{\circ}\text{C}$ T hot spot $> 185^{\circ}\text{F}$	Write EC tag with Priority B

Notes to [Table 1](#) and [Table 2](#) above. SEE [Subsection 2.4](#) above.

1. IF the IR component has failed, has considerable damage, or its condition results in significant exposure to the public, THEN PERFORM the following steps:
 - a. CREATE an EC tag with Priority A.
 - b. INITIATE corrective action immediately.
 - c. REFER to [TD-2305M, Electric Distribution Preventive Maintenance Manual \(EDPM\)](#).
2. CREATE the EC tag.
3. For non-High Fire Threat District (HFTD) and HFTD structures, COMPLETE the required action(s) within the priority, as shown in the "Priority/Due Date" column in [Table 1](#) or [Table 2](#).
4. For live-front terminations on OH and pad-mounted transformers or equipment, USE the OH temperature-differential values to determine priorities, as shown in [Table 1](#).
5. For dead-front terminations on pad-mounted or subsurface transformers, USE the temperature-differential values to determine priorities, as shown in [Table 2](#).
6. [Table 1](#) on Page 7 and [Table 2](#) on Page 8 apply to transformer terminations. When working with transformers, the tank temperature containing the insulating fluid must be evaluated separately. REFER to [Numbered Document 068178, "Distribution Transformer Temperature," Table 1](#), or [Table 2](#), as appropriate, for the type of transformer. REFER to [Utility Procedure TD-2424P-01, "Distribution Transformer Operations," Subsection 2.3, "Troubleshooting,"](#) to identify the use of an IR device during troubleshooting.

Infrared (IR) Inspections of Electric Distribution Facilities

2.4 (continued)

Notes to [Table 1](#) and [Table 2](#) (continued)

7. For underground switches, the ΔT values shown in [Table 2](#) are between **switch components and the bushing-elbow interface**.
8. Temperature conversion factor: $^{\circ}\text{C} = (^{\circ}\text{F} - 32) \times (5/9)$.
9. Temperature differential: $^{\circ}\text{C}_{\text{diff}} = (^{\circ}\text{F}_{\text{diff}}) / 1.8$.

3 Setting Up the IR Camera

NOTE

To obtain accurate measurements, it is critical to establish the IR imaging-system to create parameters for **emissivity and background temperature**.

- 3.1 USE additional imaging-system setup parameters to record heat emissions from a target and its background for initial or future evaluations.
- 3.2 SET the emissivity value to **0.95**. This eliminates the need to set the background temperature. In this case, the target is considered a “black body,” entirely reflective, and non-transmissive.
- 3.3 When dealing with highly emissive targets, the reflected energy is negligible compared to the emitted energy, making temperature measurements suitable and reliable for predictive maintenance applications.
- 3.4 As the emissivity value of the target decreases, the impact of background radiation becomes more pronounced, leading to an increased likelihood of errors in temperature measurements based on background temperature settings.
- 3.5 IF the emissivity value is set below 0.95, AND the background temperature setting is inaccurately adjusted,

THEN there is a higher likelihood that the temperature measurement of the target includes errors compared to when the emissivity value is set at 0.95.

NOTE

1. When the emissivity setting is below 0.95 and the background temperature setting is higher than the actual background temperature, the recorded target temperature measurement is lower than it should be.
2. Conversely, if the background temperature setting is lower than the actual background temperature, the recorded target temperature measurement is higher than it should be. This measurement deviation is compounded as the emissivity setting decreases from 0.95.

1. Setting the emissivity value at 0.95 accomplishes the following:
 - Eliminates the need to determine exact emissivity and background temperature values

Infrared (IR) Inspections of Electric Distribution Facilities

3.5 (continued)

- Simplifies the system operation
- Results in reasonably accurate measurements

NOTE

Obtaining an accurate background temperature in IR measurements on OH systems with an unobstructed sky view is challenging because most targets have dark surfaces with emissivity values close to 0.95.

3.6 IR Inspection Measurement Points

1. SEE the temperature measurement points on various conductor assemblies in [Figure 1, "Infrared Inspection Measurement Points,"](#) on Page 11.

3.7 IR Scanning Technique

1. IF the thermal image's color pallet displays a significant temperature difference between the targeted component and conductor/cable,

THEN PERFORM the following steps:

- a. CENTER the targeted component in the viewer or sight of the IR scanning device AND OBSERVE the measured temperatures.
 - (1) SEE the measurement points in [Figure 1](#) through [Figure 8](#) on Page 11.
- b. SCAN approximately 1 to 2 feet of the conductor/cable entering and/or leaving the targeted image AND OBSERVE the measured temperatures.
 - (1) SEE the measurement points in [Figure 1](#) through [Figure 8](#) on Page 11.

Infrared (IR) Inspections of Electric Distribution Facilities

3.7 (continued)

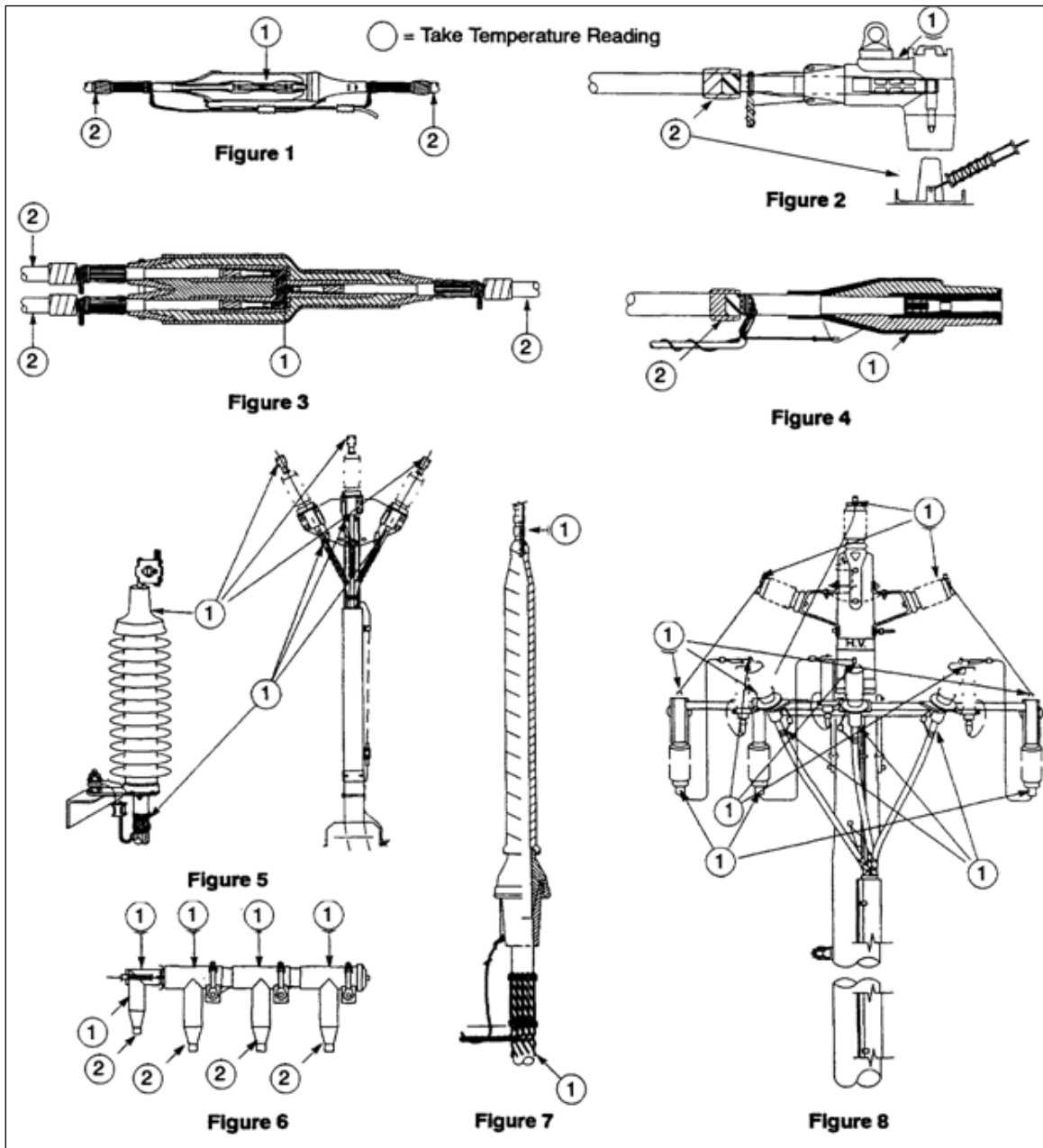

Figure 1. Infrared Inspection Measurement Points

Notes:

1. Numbers 1 and 2 are the measurement points referred to in [Subsection 3.7, "IR Scanning Technique,"](#) on Page 10.
2. Observe excessive temperature readings for figures that designate only measurement points.

Infrared (IR) Inspections of Electric Distribution Facilities

- 3.8 Using an IR Camera to Identify Hot Transformers and UG Switches
1. The IR camera provides thermal images that identify transformer tanks with elevated temperatures caused by high loading. The thermal images also identify switch tanks exhibiting elevated temperatures caused by internal switch issues.
 2. WHEN capturing thermal images of transformer and switch tanks,
PERFORM the following actions:
 - a. WHEN identifying a transformer tank with elevated temperatures,
TAKE the actions described in [Table 1](#) and [Table 2](#) on Pages 7 and 8 and [Numbered Document 068178, "Distribution Transformer Temperature."](#)
 - b. IF the temperature for an oil switch tank exceeds its cable terminations,
THEN CREATE an EC tag with Priority A to initiate an immediate switch replacement.
 - c. For contracted distribution OH inspection (non-aerial drone) work, USE [Attachment 5, "Guideline for Validating Overhead \(OH\) Infrared \(IR\) Inspection Contract Work."](#)

END of Instructions

DEFINITIONS

Abnormal conditions: A condition that impacts or has the potential to adversely impact safety, service reliability, or asset life. Typically, these conditions indicate when the facility may fail to perform its intended function.

Ambient temperature: The prevailing temperature in the immediate vicinity of an object or target; the temperature of the target's environment.

Background temperature: The temperature(s) of the surrounding scene reflected off the target.

Component temperature: The temperature of the surface under evaluation.

Distribution facilities: Any conductors or associated equipment operating at voltages up to 50,000 volts (V), namely 50 kilovolts (kV).

Emissivity: The relative ability of a surface to emit heat from radiation. Emissivity is the ratio of the heat emitted by a surface compared to that emitted by a black body.

Emittance value: The ratio of the intensity of thermal radiation at a given wavelength or spectral waveband from a target to the thermal radiation emitted by a black body with the same temperature as the target.

Infrared (IR) Inspections of Electric Distribution Facilities

DEFINITIONS (continued)

Field of view: The size of the scene surrounding the target, as observed by the infrared (IR) scanner and expressed as the ratio between the size of the scene surrounding the target and the distance between the target and the scanner.

Infrared (IR) notification: A form or electronic record used as a checklist to identify and record a specific, abnormal maintenance condition(s) that impacts safety, service reliability, or asset life.

Infrequent users: Employees including troublemen (T-man), crew foremen, and supervisors who use IR cameras to perform qualitative analysis to help assess the condition of energized electric distribution facilities. Infrequent users are not engaged in everyday IR inspections.

Input form: A form or electronic record used in the field as a checklist to record a specific, abnormal maintenance condition(s) that impacts safety, service reliability, or asset life. The recorded information creates an Electric Preventive Corrective Maintenance (EPCM) notification.

Inspection: In this procedure, “inspection” refers to IR inspections using thermal imaging equipment to observe differential patterns of IR radiation. These patterns provide specific information about a structure system, object, or target. An inspection can also refer to a special type of diagnostic test using IR thermography.

Inspection cycle: Facilities are inspected according to established schedules based on calendar years. Inspections must be conducted and completed within the scheduled calendar year.

Inspection log: A form or electronic record used to document inspections and identify abnormalities that require correction or a follow-up inspection.

Nonutility-grade IR cameras: IR cameras available to infrequent users who are not performing OH or UG inspections. SEE [Attachment 4, "Minimum Specifications for Approved Infrared Cameras,"](#) for more details.

Priority: The urgency to perform repairs identified in a notification.

Reference temperature: The temperature of a like piece of equipment at the same location as that registering the component (“fault”) temperature.

Reflective: The ability of a target to reflect or send back rays. A mirror has a reflective surface with respect to visible light.

Temperature differential (also known as “temperature rise”): The difference in temperature between the component (fault) temperature and the reference temperature.

Thermography: Any photographic, videotape, computer-generated, or graphic record of information derived from an IR inspection.

Infrared (IR) Inspections of Electric Distribution Facilities

DEFINITIONS (continued)

Transmissive: The ability of a medium to allow electromagnetic radiation to pass through it without being reflected or absorbed (i.e., sending or transmitting rays from one point to another). Glass is highly transmissive to visible light.

Utility-grade IR cameras: IR cameras that meet the minimum specification listed in [Attachment 4, "Minimum Specifications for Approved Infrared Cameras."](#)

IMPLEMENTATION RESPONSIBILITIES

The senior director in charge of asset management is responsible for approving, revising, and distributing this procedure.

GOVERNING DOCUMENT

NA

COMPLIANCE REQUIREMENT / REGULATORY COMMITMENT

Information and Records Management:

PG&E Data, Information, and Records are company assets that must be traceable, verifiable, accurate, and complete and can be retrieved upon request. Functional Areas are responsible for complying with the Information & Records Governance Policy, Standards, and the Information and Records Retention Schedule. Refer to [GOV-7101S, "Enterprise Records and Information Management Standard,"](#) for further guidance or contact Information & Records Governance at Information&RecordsGovernance@pge.com.

REFERENCE DOCUMENTS

Developmental References:

[Infraspection Institute Manuals:](#)

- *Infrared Inspection Manual*
- *Infrared Methodology and Technology Manual*
- *Infraspection Instruction Manual, Level II*

[Institute of Electrical and Electronic Engineers \(IEEE\)](#), Abstract: [Robotized inspection of power lines with infrared vision](#)

[Utility Standard TD-2301S, "Patrols and Detailed/Intrusive Inspections of Electric Overhead and Underground Distribution Facilities"](#)

Infrared (IR) Inspections of Electric Distribution Facilities

REFERENCE DOCUMENTS (continued)

Supplemental References:

[Form 62-0113, "Material Problem Report"](#)

[Numbered Document 068178, "Distribution Transformer Temperature"](#)

[TD-2305M, *Electric Distribution Preventative Maintenance Manual \(EDPM\)*](#)

[Utility Standard SCM-2106S, "Material Problem Report Standard"](#)

APPENDICES

NA

ATTACHMENTS

[Attachment 4, "Minimum Specifications for Approved Infrared Cameras"](#)

[Attachment 5, "Guideline for Validating Overhead \(OH\) Infrared \(IR\) Inspection Contract Work"](#)

[Form TD-2022P-01-F01, "Infrared Inspection Log"](#)

[Form TD-2022P-01-F02, "Infrared Data Sheet"](#)

DOCUMENT REVISION

This utility procedure supersedes Utility Procedure TD-2022P-01, "Infrared (IR) Inspections of Electric Distribution Facilities," Rev. 2, dated 12/07/2023.

DOCUMENT APPROVER

██████████ Senior Director, Electric Asset Strategy

DOCUMENT OWNER

██████████, Director, Inspection and Maintenance Strategy

DOCUMENT CONTACT

██████████ Program Manager, Expert, Asset Preventative Maintenance Strategy

██████████ Senior Consulting Electric Standards Engineer, Electric Asset Management
Distribution Standards

Infrared (IR) Inspections of Electric Distribution Facilities

REVISION NOTES

Where?	What Changed?
Entire Document	Edited to clarify text and updated links to referenced documents.
Subsection 2.4	Updated priorities in Table 1 and Table 2
Document Approver, Document Owner, Document Contact	Updated document approver, owner, and titles