



**GAS DESIGN STANDARD  
INSTALLING AND MAINTAINING A  
POLYETHYLENE (PE)  
GAS DISTRIBUTION SYSTEM**

**A-93.1**

**Publication Date:** 12/15/2021 **Effective Date:** 03/01/2022 **Rev.** 11

## Purpose and Scope

This gas design standard (GDS) provides requirements for installing and maintaining the Pacific Gas and Electric Company (PG&E or Company) polyethylene (PE) gas distribution system.

## 1 General Information

### 1.1. Joining PE

- A. For approved joining methods, approved materials, and qualification requirements, see [Appendix A](#).
- B. Standard heat iron fusions are **not** allowed on Aldyl-A material. Use **only** electrofusion or mechanical fittings with Aldyl-A material.
- C. Mechanical fittings are **not** allowed on molded butt fusion fittings such as 3-way tees, 90° elbows, 45° elbows, end caps, reducers, branch saddles, PE valves with molded ends, and tapping tees without pipe pups.
  - (1) **Exception:** ½ in. excess flow valves (EFVs) have molded ends but are made to pipe tolerances and are compatible with mechanical fittings.

### 1.2. Transitions from PE to Steel



#### CAUTION

If the transition joint is exposed to excessive heat when welding, the PE pipe could become damaged.

- A. Take precautions to protect the PE pipe at the point of transition when welding the steel end.
  - (1) Never shorten the steel portion of a transition fitting. Heat from welding can damage the PE pipe if the steel is cut.
  - (2) Protect the transition joint from excessive heat. Do **not** weld, thermite weld, or heat the body of the fitting; **only** butt welding of the steel end is permitted.
- B. During this welding, protect the PE part of the heat-fusion transition fitting from overheating by wrapping the midpoint of the steel part of the fitting with wet cloth to remove heat. Keep the cloth wet during the weld. After completing the weld, leave the wet cloth on the fitting until the steel pipe is cool enough to touch.

Printed copies of this document might be out of date. The Technical Information Library (TIL) has the current version.

# Installing and Maintaining a Polyethylene (PE) Gas Distribution System

A-93.1

Publication Date: 12/15/2021 Effective Date: 03/01/2022 Rev. 11

---

## 1.2 (continued)

- C. Adequately support the exposed PE pipe adjacent to the transition fitting with well-compacted sand or fine soil.

## 1.3. Prefabricated Risers

- A. For installation of pre-fabricated risers, see GDS A-91, "Prefabricated Risers."
- B. Repair any coating damage on risers in accordance with applicable coating/wrap standards.

## 1.4. Thermal Expansion

- A. When installing PE pipe, ensure that all plastic lines are slack before completing final tie-ins to allow for thermal expansion and contraction.

## 1.5. Marking New Service Installations

- A. All new or replaced services must have the curb (or street) marked indicating the location of the new or replaced service. This marking provides identification and location of the gas service pending the update of the service installation by mapping.
- B. IF the local municipalities or agencies have requirements that restrict marking the services,

THEN note the restriction on the gas service record (GSR), per Utility Procedure TD-9500P-14, "Gas Service Records."

## 2 Construction Materials

### 2.1. Pipe

- A. Check the production date on the pipe.
  - (1) Yellow medium density polyethylene (MDPE) pipe more than 3 years old must be scrapped.

### 2.2. Fittings

- A. For approved fittings, see [Appendix A](#).
- B. Fittings and risers stored indoors, or stored outdoors **and** are covered, have an indefinite storage life. Only the PE portion of the riser outside of the riser casing requires a cover. The riser casing itself can be exposed to the elements.

---

Printed copies of this document might be out of date. The Technical Information Library (TIL) has the current version.

### **3 Construction Methods**

#### **3.1. PE Pipe Handling**

- A. Carefully handle PE pipe to eliminate the possibility of damage during loading, unloading, and storage operations.
  - (1) During transport, the pipe must be supported to minimize movement and must be located away from any source of heat, such as equipment or vehicle exhaust.
    - a) Protect pipe against ropes or other securing devices.
    - b) Do **not** use chains to secure the pipe.
    - c) Do **not** place supplies or other equipment on top of the pipe.
- B. String coils of plastic pipe by hand or from a reel.
  - (1) Coils of 4" diameter pipe and larger must be strung from an approved trailer designed for large-diameter, coiled PE pipe as described in GDS M-17.2, "Large Diameter PE Coil Pipe Trailers and Accessories."
    - a) Coils must **not** be rolled over sharp objects OR pulled over rough surfaces.
    - b) String straight lengths by lifting the pipe from the truck to the ground.
    - c) The pipe must be protected from rocks or other abrasive material during this operation and must **not** be dropped from a height.



#### **WARNING**

Considerable force may be required to field bend pipe. If pipe is released during bending the pipe may spring back forcibly causing bodily injury.

- (2) Observe proper safety precautions during field bending of pipe to avoid personnel injury.
- (3) Coiled PE pipe is confined with bands at intervals within the coils. As the pipe is uncoiled, take precautions to avoid kinking the pipe. Do **not** uncoil the pipe faster than the bands can be cut.

3.1 (continued)



**CAUTION**

Damage to the PE pipe can result from welding (weld or thermite weld) too close without protecting the pipe with a heat-resisting baffle or wet rags.

- C. To minimize the possibility of sparks or hot material coming into contact with the plastic pipe, do **not** perform welding on pipe immediately adjacent to plastic pipe.

3.2. Static Charge Build-Up in PE Pipe



**WARNING**

Discharge of static electricity can cause shocks or ignite a gas-air mixture.

- A. Control static charge build up in PE Pipe.
  - (1) Static-electric charges can build up on both the inside and outside surfaces of PE pipe. Localized, static-electric buildup occurs because PE pipe does not readily conduct electricity. See Utility Procedure WP4170-01, "Grounding Polyethylene (PE) Pipe to Control Static Electricity," for static-grounding procedures and requirements.

3.3. Depth of Cover for Main and Service

- A. For depth of cover requirements, see GDS A-04, "Cover and Clearance Requirements for Transmission Lines, Distribution Mains, and Service Lines."

3.4. PE Pipe Pressure Control (Squeeze-Off)

- A. Squeeze off PE pipe to extend or repair it. PE pipe is flexible and can be squeezed shut without damaging the pipe or reducing its pressure rating, provided the proper tools and procedures are used.
- B. For squeeze-off procedures, see Utility Procedure TD-4170P-02, "Squeezing Polyethylene (PE) Pipe."

## Installing and Maintaining a Polyethylene (PE) Gas Distribution System

A-93.1

Publication Date: 12/15/2021 Effective Date: 03/01/2022 Rev. 11

---

### 3.5. Purging Plastic Mains and Services

- A. Remove static-electric charges by grounding the pipe whenever the pipe is purged. Refer to Utility Procedure WP4170-01.
- B. Purge plastic mains and services according to the provisions specified in GDS A-38, "Purging Gas Facilities," as applicable.
- C. If the service has an EFV, follow purging instruction in GDS A-93.3, "Excess Flow Valves."

### 3.6. Gauging Requirements/Continuity of Service

- A. It is Company policy to maintain uninterrupted service to customers during the construction, reconstruction, or maintenance of facilities as described in Distribution & Customer Service (DCS) Standard D-S0454, "Gas Mains, Maintaining Continuity of Service During Construction."

### 3.7. Direct Burial

- A. Warning tape must be installed in direct-burial installations per GDS L-16, "Gas Pipeline Underground Warning Tape."

### 3.8. Insertion of PE Main and Services in Casing

- A. Insert plastic pipe into an existing casing by performing the following steps:
  - (1) Clean the casing pipe.
  - (2) Ream the steel casings to protect the plastic insert from the sharp edges of the casing. Where necessary, the entire length of the casing pipe must be reamed.
  - (3) The leading edge of the plastic pipe or tubing must be sealed during insertion.
  - (4) Push the plastic pipe through the casing.
  - (5) Evaluate the first 5 feet (ft) of the plastic pipe for damage as it leaves the casing pipe.
  - (6) IF there is damage that is caused by the casing pipe,  
  
THEN remove the plastic pipe and repair the pipe as described in [Section 4](#).

---

Printed copies of this document might be out of date. The Technical Information Library (TIL) has the current version.

3.8 (continued)

- B. Support exposed plastic at entry and exit points.
  - (1) Plug the space between the plastic and the casing pipe (see GDS A-90, "Polyethylene Gas Distribution System Design") with casing plugs or cable protectors, duct seal, or other suitable means not detrimental to PE pipe.
  - (2) Support any non-cased plastic pipe with backfill.
- C. Plastic pipe is approved for double insertion into existing mains and services. This application is approved only if the following conditions are met:
  - (1) It is not practical or economical to remove the previously inserted pipe.
  - (2) The installation is made per GDS A-75, "Gas Service and Mains in Plastic Casing," or GDS A-90, as applicable, particularly with respect to protecting and supporting the entry and exit points.
  - (3) The installation is mapped with both the casing size and casing material identified. For example, a ½ in. plastic service inserted into a 1 in. copper pipe that is inserted into a 2 in. steel line is mapped as shown in Figure 1.

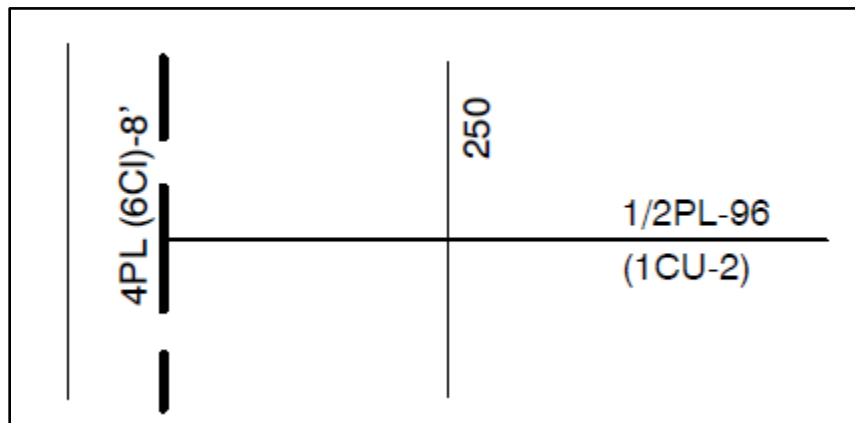

Figure 1. Mapping of a Double Insert

- D. Squeezing of the outer casing is **only** allowed in the event of an emergency. If the outer casing pipe is squeezed, the casing must be grounded. The PE gas-carrier pipe must be replaced after flow control is no longer needed.
  - (1) IF the outer casing is metallic (e.g., steel or copper),  
  
THEN ground the casing using a ground cable that is grounded to wet earth.

## Installing and Maintaining a Polyethylene (PE) Gas Distribution System

A-93.1

Publication Date: 12/15/2021 Effective Date: 03/01/2022 Rev. 11

---

### 3.8 (continued)

- (2) IF the outer casing is PE,  
  
THEN ground the squeezer and casing as if the casing were the carrier pipe in accordance with Utility Procedure WP4170-01.
- (3) IF the casing is polyvinylchloride (PVC) or cast iron,  
  
THEN remove the casing before squeezing the carrier pipe or tubing and ground the carrier pipe per Utility Procedure WP4170-01.
- (4) Take special precautions when accessing the carrier pipe (window cutting) to avoid damaging it.  
  
See Utility Procedure TD-4610P-01, "Accessing Polyethylene Pipe Within Steel Casing."
- (5) IF the pipe is damaged,  
  
THEN the carrier pipe must be repaired by replacing the damage section of the carrier pipe.

### 3.9. Boring or Splitting of PE Main and Service

- A. PE pipe may be pushed or pulled through a borehole as described in the following:
  - (1) Utility Manual TD-4135M, *Horizontal Directional Drilling Manual*
  - (2) GDS M-70.7, "Pneumatic Piercing Tools"
  - (3) Utility Procedure TD-4412P-05, "Excavation Procedures for Damage Prevention"
- B. During pipe pulling, constantly monitor the pulling force on the pipe and use a pulling head containing a weak-link or mechanical breakaway per GDS M-16.2, "Weak-link and Mechanical Breakaway Connectors Used in Polyethylene Pipe Installation."
- C. During horizontal directional drilling (HDD) operations, the equipment gauge pressure must **not** be used to determine pulling forces on the pipe.

---

Printed copies of this document might be out of date. The Technical Information Library (TIL) has the current version.

3.9 (continued)



**CAUTION**

A weak-link or a mechanical break-away is critical to ensuring that PE pipe is installed without exceeding its design load.

- D. Examine the pipe as it leaves the hole to determine if the speed of the pipe is smooth and continuous. Any delay in the pipe pulling may indicate that the pipe has “hung up” and has possible damage.
- E. When installing PE using HDD, minimize variations in the bore to avoid adding drag when pulling back the pipe. Proper back-reaming and mudflow will help reduce the drag on PE when pulling back the pipe.
- F. PE services may be replaced per Utility Procedure TD-4634P-02, “Polyethylene Main and Service Line Splitting Using Winch Method.”
- G. IF pipelines are installed using technologies where a casing is required, including the following:
  - (1) HDD
  - (2) Steel pipe splitting (see GDS A-36.1, “Splitting Steel Pipe”)
  - (3) Cast-iron pipe bursting,

THEN it is acceptable to insert plastic pipe and tubing into a new plastic casing if the installation of the new plastic casing meets the following requirements:

- (1) All the current design requirements per GDS A-75 are satisfied.
- (2) The newly installed products are mapped correctly. For example, the bursting of a 4 in. cast-iron main for the placement of a 4 in. plastic main into a 6 in. plastic casing is mapped as follows: 4 - PL (6PL).

3.10. Riser Insert

- A. Before installing a service head adapter kit, inspect the PE tubing for damage (see Figure 2).
- B. For instructions on service head adapters, see Utility Procedure TD-4170P-52, “Mechanical Fitting Connections for Polyethylene Pipe (Threaded Compression Transitions).”



3.10 (continued)

- C. Support the plastic pipe with well-compacted sand or fine soil.
- D. For locating wire requirements, see GDS A-90.2, "Locating Wire Installation for Plastic Mains and Services."

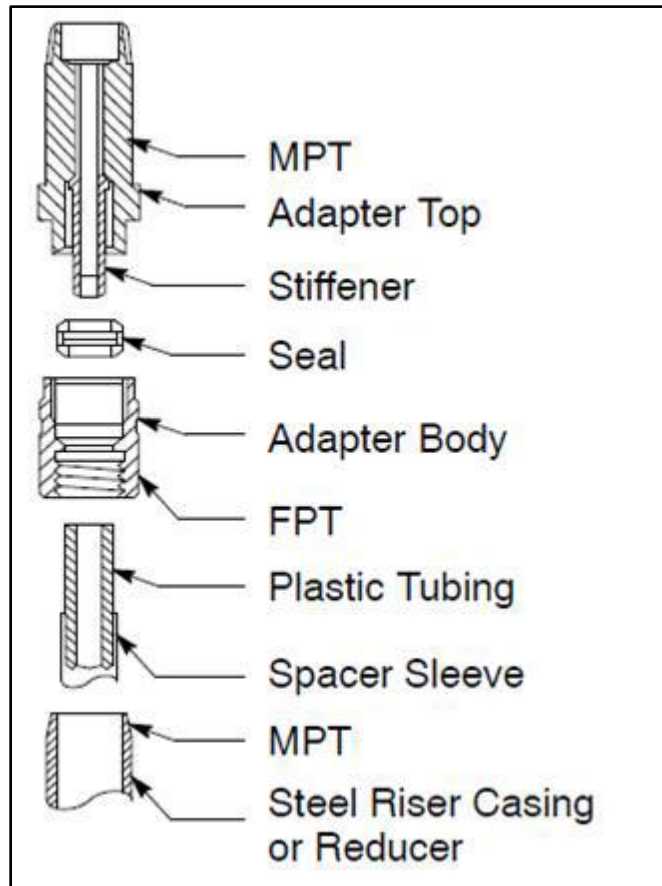

**Figure 2. Service Head Adapter**

3.11. Unsupported Pipe Spacing

- A. Determine the maximum unsupported length of pipe in an excavation using Table 1.

**Table 1. Maximum Unsupported Pipe Length**

Nominal Size (inches)	Maximum (feet)
2	4.9
4	6.5
6	7.9
8	9.1

# Installing and Maintaining a Polyethylene (PE) Gas Distribution System

A-93.1

Publication Date: 12/15/2021 Effective Date: 03/01/2022 Rev. 11

---

## 3.12. Damage Inspection and Assessment

- A. Carefully inspect PE pipe for debris, kinks, gouges, scratches, punctures, and other imperfections after each of the handling operations and before and during installation.
- B. IF PE pipe has defects of damages exceeding 10% of the wall thickness of the pipe,  
  
THEN the pipe must be rejected, and existing pipe replaced. Pipe wall thicknesses are listed in GDS A-93, "Polyethylene Pipe Specifications and Design Considerations."
  - (1) See Job Aid TD-A-93.1-JA01, "DGP-4 Pit Gauge for Polyethylene (PE) Pipe Wall Loss," on guidelines for measuring PE pipe loss.

## 4 PE Pipe Repairs

### 4.1. General Requirements

- A. Make permanent repairs by replacing the damaged segment of plastic pipe.
- B. Test segments of plastic pipe that are installed to replace damaged sections of mains and services per GDS A-34, "Piping Design and Test Requirements."
  - (1) Soap test mechanical fittings and couplings during leak testing.
  - (2) Soap test the repair and squeeze areas after the repair is complete.
- C. Make permanent repairs to Nipak and Continental tapping tees with damaged caps by replacing the cap with the approved replacement caps listed in GDS B-90.2, "Polyethylene (PE) System Accessories."
- D. A Performance Pipe 980 Quad Ring may be used to repair the Phillips Driscopipe old style orange resin tee (see Utility Procedure TD-4170P-57, Attachment 1, "Tapping Tee Identification and Component Replacement Kits"). The tee can be identified by the presence of a Quad Ring located at the top of the tapping tower.
- E. Do not use mechanical leak repair clamps as a repair method for plastic pipe.

### 4.2. Repair and Test Requirements for PE Pipe Damaged by Dig-in or Other Causes

- A. Visually inspect the plastic pipe upstream and downstream from the area of contact.
- B. Replace only enough pipe to make a permanent repair.

---

Printed copies of this document might be out of date. The Technical Information Library (TIL) has the current version.

# Installing and Maintaining a Polyethylene (PE) Gas Distribution System

A-93.1

Publication Date: 12/15/2021 Effective Date: 03/01/2022 Rev. 11

---

## 4.2 (continued)

- C. Pressure leak test plastic pipe to be used for repair on site.
- D. Leak test the replaced section per GDS A-34.
- E. IF the casing is damaged (e.g., broken, bent, or crushed),  
THEN replace the plastic carrier pipe 2 ft upstream and downstream of the dig-in location.

## 4.3. Repairing a Service

- A. To determine if a service needs to be repaired or replaced, see Utility Standard TD-4801S, "Service Replacement Criteria."
- B. Pressure test service lines from the point of disconnection to the riser.
- C. IF, in a dig-in situation, it appears that the pipe or casing was pulled or moved between the point of impact and the main,  
THEN leak test per GDS A-34.

## 4.4. Plastic Service-Inserted Risers and Prefabricated Risers

- A. IF a PE service-inserted riser or prefabricated riser has been subjected to unusually high temperatures (such as being exposed to a house fire or meter fire),  
THEN immediately replace either the plastic insert or the entire riser.



### CAUTION

Pressure testing the service is **not** sufficient when a riser has been exposed to high temperatures. The plastic piping inside the riser could be damaged even though the pipe may hold during a leak test. When the service is used on a long-term basis, it could eventually rupture.

- B. IF a PE service-inserted riser or prefabricated riser casing has been damaged or corroded to where the riser is unable to support itself,  
THEN immediately replace either the plastic insert or the entire riser.
- C. Electric grounding or bonding wires must not be attached to any part of a PE service-inserted riser, prefabricated riser, or locating wire.

---

Printed copies of this document might be out of date. The Technical Information Library (TIL) has the current version.

## Installing and Maintaining a Polyethylene (PE) Gas Distribution System

A-93.1

Publication Date: 12/15/2021 Effective Date: 03/01/2022 Rev. 11

---

### 4.5. Dura-Line Pipe Connections

- A. Do not pressurize Dura-Line PolyPipe ½ in. copper tubing size (CTS), 1 in. CTS, or 1¼ in. iron pipe size (IPS) piping that was previously installed, but not yet tied-in.
- B. Whenever making a new connection to Dura-Line PolyPipe ½ in. CTS, 1 in. CTS, or 1¼ in. IPS piping, use only electrofusion or socket fusion. Mechanical fittings are not approved.
  - (1) If the Dura-Line PolyPipe ½ in. CTS, 1 in. CTS, or 1¼ in. IPS piping was capped with a Continental Constab Cap-n-Go coupling with a verified 100 pounds per square inch gauge (psig) air test, then the existing Cap-n-Go coupling is approved for connection.

### 4.6. Material Problem Report (MPR)

- A. A MPR is required for the following PE connection leaks:
  - (1) All fusion leaks, regardless of grade.
  - (2) All leaks found on Dura-Line PolyPipe ½ in. CTS, 1 in. CTS, or 1¼ in. IPS piping, regardless of connection type (fusion or mechanical).
  - (3) All Grade 1 leaks, regardless of connection type (fusion or mechanical).
  - (4) All connections (fusion or mechanical) that fail leak test.
- B. Submit a MPR by completing the following:
  - (1) Take a photo of the overall fusion and of the defect of the fusion prior to removal.
  - (2) Remove the leaking connection by cutting a minimum of 12 in. from both sides of the joint.
  - (3) Generate a MPR per Utility Procedure SCM-2106P-01, "Material Problem Report Procedure" and attach photos taken in the field.
  - (4) Tag and carefully package the fitting or connection along with the MPR number and leak notification number.
  - (5) Ship the package to the following address:

ATTN: MPR Shed  
3400 Crow Canyon Road  
San Ramon, CA 94583

---

Printed copies of this document might be out of date. The Technical Information Library (TIL) has the current version.

# Installing and Maintaining a Polyethylene (PE) Gas Distribution System

A-93.1

Publication Date: 12/15/2021 Effective Date: 03/01/2022 Rev. 11

---

## Target Audience

Gas distribution engineers, gas planners, estimators, new business inspectors, maintenance and construction (M&C) crews, materials inspectors, and personnel involved in PE pipe connection training and qualification.

## Definitions

NA

## Compliance Requirement / Regulatory Commitment

Code of Federal Regulations (CFR) Title 49, Transportation, Part 192—Transportation of Natural and other Gas by Pipeline: Minimum Federal Safety Standards, Section 192.321, “Installation of plastic pipe.”

Code of Federal Regulations (CFR) Title 49, Transportation, Part 192—Transportation of Natural and other Gas by Pipeline: Minimum Federal Safety Standards, Section 192.617, “Investigation of failures.”

Code of Federal Regulations (CFR) Title 49, Transportation, Part 192—Transportation of Natural and other Gas by Pipeline: Minimum Federal Safety Standards, Section 192.720, “Distribution systems: Leak repair.”

### *Records and Information Management:*

Information or records generated by this procedure must be managed in accordance with the Enterprise Records and Information (ERIM) Policy, Standards and Enterprise Records Retention Schedule (ERRS). Refer to GOV-7101S, “Enterprise Records and Information Management Standard,” and related standards. Management of records includes, but is not limited to:

- Integrity
- Storage
- Retention and Disposition
- Classification and Protection

# Installing and Maintaining a Polyethylene (PE) Gas Distribution System

A-93.1

Publication Date: 12/15/2021 Effective Date: 03/01/2022 Rev. 11

---

## References

Distribution & Customer Service (DCS) Standard D-S0454, "Gas Mains, Maintaining Continuity of Service During Construction"

Engineering Material Specification EMS-4123, "Backfill Sand"

Gas Design Standard A-04, "Cover and Clearance Requirements for Transmission Lines, Distribution Mains, and Service Lines"

Gas Design Standard A-34, "Piping Design and Test Requirements"

Gas Design Standard A-36.1, "Splitting Steel Pipe"

Gas Design Standard A-38, "Purging Gas Facilities"

Gas Design Standard A-75, "Gas Service and Mains in Plastic Casing"

Gas Design Standard A-90, "Polyethylene Gas Distribution System Design"

Gas Design Standard A-90.2, "Locating Wire Installation for Plastic Mains and Services"

Gas Design Standard A-91, "Prefabricated Risers"

Gas Design Standard A-93, "Polyethylene Pipe Specifications and Design Considerations"

Gas Design Standard A-93.3, "Excess Flow Valves"

Gas Design Standard B-54, "Compression Couplings"

Gas Design Standard B-90, "Plastic System Socket and Butt Fusion Fittings"

Gas Design Standard B-90.1, "Plastic System Saddle Fittings")

Gas Design Standard B-90.2, "Polyethylene (PE) System Accessories"

Gas Design Standard B-90.3, "Electrofusion Fittings and Tapping Tees")

Gas Design Standard B-91, "Transition Fittings for Polyethylene Pipe"

Gas Design Standard B-91.1, "Polyethylene (PE) System Mechanical Fittings")

Gas Design Standard D-34, "Qualifications for Joining Polyethylene Pipe"

Gas Design Standard F-90, "Polyethylene (PE) Valves"

Gas Design Standard L-16, "Gas Pipeline Underground Warning Tape"

---

Printed copies of this document might be out of date. The Technical Information Library (TIL) has the current version.

# Installing and Maintaining a Polyethylene (PE) Gas Distribution System

A-93.1

Publication Date: 12/15/2021 Effective Date: 03/01/2022 Rev. 11

---

## References (continued)

Gas Design Standard M-16.2, "Weak-link and Mechanical Breakaway Connectors Used in Polyethylene Pipe Installation"

Gas Design Standard M-17.2, "Large Diameter PE Coil Pipe Trailers and Accessories"

Gas Design Standard M-70.7, "Pneumatic Piercing Tools"

Utility Manual TD-4135M, *Horizontal Directional Drilling Manual*

Utility Procedure SCM-2106P-01, "Material Problem Report Procedure"

Utility Procedure TD-4170P-31, "Heat Iron Socket Fusion for Polyethylene Pipe"

Utility Procedure TD-4170P-33, "Heat Iron Saddle Fusion for Polyethylene Pipe (Mechanical Assist Tool)"

Utility Procedure TD-4170P-34, "Heat Iron Butt Fusion for Polyethylene Pipe (Mechanical)"

Utility Procedure TD-4170P-35, "Heat Iron Butt Fusion for Polyethylene Pipe (Hydraulic)"

Utility Procedure TD-4170P-40, "Electrofusion for Polyethylene Pipe (Coupling)"

Utility Procedure TD-4170P-41, "Electrofusion for Polyethylene Pipe (Saddle)"

Utility Procedure TD-4170P-42, "Electrofusion for Polyethylene Pipe (Elbow)" Utility Procedure TD-4170P-50, "Mechanical Fitting Connections for Polyethylene Pipe (Stub Outlet)"

Utility Procedure TD-4170P-51, "Mechanical Fitting Connections for Polyethylene Pipe (Lyal Lycofit)"

Utility Procedure TD-4170P-52, "Mechanical Fitting Connections for Polyethylene Pipe (Threaded Compression Transitions)."

Utility Procedure TD-4170P-53, "Mechanical Fitting Connections for Polyethylene Pipe (Bolt-On Saddle)"

Utility Procedure TD-4170P-57, "Polyethylene Tapping Tee Repair Kits."

Utility Procedure TD-4412P-05, "Excavation Procedures for Damage Prevention"

Utility Procedure TD-4610P-01, "Accessing Polyethylene Pipe Within Steel Casing"

Utility Procedure TD-4634P-02, "Polyethylene Main and Service Line Splitting Using Winch Method"

---

Printed copies of this document might be out of date. The Technical Information Library (TIL) has the current version.

# Installing and Maintaining a Polyethylene (PE) Gas Distribution System

A-93.1

Publication Date: 12/15/2021 Effective Date: 03/01/2022 Rev. 11

---

## References (continued)

Utility Procedure TD-9500P-14, "Gas Service Record"

Utility Procedure WP4170-01, "Grounding Polyethylene (PE) Pipe to Control Static Electricity"

Utility Procedure TD-4170P-02, "Squeezing Polyethylene (PE) Pipe"

Utility Standard TD-4801S, "Service Replacement Criteria"

## Appendices

[Appendix A, "Polyethylene Joining Method and Approved Material References"](#)

## Attachments

Job Aid A-93.1-JA01, "DGP-4 Pit Gauge for Polyethylene (PE) Pipe Wall Loss"

## Revision Notes

Revision 11 has the following changes:

1. Removed references to sun shields in Section 1.
2. Updated squeeze off reference to current procedure Utility Procedure TD-4170P-02.
3. Removed backfill requirements in Section 3. Content has been incorporated in GDS A-03.
4. Updated splitting procedure reference to Utility Procedure TD-4634P-02 in Section 3.
5. Removed the requirement to rinse leak soap with clear water after performing soap test in Section 4.
6. Removed the following content that was moved to new GDS A-00, "Polyethylene Pipeline Components and Fittings Replacement Criteria":
  - Step 4.3 - Aldyl-A tee cap
  - Step 4.4 - Plexco Tee Caps
  - Step 4.8 - Kerotest Compression end valves
7. Added language to clarify the timeline for removal of plastic inserted and pre-fab risers exposed to excessive heat in Section 4.
8. Added requirements for connections to Dura-Line ½ in. CTS, 1 in. CTS, or 1¼ in. IPS piping in Section 4.

---

Printed copies of this document might be out of date. The Technical Information Library (TIL) has the current version.



# Installing and Maintaining a Polyethylene (PE) Gas Distribution System

A-93.1

Publication Date: 12/15/2021 Effective Date: 03/01/2022 Rev. 11

---

## Revision Notes (continued)

9. Moved MPR requirement language to Section 4 and updated for clarity.
10. Removed qualification suspension and reinstatement information, because it is covered in GDS D-34 and Utility Procedure TD-4008P-03.
11. Updated reference documents to add:
  - Utility Procedure TD-4170P-02, "Squeezing Polyethylene (PE) Pipe"
  - Utility Procedure TD-4170P-42, "Electrofusion for Polyethylene Pipe (Elbow)"
  - Utility Procedure TD-4170P-51, "Mechanical Fitting Connections for Polyethylene Pipe (Lyal Lycofit)"
  - Utility Procedure TD-4634P-02, "Polyethylene Main and Service Line Splitting Using Winch Method"
12. Updated Appendix A to add:
  - Utility Procedure TD-4170P-42, "Electrofusion for Polyethylene Pipe (Elbow)"
  - Utility Procedure TD-4170P-51, "Mechanical Fitting Connections for Polyethylene Pipe (Lyal Lycofit)"

**Asset Type:** Distribution Mains, Distribution Services

**Function:** Construction, Maintenance

**Document Contact:** [Gas Design Standard Responsibility List](#)

**Appendix A, Polyethylene Joining Method and Approved Material References**

**Page 1 of 2**

**Joining Polyethylene (PE)**

1. Only personnel qualified under GDS D-34, "Qualifications for Joining Polyethylene Pipe," can make connections to plastic gas distribution facilities.
2. Connections within the PE system must be made with the following:
  - Heat socket fusion and butt fusion (GDS B-90, "Plastic System Socket and Butt Fusion Fittings")
  - Heat saddle fusion (GDS B-90.1, "Plastic System Saddle Fittings")
  - Electrofusion (GDS B-90.3, "Electrofusion Fittings and Tapping Tees")
  - Mechanical connection (GDS B-91, "Transition Fittings for Polyethylene Pipe," and GDS B-91.1, "Polyethylene (PE) System Mechanical Fittings")
3. Qualified personnel must join PE pipe and fittings per approved heat-iron or electrofusion joining procedures:
  - Utility Procedure TD-4170P-31, "Heat Iron Socket Fusion for Polyethylene Pipe"
  - Utility Procedure TD-4170P-33, "Heat Iron Saddle Fusion for Polyethylene Pipe (Mechanical Assist Tool)"
  - Utility Procedure TD-4170P-34, "Heat Iron Butt Fusion for Polyethylene Pipe (Mechanical)"
  - Utility Procedure TD-4170P-35, "Heat Iron Butt Fusion for Polyethylene Pipe (Hydraulic)"
  - Utility Procedure TD-4170P-40, "Electrofusion for Polyethylene Pipe (Coupling)"
  - Utility Procedure TD-4170P-41, "Electrofusion for Polyethylene Pipe (Saddle)"
  - Utility Procedure TD-4170P-42, "Electrofusion for Polyethylene Pipe (Elbow)"

**OR** following approved mechanical fitting installation procedures:

  - Utility Procedure TD-4170P-50, "Mechanical Fitting Connections for Polyethylene Pipe (Stab Outlet)"

**Appendix A, Polyethylene Joining Method and Approved Material References  
Page 2 of 2**

3 (continued)

- Utility Procedure TD-4170P-51, “Mechanical Fitting Connections for Polyethylene Pipe (Lyal Lycofit)”
- Utility Procedure TD-4170P-52, “Mechanical Fitting Connections for Polyethylene Pipe (Threaded Compression Transitions)”
- Utility Procedure TD-4170P-53, “Mechanical Fitting Connections for Polyethylene Pipe (Bolt-On Saddle)”

**Construction Materials**

1. Heat Fusion Fittings are listed in GDS B-90 and GDS B-90.1.
2. Electrofusion Fittings are listed in GDS B-90.3.
3. PE-to-PE mechanical connections are listed in the following standards:
  - GDS B-90.1
  - GDS B-91
  - GDS B-91.1
4. Transition fittings are listed in the following standards:
  - GDS B-54, “Compression Couplings”
  - GDS B-91
  - GDS B-91.1
5. Excess flow valves are listed in GDS A-93.3.
6. Plastic valves are listed in GDS F-90, “Polyethylene (PE) Valves.”
7. Prefabricated risers are listed in GDS A-91.