

Appendix S: PROTECTION ALTERNATIVES FOR VARIOUS GENERATOR CONFIGURATIONS

S1. Standard Interconnection Methods with Typical Circuit Configuration for Single or Multiple Units

Note: The protection requirements and station configurations will depend on the voltage class and the size and number of generation units. All new busses must be BAAH however building in a BAAH configuration and operating as a ring is acceptable.

Where the existing PG&E bus configuration is a BAAH configuration, typically the generator will interconnect as shown in Figure S1. Line sequencing may change to balance load and generation.

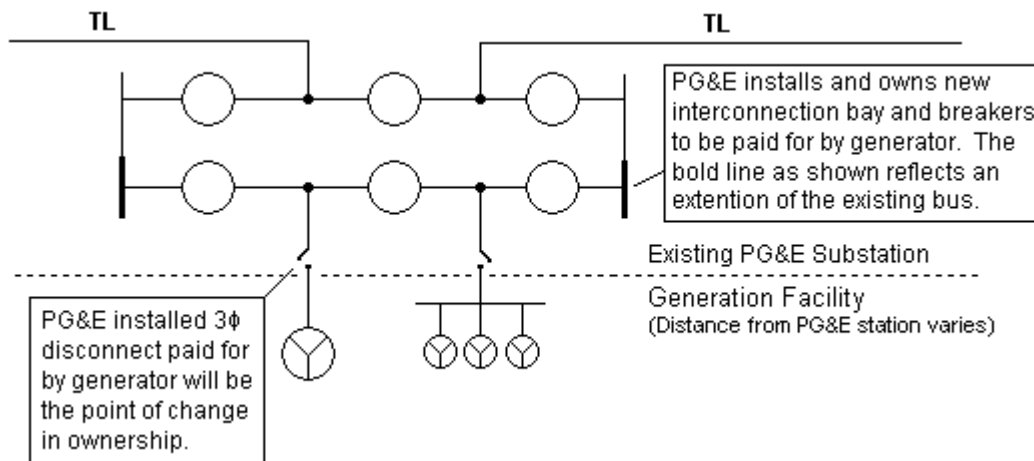
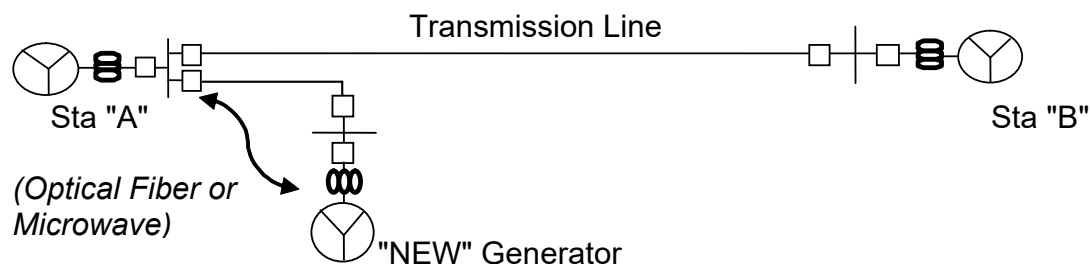

Figure S1. Typical Interconnection into an Existing PG&E Breaker and a Half Substation

S1.1. Bus Fault Clearing



1. Can clear bus faults--Sta "A" and the "NEW" generator can be protected by two differentially connected relays for pilot protection, using digital communication equipment and medium1.

2. Cannot clear for bus faults--When the "NEW" generator cannot clear BUS Faults substation Sta "A" a DTT signal must be sent to clear the faults at the "NEW" generator site. The DTT feature may be incorporated as a function within the respective current differential relaying schemes, provided the relay and medium selected support DTT.

S1.2. Interconnection Methods with Special Circuit Configurations for Single Unit

S2.1. Alternative--Generator "Tapping" To Existing Transmission Line between Two Terminals, considered only at voltages below 100kV

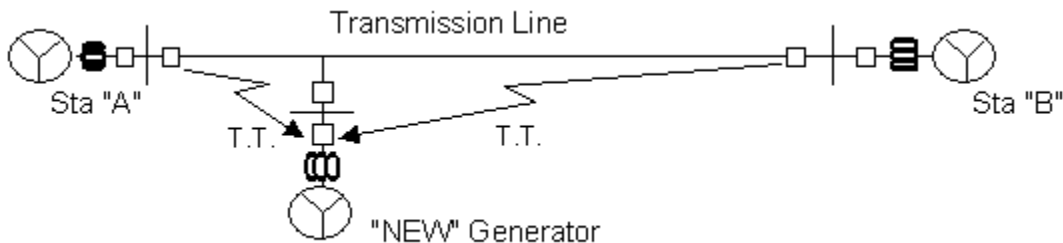

1. Can clear faults--If the "NEW" generator can clear faults on its interconnecting transmission line, additional communications-based protection to trip the "NEW" generator may not need to install at Sta "A" or Sta "B".
2. Cannot clear faults--If the "NEW" generator cannot clear faults on its interconnecting transmission line, Sta "A", Sta "B", or both Sta "A" and Sta "B" will be required to be equipped with Transfer Trip (TT) equipment to send Direct Transfer Trip (DTT) signal(s) to clear for faults on the interconnecting transmission line.

Notes:

- a. Application of DTT is independent of line protection¹.
- b. The DTT transfer trip receiver signal must be wired to trip the generator breaker.
3. When the line is protected by current differential relays or phase comparison type relay systems, the DTT may be incorporated as part of the line protection. (see [S2.6](#))

¹ Refer to Appendix F for communication-assisted protection and associated requirements.

S2.3. Generator “Tapping” closely outside the Substation Between Two Existing Terminals for below 100 kV only and by approved exception.

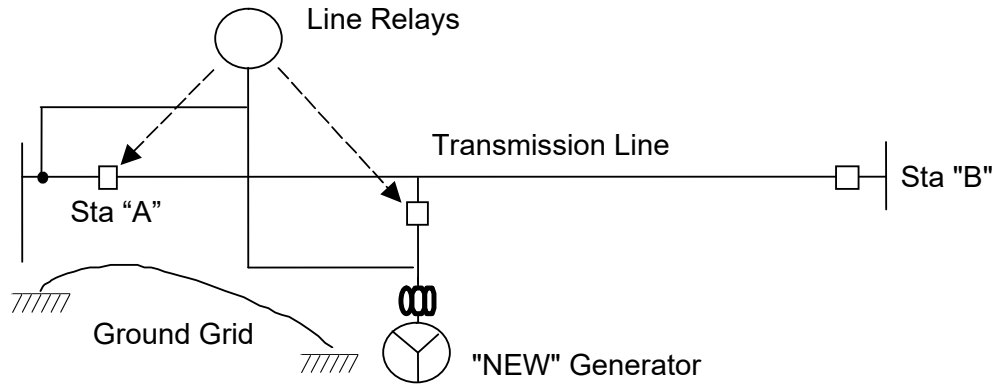

The following applies:

- Connect ground grids between Sta “A” and “NEW” generator together.
- Combine Current Transformer (CT) inputs from Sta “A” breaker and the “NEW” generator breaker to line relays at Sta “A”.
- Line relays trip both Sta “A” breaker and either the “NEW” generator line breaker terminal, or in the absence of the line breaker, will be wired to trip the generator breaker via a auxiliary relays. The auxiliary relays must be suitable for tripping and lockout applications.
- PG&E reclose block is supervised by line voltage or generator’s breaker status.
- PG&E breaker failure relay trips the generator breaker directly via an auxiliary relay.
- This configuration may require DTT from Sta “B”.
- See [S2.5](#) and [S2.6](#)

S2.4. Generator “Connected Close” Outside the Substation with a Dedicated Line

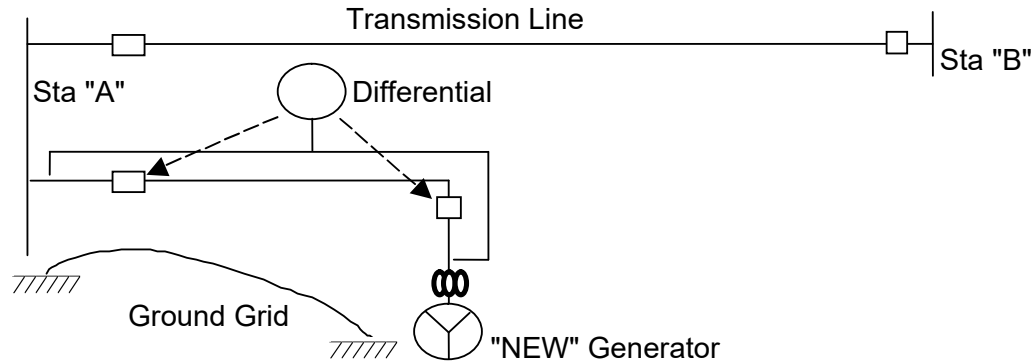

The following applies:

- Connect ground grids together between Sta “A” and the “NEW” generator station (not required if fiber optic network is used)
- Install new line differential relays at Sta “A”.
- Connect CT inputs from Sta “A” breaker and “NEW” generator’s breaker to line differential relay.
- Line differential relay trip Sta “A” breaker and the “NEW” generator breaker via auxiliary relays.
- Direct trip “NEW” generator breaker via an auxiliary relay for Sta “A” breaker failure.
- See [S2.5](#) and [S2.6](#)

S2.5. Requirements for S2.3 and S2.4 Alternatives

- A Ground Grid study² is required for both Stations “A” and “B” and the “NEW” generator to determine conductor size and routing.
- Each generating site needs to conform to the [IEEE Std 80-2000](#) for grounding requirements.
- Transient Studies are required to determine the amount of exposure to PG&E and the respective “NEW” generating facility equipment prior to PG&E performing a detailed feasibility evaluation and specifying the equipment specification. Exposure in this instance refers to the susceptibility of PG&E’s system to excessive transient voltage dip, frequency deviation, or voltage deviation.
- Interposing relays are required for tripping and status circuits between Sta “A” and the “NEW” generating facility and to isolate the DC control batteries.

² PG&E may be contacted for a list of consultants who can provide this type of service.

- The Generation Entity must be aware that common ground grid could result in additional exposure to transients caused by switching and faults at Sta “A”. Operating procedures and protection needs to be in place to address bypassing of breaker at Sta “A” for maintenance or other clearances. Otherwise the “NEW” generating facility will need to be cleared.

S2.6. Additional Items for Consideration

- Design and operating standards are not available for alternatives [S2.3](#) and [S2.4](#).
- For alternatives S2.2 and [S2.3](#), [NERC](#) redundancy requirements should be followed as appropriate for the voltage level.
- Alternatives [S2.1](#) and [S2.3](#) are not recommended if existing line protection uses a power line carrier. Two concerns are:
 - Signal will be degraded unless wave trap is installed at the new generation facility.
 - Risk of over-tripping for faults in “NEW” generator facility
- Economic analysis is recommended to compare alternatives [S2.1](#) and [S2.3](#), or S2.2 and [S2.4](#).
- When simulating “End-of-Line” faults, generator unit steady state synchronous impedance shall be considered.