

**BEFORE THE UNITED STATES
FEDERAL ENERGY REGULATORY COMMISSION**

APPLICATION FOR PRELIMINARY PERMIT

**PG&E Humboldt WaveConnect Project
Project No. _____**

Pacific Gas & Electric Company

February 26, 2007

PRELIMINARY PERMIT APPLICATION FOR THE PG&E HUMBOLDT WAVECONNECT PROJECT

Initial Statement

1. Statement of Application.

Pacific Gas & Electric Company (“PG&E”) hereby applies to the Federal Energy Regulatory Commission (“FERC”) for a preliminary permit for the proposed PG&E Humboldt WaveConnect Project. This project, as described in the attached exhibits, will initially serve to demonstrate the feasibility of generating electric power from waves off the coast of Humboldt County, California. During the preliminary permit period, PG&E will obtain the data and perform the acts required to determine the feasibility of a large scale wave energy project, up to 40 MW in installed capacity, and to support an application for a license for such a project. This preliminary permit application is made in order that the applicant may secure and maintain priority of application for a license for the project under Part I of the Federal Power Act.

2. Project Location.

The project will be located in the Pacific Ocean off the coast of the city of Eureka and the Samoa Peninsula in Humboldt County, California, within a project site that is situated in the open ocean approximately 2 to 10 miles from shore. The wave energy conversion (“WEC”) devices that are being considered for the project float on the surface of the ocean and operate optimally in locations where water depths range from 60 to 600 feet. This application covers a project site that has approximate dimensions of 8 miles wide (predominantly in the east-west direction) by 17 miles long (predominantly in the north-south direction) resulting in a project area of 136 square miles. A project area of this size is required to allow flexibility for performing the necessary assessments and properly siting the project components, recognizing that the final project will have a much smaller footprint (see Exhibit 3 – Project Map). PG&E anticipates that many smaller regions within this larger project site will not be suitable for development and will be excluded from the resultant license application. The project area has the following coordinates:

ID	Latitude	Longitude
1	40° 40.981'N	124° 19.736'W
2	40° 54.768'N	124° 10.894'W
3	40° 58.056'N	124° 19.622'W
4	40° 44.454'N	124° 28.693'W

A subsea transmission cable will carry power from the project area to shore (see Exhibit 3 – Project Map for proposed location) for connection to the grid in Eureka.

The project area is located in an area with excellent wave resources. The National Oceanic and Atmospheric Administration National Data Buoy Center (“NDBC”) operates a wave measurement buoy (Station ID: 46022) located about 15 miles southwest of Eureka in a water depth of 1,670 feet. The station has collected data from 1982 to the present, providing a comprehensive data set that can be used for initial technical evaluations. This measurement station is a good proxy for the available wave energy resource at the proposed project site. Data collected at this buoy show significant wave action in the general project area with monthly average wave heights ranging from 6 to 10 feet. Analysis of the 24-year data set show an average wave power density of 37.9 kW/m. Monthly average ocean water temperatures in this area range from 52 to 58 degrees Fahrenheit and the monthly average wind speeds range from 8 to 13 knots.

3. Name, Business Address, and Telephone Number of Applicant.

Pacific Gas and Electric Company
 Energy Supply
 245 Market Street, MC N13-1360
 San Francisco, CA 94105-1814
 Telephone: (415) 973-3806

Pacific Gas and Electric Company
 Law Department
 77 Beale Street, MC-B30A-2479
 San Francisco, CA 94105-1814
 Telephone: (415) 973-7145

//

//

The following persons are authorized to act as agents for the applicant in the application:

Mr. Roy Kuga, Vice President - Energy Supply
Pacific Gas and Electric Company
P. O. Box 770000, MC N13-1360
San Francisco, CA 94177
Telephone: (415) 973-3806
Facsimile: (415) 973-1859
E-Mail: RMK4@pge.com

Annette Faraglia, Esq.
Pacific Gas and Electric Company
Law Department
P. O. Box 7442, MC B30A-2479
San Francisco, CA 94120-7442
Telephone: (415) 973-7145
Facsimile: (415) 973-5520
E-Mail: ARF3@pge.com

4. Preference under Section 7(a) of the Federal Power Act.

PG&E is a domestic corporation of the U.S. and is not claiming preference under Section 7(a) of the Federal Power Act.

5. Term of Permit.

The proposed term of the requested permit is 36 months.

6. Existing Dams or Other Project Facilities.

There is no existing dam or other project facility as part of the proposed project.

//
//
//
//
//
//
//
//
//
//

EXHIBIT 1

PROJECT DESCRIPTION

1. Project Configuration.

There will be no proposed structures such as dams, spillways, penstocks, powerhouses, or tailraces associated with the proposed PG&E Humboldt WaveConnect Project.

The PG&E Humboldt WaveConnect Project will use WEC devices to transform the energy of ocean waves into clean, renewable electricity. A number of different device concepts are being pursued by independent device manufacturers, and there is no industry consensus at this time on the optimal energy conversion technology. One of the initial steps of the PG&E Humboldt WaveConnect Project will be to provide an infrastructure to deploy and evaluate, relative to the specific requirements of the proposed Humboldt site, a number of different WEC devices in order to identify the best technology solutions, consider environmental effects, and estimate development costs associated with this site. As technical, environmental, and economic considerations are understood and addressed, the project is planned to be built-out to an installed capacity of 40 MW with the technology(ies) best suited for this location. The initial WEC devices to be used will be selected from device manufacturers who have sufficiently mature technologies available for deployment.

Multiple individual WEC devices will be arranged in an array ('wave farm') which will be located 2 to 10 miles from the shoreline as shown in the figure in Exhibit 3. The length of the array (distance parallel to shoreline) will be determined by individual device performance and inter-device spacing requirements. Most of the WEC devices currently being considered by PG&E float on the surface of the ocean but perform optimally at a specific water depth; accordingly, depths ranging from 60 to 600 feet will be considered for placement of various devices.

The WEC devices are independent modules, each with rated capacities ranging from 150 kW to 4 MW. The devices in the array will be connected electrically in clusters to a subsea transmission cable, which will transport the generated power to shore. The WEC devices will be moored to the ocean floor and can be easily installed and uninstalled as necessary for operation

and maintenance. The final physical configuration of the array will be determined following completion of the feasibility studies conducted during the preliminary permit period.

The proposed project will consist of three main components as illustrated in Figure 1: 1) the offshore infrastructure; 2) a subsea transmission cable comprising power cables and fiber-optic communication cables; and 3) the onshore infrastructure. The offshore system components will consist of multiple WEC devices and their associated infrastructure (anchors, mooring lines, power cables to the junction box, etc.) and the junction box. The junction box will include appropriate power conditioning transformers and circuit breakers that receive power from each WEC. Various aids to navigation will be positioned around the deployment area in accordance with U.S. Coast Guard requirements.

FIGURE 1
PG&E HUMBOLDT WAVECONNECT PROJECT DIAGRAM

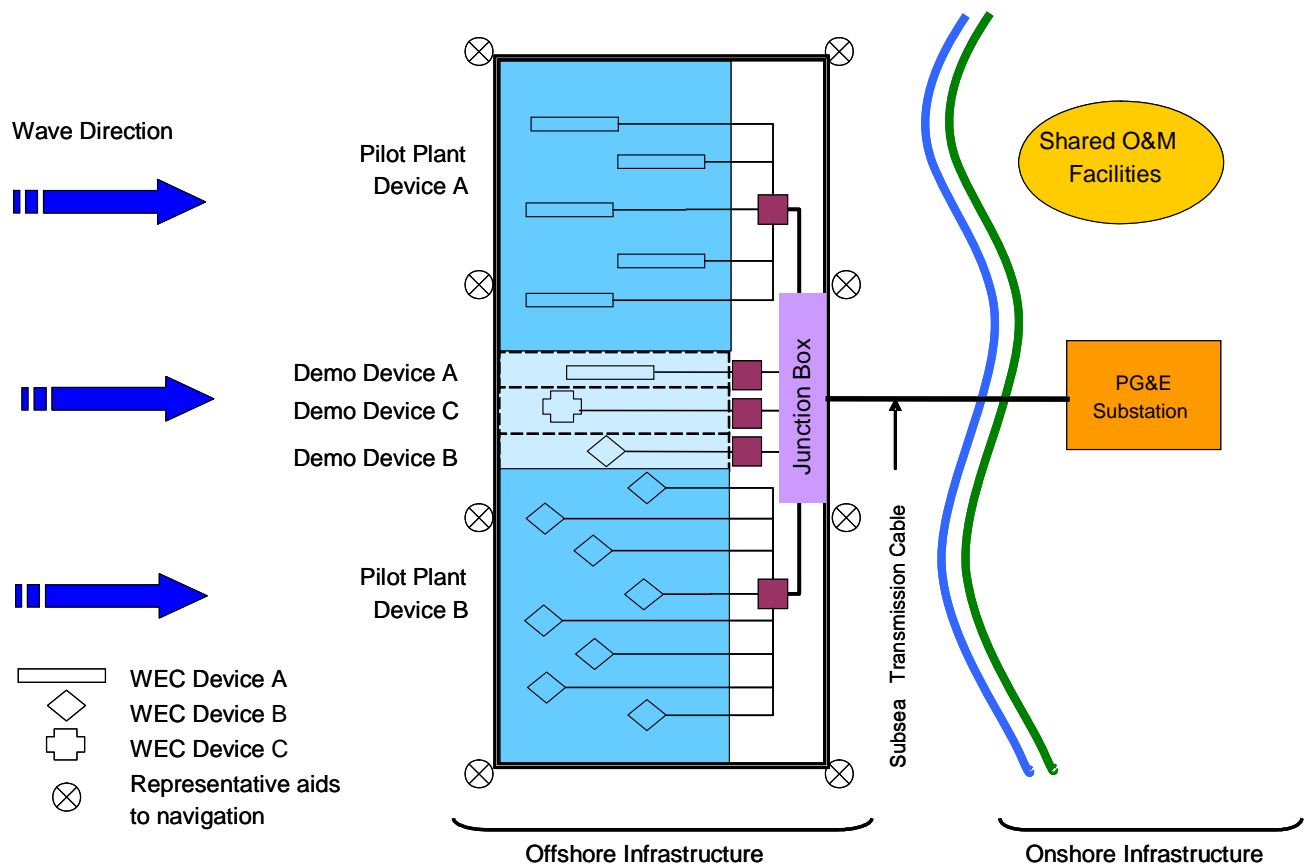

//

The subsea transmission cable will run from the junction box to a landfall site in Eureka. The length of this cable will be determined once the optimal location of the junction box is established, but is expected to be 2 – 6 miles. PG&E will investigate the potential use of an existing wastewater discharge pipe from a pulp and paper mill to bring the cable to shore. If this proves feasible, the transmission cable could be run either within or along the existing pipe, under the beach and inland.

As part of the assessment of project feasibility, PG&E will investigate various options for connecting to the grid. A potential interconnection point is an existing PG&E transmission substation on the Samoa Peninsula on Bay Street, a distance of approximately 0.5 miles from the landside end of the wastewater discharge pipe. The onshore infrastructure will likely include a small command, communication and control station and transformer, circuit breaker and other interconnection equipment dedicated to this project at the existing substation. The exact details of the subsea transmission cable and interconnection such as the capacity, length, and end connection details will be determined during the feasibility study for the proposed project.

The proposed project has the potential of producing 40 MW of electrical power, depending on the technology selected and spacing required, as well as physical, environmental, and regulatory constraints determined during the feasibility studies. Given the early stage of the project analysis and the nascent state of the wave energy industry in the U.S., PG&E is requesting, and will perform a detailed study of, a project area of sufficient size to allow consideration of the many factors that will influence the project's development.

As an example, PG&E understands the project's need to avoid interfering with navigation into and out of Humboldt Bay. The project location map in Exhibit 3 identifies a possible example of a self-imposed exclusion zone (unshaded area) where WEC devices would not be deployed. The area of this exclusion zone is, however, included within the proposed project boundary to allow siting of an interconnecting subsea electrical cable that would connect WEC devices to a junction box not located on their same side of the entrance to Humboldt Bay. The final project build-out area will be determined during feasibility studies and consultation with regulatory agencies, fishermen/crabbers, environmental advocates and other stakeholder groups.

Once PG&E files a development license application, and if FERC grants the project a development license, the deployment of WEC devices is expected to proceed in a phased approach. The first phase will involve the deployment and testing of devices from up to four

different manufacturers yielding a combined nameplate capacity of up to 5MW. PG&E plans to then incrementally expand the project further, up to a capacity of 40MW.

2. Reservoirs.

There are no reservoirs required for this project.

3. Transmission Lines.

The proposed project subsea transmission cable would likely be a 40kV three-phase AC submarine double armored XLPE cable with a fiber core, having roughly a 3.5” diameter. The subsea transmission cable would be buried in the seafloor sediments from the deployment site to shore. A potential landfall for the cable is an existing wastewater discharge pipe from a pulp and paper mill. One potential interconnect option is an existing PG&E substation on Bay Street on the Samoa Peninsula, which is approximately 0.5 miles from the landside end of the wastewater discharge pipe. A preliminary review of the grid infrastructure indicates that 40 MW could be fed into the grid at this location without any major grid upgrades. The exact details of the subsea transmission cable and interconnection such as the capacity, length, and end connection details will be determined during the feasibility study for the proposed project. The proposed project will comply with all interconnection requirements as determined by PG&E and the California Independent System Operator.

4. Estimated Annual Energy Production.

PG&E will initially deploy and test WEC devices from up to four different manufacturers, and up to an installed capacity of 5 MW. PG&E plans to then incrementally expand the project up to 40 MW. PG&E estimates the annual energy output of the 40 MW power plant to be 100,000 MWh/year. This estimate, however, is technology dependent and is subject to change based on the technologies selected.

5. Lands of the U.S.

All lands within the proposed project boundary are identified under Exhibit 3. The aquatic portion of the project would be located on state submerged lands as well as federal waters but not on “lands of the United States” as defined in the Federal Power Act.

6. Public Interest Benefits.

The project will develop a new source of renewable electricity for the public, which:

- A.** Generates clean and renewable energy with minimal effects on the environment given proper care in siting, installation, and operation;
- B.** Provides needed reliable and cost-effective power generation along the California coast;
- C.** Provides added diversification of power generation; and
- D.** Creates local jobs and promotes economic development from the construction, operation, and maintenance of the project.

The proposed project would develop a new source of renewable, non-polluting energy in the U.S. The project will use ocean waves to generate energy in a reliable and environmentally sound way. This indigenous renewable energy resource is also sustainable and does not rely on the consumption of fossil fuel. EPRI recently completed an extensive set of reports on the feasibility of wave energy projects in North America (<http://www.epri.com/oceanenergy>). EPRI identified public benefits of wave energy projects to include job creation (construction, operation, and maintenance of wave power plants), promotion of economic development, and increased energy self-sufficiency.

The Energy Policy Act of 2005 encouraged the development of renewable energy resources, including ocean energy. According to the California Energy Commission, in 2004, 10.2 percent of California's electricity came from renewable resources such as wind, solar, geothermal, biomass, and small hydroelectric facilities. California established its Renewable Portfolio Standard Program in 2002, with the goal of increasing the percentage of renewable energy in the state's electricity mix from these sources to 20 percent by 2017. The Energy Commission's 2003 Integrated Energy Policy Report called for accelerating that goal to 2010, and the 2004 Energy Report Update recommended further increasing the target to 33 percent by 2020. The state's Energy Action Plan also recommended achievement of this goal. The PG&E Humboldt WaveConnect Project will help California reach these goals. Domestic sources of energy are also in the public's best interest as they reduce the country's dependence on foreign oil and other fossil fuels.

EPRI also described wave energy projects as potentially one of the more environmentally benign sources of energy generation given proper care in siting, installation, and operation.

EXHIBIT 2

DESCRIPTION OF PROPOSED STUDIES

1. Description of Studies.

PG&E will consult with appropriate regulatory and resource agencies, Indian tribes, and other Northern California stakeholders to identify important resources in the project area. Through consultation with stakeholders and by reviewing existing information, PG&E will investigate the physical and biological resources of the project area. PG&E anticipates characterizing the existing conditions to develop a baseline from which to assess potential effects that the wave energy project may have on three broad areas: marine life, use of sea space, and coastal processes. As one example, gray whales are an important species that reside and migrate along the California coastline. PG&E will work with regulatory agency staff to understand the migratory patterns of gray whales in the vicinity of the project area and to minimize any potential effects that the construction and operation of the project may have on them. Important existing uses of sea space in the area to consider include both commercial and recreational activities such as shipping, fishing, crabbing, kelp farming, and surfing. Possible effects on coastal processes such as erosion and sediment transport will also be investigated.

Where existing information is insufficient, PG&E may undertake additional studies to ensure that any wave power development would most efficiently utilize the available wave resource to generate electricity while minimizing any potential environmental effects. For example, it's possible that detailed bathymetry and substrate information studies may need to be conducted at the project site in order to ideally locate the WEC devices. PG&E is also planning to investigate transmission capacity, interconnection, and other issues associated with transporting project power to the grid.

WEC projects have been successfully developed and demonstrated around the world, including several in the U.S. The 'Wave Hub' (<http://www.wavehub.co.uk/>) is a project in the United Kingdom that is similar in concept to the proposed PG&E Humboldt WaveConnect project. Portugal recently announced plans for the first-of-its-kind commercial wave energy project and others are planned in Spain, UK, Ireland, South Africa and Australia. This activity is

an indication that wave energy conversion can be commercially and environmentally viable and that WEC device development is at a stage where commercial projects are feasible. In the U.S., several preliminary permit applications for wave energy projects were recently filed with FERC. Further, the Makah Bay Offshore Wave Energy Pilot Project (FERC Project No. 12751) in Washington State was the first wave energy project to file a license application with FERC in November 2006.

Information available from previous and ongoing wave energy projects worldwide will be used to support the design and development of the PG&E Humboldt WaveConnect Project and in the evaluation and selection of appropriate WEC devices.

PG&E will also conduct economic and financial feasibility analyses for the proposed project. The following is a proposed schedule for the project:

***Schedule To Commence Once Regulatory Approvals Are Received.
Schedule Assumes Timing and Activities Based on
PG&E's Preliminary Analysis and Is Subject To Revision.***

Year 1	<p><u>Initial Assessment</u></p> <ul style="list-style-type: none"> • Begin discussions with stakeholders • Begin wave resource studies • Perform initial siting analysis including bathymetry studies and identification of other constraints • Identify preliminary short list of deployment sites within permitted area • Identify early environmental studies and begin preliminary work on those <p><u>Detailed Assessment (subsequent)</u></p> <ul style="list-style-type: none"> • Continue detailed discussions with stakeholders • Conduct detailed resource analysis • Identify and quantify site constraints • Develop construction and interconnection strategy for potential sites • Begin WEC device evaluation • Continue and expand environmental studies • Develop energy yield analysis • Develop initial financial models • Compile information for and file NOI/PAD
--------	---

Years 2 and 3	<p>License Application Development</p> <ul style="list-style-type: none"> • Continue discussions with stakeholders • Finalize technology selection and designs • Perform technology testing • Continue environmental and other studies to support license application • File license application
---------------	---

PG&E acknowledges and supports the recent Notice of Inquiry and Interim Statement of Policy regarding Preliminary Permits for Wave, Current, and Instream New Technology Hydropower Projects, issued February 15, 2007 (Docket No. RM07-08-000), and intends to fully comply with all requirements imposed by the Commission under its “strict scrutiny” approach to ensure appropriate progress under the permit.

2. Need for New Roads.

This project will not require the construction of any roads.

3. Dam Construction.

The project will not require the construction of any type of dam as the facility is designed to operate in the open ocean and capture the heaving motion of the ocean swell.

4. Waiver.

No waiver is being sought at this time for the evaluation and testing of the feasibility of the project.

5. Statement of Costs and Financing.

PG&E estimates that during the preliminary permit period, studies, investigations, tests, surveys, maps, plans, and other related specifications for the proposed project will cost approximately between \$1,000,000 and \$3,000,000 and will be funded by PG&E, subject to regulatory approval by the California Public Utilities Commission.

//

//

PG&E Humboldt WaveConnect Project

Permit application boundary shows proposed area of investigation. Actual project would occupy smaller area. Possible footprints of 5MW and 40MW projects are shown below for reference.

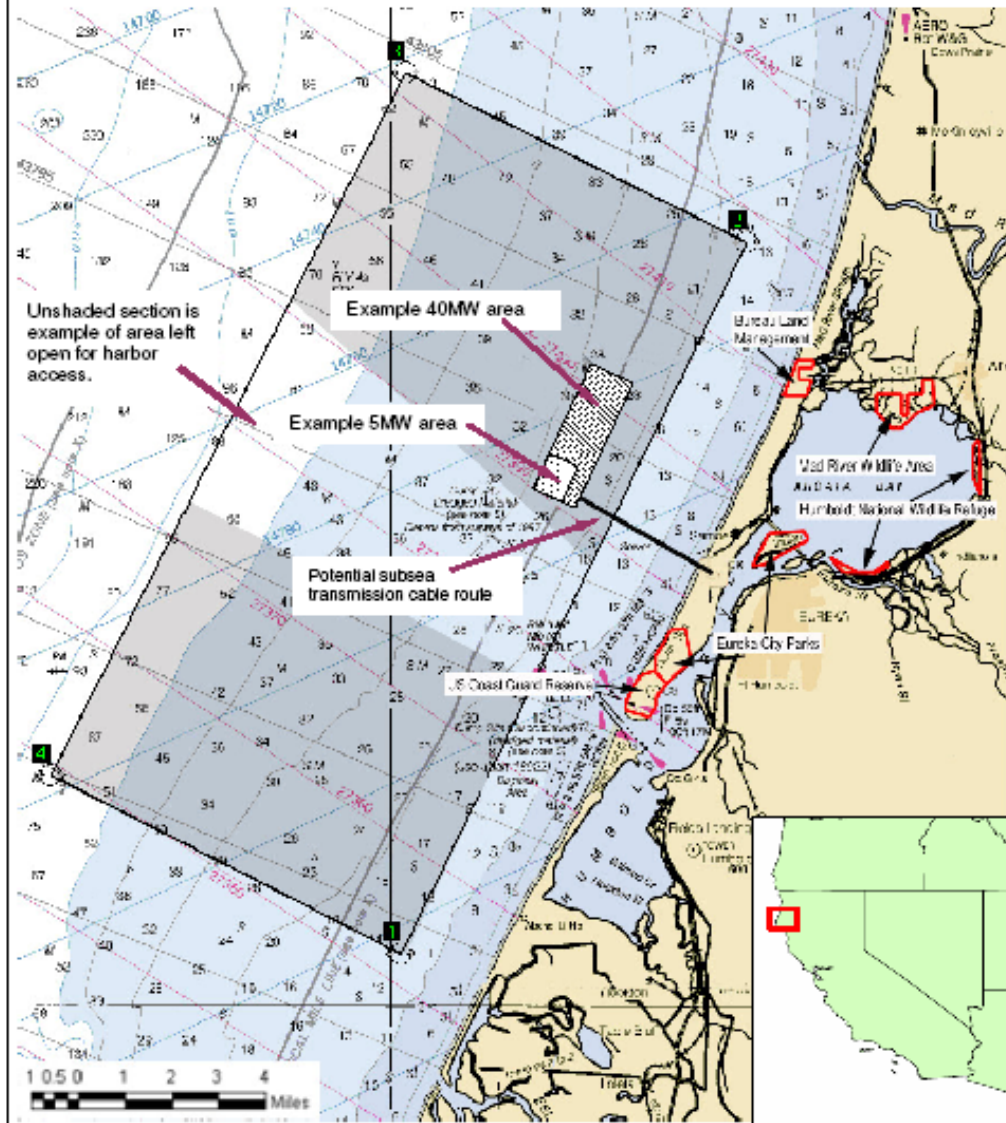

Water depth in fathoms: 1 fathom = 6 feet
Source: NOAA chart # 18620

SECTION 4.32
INFORMATION

1. PG&E is the only entity that has or intends to obtain and will maintain any proprietary rights necessary to construct, operate, or maintain the proposed property as described in this application.

2. Municipal Information.

No federal facilities would be used by the proposed project. The area proposed for evaluation and testing is located within, or in the ocean water immediately adjacent to, one county:

Humboldt County
825 Fifth Street, Room 111
Eureka, CA 95501-1107

3. Cities or Towns Where Project Will Be Located.

Eureka:

Eureka City Hall
531 "K" Street
Eureka, CA 95501-1146

Arcata:

Arcata City Hall
736 "F" Street
Arcata, CA 95521-6211

No dam is proposed in association with this wave energy project. Those cities and towns with a population of 5,000 or more that lie within 15 miles of the proposed evaluation and study area include:

City of Eureka
Population 26,128, Census 2000
Eureka City Hall
531 "K" Street
Eureka, CA 95501-1146

//

City of Arcata
Population 16,651, Census 2000
Arcata City Hall
736 "F" Street
Arcata, CA 95521-6211

City of Fortuna
Population 10,497, Census 2000
Fortuna City Hall
P.O. Box 545
Fortuna, CA 95540-0545

4. No federal facilities would be used by or otherwise associated with the proposed project, and no special purpose political subdivisions exist within the proposed project boundary for the evaluation and testing of wave energy potential.

No other known political subdivisions exist within the proposed project evaluation and test area; however, PG&E will consult with all agencies and organizations with regulatory authority over the waters and resources of the proposed project area during the evaluation of project feasibility.

5. Indian Tribes (Reservations) That May Be Affected By The Project.

Big Lagoon Rancheria
P. O. Drawer 3060
Trinidad, CA 95570-3060
Telephone: (707) 826-2079
Facsimile: (707) 826-1737

Trinidad Rancheria
P. O. Box 630
Trinidad, CA 95570-0630
Telephone: (707) 677-0211
Facsimile: (707) 677-3921

Table Bluff Rancheria
P. O. Box 519
Loleta, CA 95551-0519
Telephone: (707) 733-5055
Facsimile: (707) 733-5601

Hoopa Valley Tribal Council
P. O. Box 1348
Hoopa, CA 95546-1348
Telephone: (916) 625-4211
Facsimile: (916) 625-4594

Blue Lake Rancheria
P. O. Box 428
Blue Lake, CA 95525-0428
Telephone: (707) 668-5101
Facsimile: (707) 668-4272

Northern California Agency
Bureau of Indian Affairs
P. O. Box 494879
Redding, CA 96049-4879
Telephone: (916) 246-5141
Facsimile: (916) 246-5167

VERIFICATION STATEMENT

This Application for a Preliminary Permit for the PG&E Humboldt WaveConnect Project is executed in the State of California, City and County of San Francisco.

Roy Kuga, Vice President - Energy Supply of Pacific Gas and Electric Company located at 245 Market Street, San Francisco, California, being duly sworn, deposes and says that the contents of this Preliminary Permit Application are true to the best of his knowledge or belief.

The undersigned Applicant has signed the Application on this _____ day of _____, 2007.

By: _____
ROY KUGA

Subscribed and sworn before me, a Notary Public of the State of California, County of San Francisco, this _____ day of _____, 2007.

NOTARY PUBLIC