

## PERFORMANCE GROUNDING AND WIRING FOR SENSITIVE EQUIPMENT

### *Introduction*

Many power quality variations that occur within customer facilities are related to wiring and grounding problems. It is estimated that these problems account for up to 80% of all power quality problems within a facility. Typical power system problems that can cause malfunction or failure of electronic equipment relate to improper grounding design, inadequate power distribution (wiring) design, electrical noise, and AC voltage quality.

This Power Note attempts to present an overview of major concerns associated with electronic equipment power and grounding requirements. Topics that are addressed include –

1. Grounding design basics.
2. NEC grounding requirements.
3. Types of system and equipment grounding.
4. Safe grounding practices.
5. Guidance beyond the NEC requirements on establishing maximum performance associated with electronic equipment grounding (a function vital to the proper operation of electronic equipment).

### *Definitions*

Grounding is one of the most important and least understood aspects of the entire electrical system. When the word “ground” is mentioned, people normally think of a connection to a water pipe or ground rod. Hence, some of the key definitions of wiring and grounding terms from the 2002 National Electrical Code (NEC) include –

**Ground.** A conducting connection, whether intentional or accidental, between an electrical circuit or equipment and the earth or to some conducting body that serves in place of the earth.

**Grounded.** Connected to earth or to some conducting body that serves in place of the earth.

**Grounded, Effectively.** Intentionally connected to earth through a ground connection or connections of sufficiently low impedance and having sufficient current-carrying capacity to prevent the buildup of voltages that may result in undue hazards to connected equipment or to persons.

**Grounded Conductor.** A system or circuit conductor that is intentionally grounded. This is also known as the neutral wire.

**Grounding Conductor.** A conductor used to connect equipment or the grounded circuit of a wiring system to a grounding electrode or electrodes.

**Grounded Conductor, Equipment.** The conductor used to connect the non-current carrying metal parts of equipment, raceways, and other enclosures to the system grounded conductor, the grounding electrode conductor, or both, at the service equipment or at the source of a separately derived system.

**Grounding Electrode Conductor.** The conductor used to connect the grounding electrode(s) to the equipment grounding conductor, to the grounded conductor, or to both, at the service, at each building or structure where supplied from a common service, or at the source of a separately derived system.

Grounding of electrical systems and equipment can be divided into two areas:

1.) **System Grounding**, and 2.) **Equipment Grounding**. These two areas are often interchanged and the resultant misapplication of system and equipment grounding practices can lead to a system that is expensive, inefficient, and even unsafe. They are kept separate from each other except at the point where they receive their source of power, such as at the service equipment or at a separately derived system. The various components that make up the system and equipment grounding systems are illustrated in **Figure 1**.

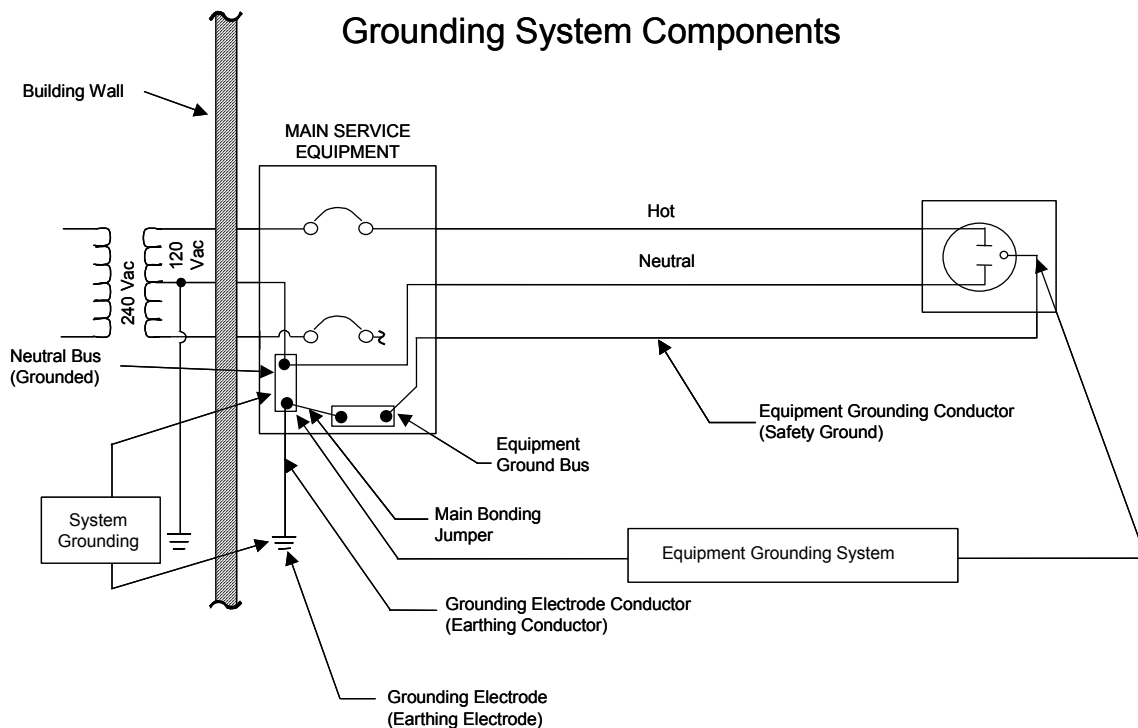

Figure 1 – Various components of the system and equipment grounding

There are three basic reasons for grounding AC power systems:

- 1.) To limit the voltages caused by lightning or by accidental contact of the supply conductors with conductors of higher voltage.
- 2.) To stabilize the voltage under normal operating conditions (which maintains the voltage at one level relative to ground, so that any equipment connected to the system will be subject only to that potential difference).
- 3.) To facilitate the operation of overcurrent devices, such as fuses, circuit breakers, or relays, under ground-fault conditions.

## **System Grounding**

The purpose of system grounding is to protect the electrical system and equipment from super-imposed voltages caused by lightning and accidental contact with higher voltage systems. System grounding is also required to prevent the build-up of static charges on equipment and materials. An additional purpose of system grounding is to establish a zero-voltage reference point for the system. This is important to ensure proper equipment performance.

The ground electrode provides the electrical connection from the power system ground to earth. The item of primary interest in evaluating the adequacy of the ground electrode is the resistance of this connection. There are three components in a ground electrode:

- 1.) **Electrode resistance.** Resistance due to the physical connection of the grounding wire to the grounding electrode.
- 2.) **Rod-earth contact resistance.** Resistance due to the interface between the soil and the electrode.
- 3.) **Ground resistance.** Resistance due to the resistivity of the soil in the vicinity of the grounding electrode.

The resistance of the ground electrode connection is important because it influences transient voltage levels during switching events and lightning transients. Studies have shown that the majority of the resistance of a grounding electrode is comprised of the body of earth surrounding the electrode.

The body of earth can be broken into several concentric “shells” of earth surrounding the electrode. The shells close to the electrode have a small cross-sectional area and exhibit a relatively high resistance. As more shells are added, each succeeding shell has a larger cross-sectional area and a lower resistance.

## **Equipment Grounding**

In contrast to system grounding, the purpose of equipment grounding is to assure that all exposed non-current carrying conductive surfaces such as equipment enclosures, conduits, raceways, etc. are effectively interconnected and tied to earth. The objectives achieved by effective equipment grounding are –

- 1.) To minimize to the greatest extent possible the appearance of any voltages on equipment enclosures. This will provide protection from serious shock and/or electrocution to personnel in contact with the enclosure.
- 2.) To provide an intentional path of ample current carrying capacity and low impedance that will carry sufficient fault current to ensure rapid operation of the circuit overcurrent protective device under ground fault conditions.
- 3.) To establish and maintain a zero-voltage reference point that will contribute to the proper operation of data processing, solid-state process control systems, computer-controlled machinery, and other sensitive electronic equipment.

During a fault condition in electrical and electronic equipment, grounding provides a return path for fault current to trip the assigned circuit breaker. Requirements established by the NEC attempt to ensure that enough current flow would exist to trip the breaker. In the 2002 NEC, both Article 250-4(A)(5) and 250-4(B)(4) for grounded and ungrounded systems respectively contain fault current path objectives. For equipment grounding – the path to ground from circuits, equipment and conductor enclosures to be effective:

Grounded Systems -“Electrical equipment and wiring and other electrically conductive material likely to become energized shall be installed in a manner that creates a permanent, low-impedance circuit capable of safely carrying the maximum ground-fault current likely to be imposed on it from any point on the wiring system where a ground fault may occur to the electrical supply source.”

Ungrounded Systems – “Electrical equipment, wiring, and other electrically conductive material likely to become energized shall be installed in a manner that creates a permanent, low-impedance circuit from any point on the wiring system to the electrical supply source to facilitate the operation of overcurrent devices should a second fault occur on the wiring system”.

For further information on general requirements for grounding and bonding, refer to Article 250.4 of the 2002 NEC.

### ***Service Entrance Connections***

Installing AC quality correction equipment such as conditioners does nothing to correct grounding and wiring problems, since the AC power line monitors used to identify quality problems are not designed to identify grounding and wiring errors. To prevent wasting time, money, and other resources, grounding design and power distribution problems must be located and corrected first.

The primary components of a properly grounded system are found at the main service entrance. The neutral point of the supply power system is connected to the grounded conductor (neutral wire) at this point. This is also the only location in the system (except in the case of a separately derived system, i.e. isolation transformer) where the grounded conductor (neutral wire) is connected to the ground conductor (green wire) via the main bonding jumper. The ground conductor is also connected to the building grounding electrode via the grounding electrode conductor at the main service entrance.

Throughout the system, a safety ground must be maintained to ensure that all exposed conductors that may be touched are kept at an equal potential. This safety ground also provides a ground fault return path to the point where the power source neutral conductor is grounded. The safety ground can consist of suitable metal conduit or the metal conduit and a separate conductor (ground conductor or green wire) in the conduit. This safety ground originates at the main service entrance and is carried throughout the building.

### Safe Grounding Practices

To avoid improper installations that result in unsafe grounding for personnel and system components, all electrical equipment within a building facility should be referenced to earth and terminated at a single point, commonly known as single-point grounding. This point is usually the service entrance ground connection and is located at the secondary of the service transformer. It is the most widely accepted design to incorporate into the grounding system for effectiveness and safety. The potential differences between any equipment are minimized and thus, avoiding a serious safety hazard. This is equally important to ensure proper transmission and reception of data over communication lines. A ground system with multi-ground points can create multi-ground loops and impose stray currents on the logic of microprocessors.

The example shown in **Figure 2** shows the effect of two earth reference points. In this case, there is a potential difference of 5 volts between the Equipments A and B.

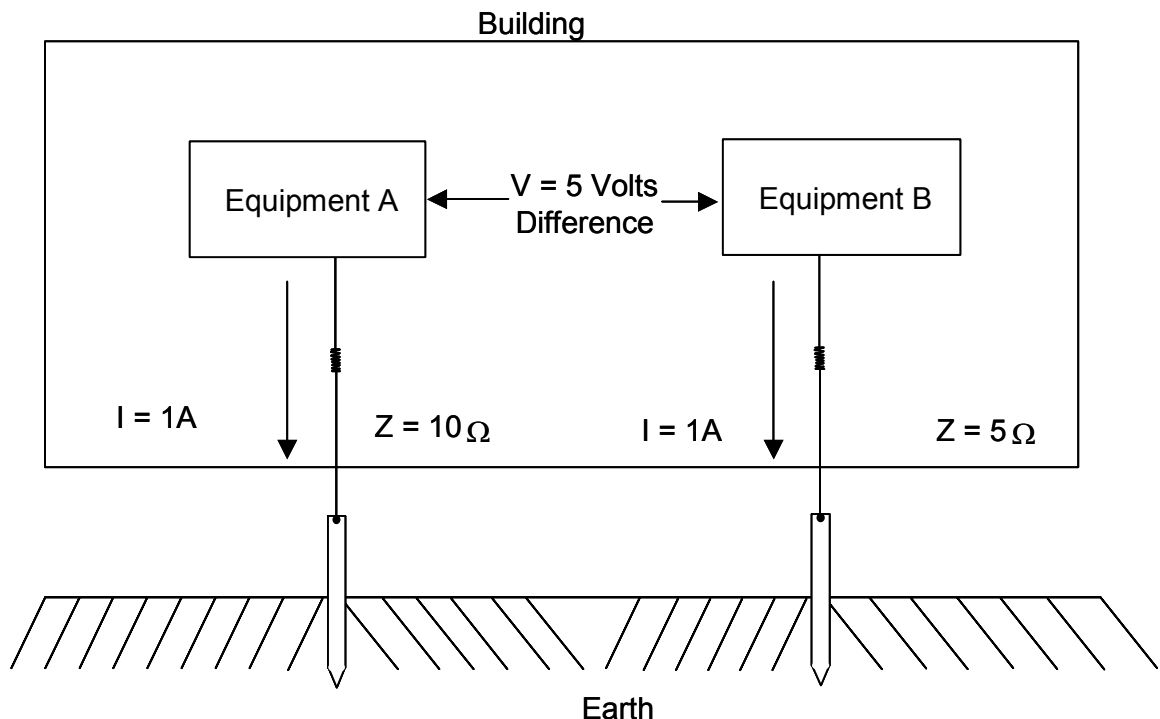
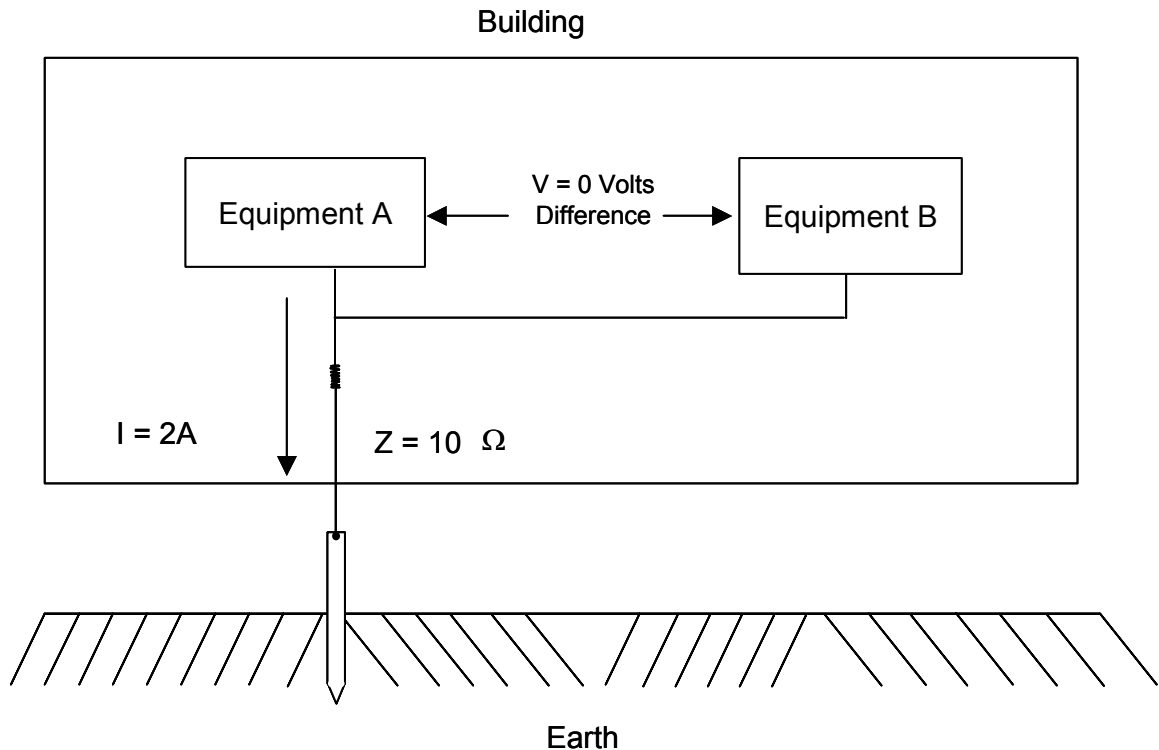

Figure 2 – Effect of two earth reference points

On the other hand, if all equipment is referenced to a single point as shown in **Figure 3**, the voltage difference between Equipments A and B is reduced to 0 volts.



*Figure 3 – Single-point reference of all equipment*

### **Unsafe Grounding**

Sometimes a computer system is found connected to a “clean ground” that happens to be a ground rod driven into the earth through the computer room floor. This type of grounding – the use of more than one earth reference point – presents a serious safety hazard as illustrated in **Figure 4**. As shown, when a fault occurs in the equipment, the impedance of the ground path will limit the fault current in this example to only 3 amps. The overcurrent device will not trip due to this condition. Furthermore, the equipment case will be energized at 120 volts.

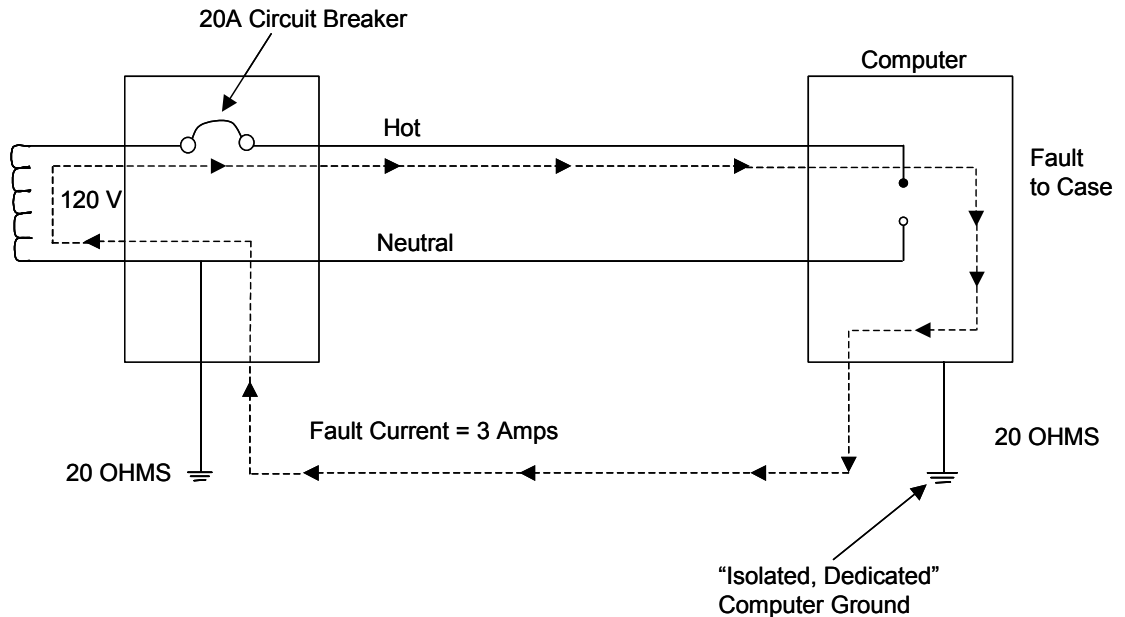

Figure 4 – Unsafe “Isolated” Computer Ground

To properly and safely ground the computer, an isolated ground where a separate equipment-grounding conductor (green wire) must be run in the same conduit as the supply conductors and terminated at the ground bus in the main service. This will provide a low-impedance path for fault currents to return to the source and will meet the safety requirements of the NEC.

**Figure 5** illustrates the proper method for grounding the computer.

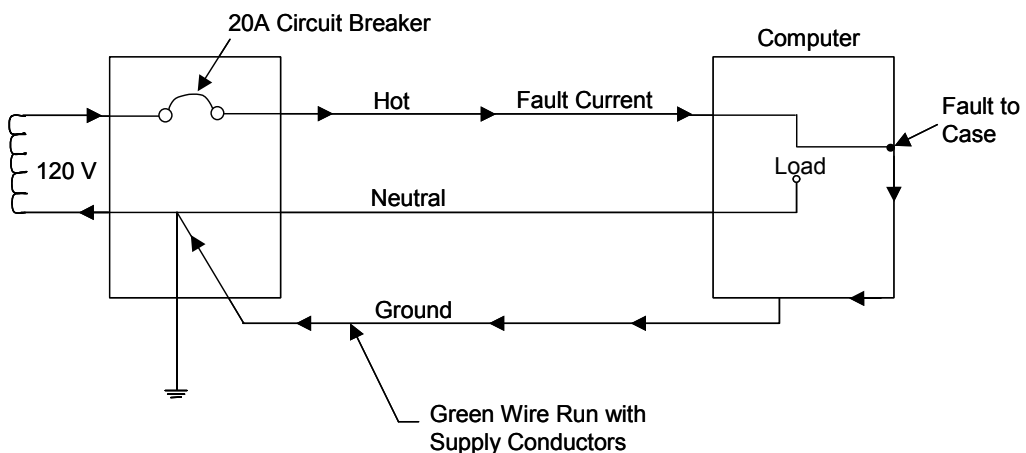

Figure 5 – Proper method for grounding the computer

As mentioned earlier, unless there is a separately derived system, the only neutral-to-ground bond via the main bonding jumper should be at the main service entrance. Downstream neutral-to-ground bonds result in parallel paths for the load return current where one of the paths becomes the ground circuit. During a fault condition, the fault current will split between the ground and the neutral, which could prevent proper operation of protective devices and thus creating a serious shock hazard. **Figure 6** illustrates the hazards created by an unintentional neutral-ground "short" condition. In the example shown, a neutral-ground short has occurred in the branch circuit panel board. If the impedance of the neutral and safety ground are each 1 ohm and the total load current is 50 amps, the return current will divide equally at the neutral-ground short with 25 amps flowing on both the neutral and safety ground. This will cause a potential of 25 volts above ground to appear on all equipment that is served from the branch circuit panel board.

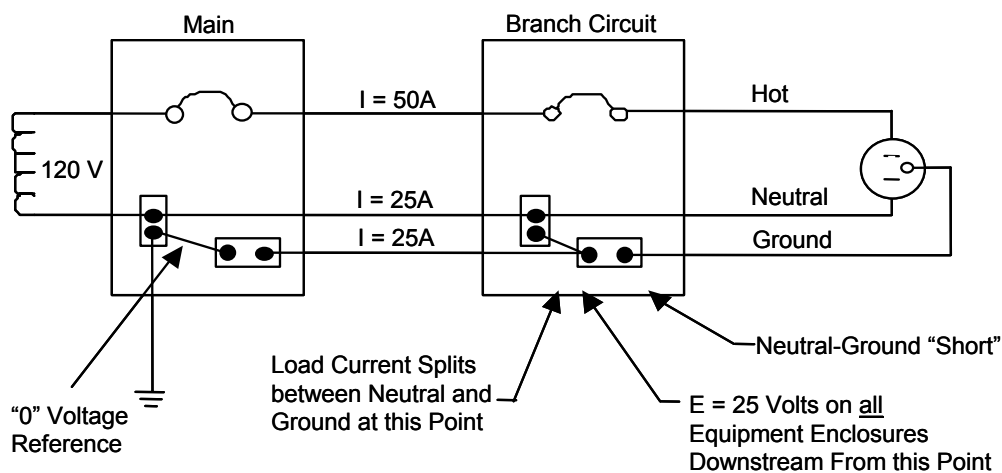

Figure 6 – Neutral-Ground "Short" Condition

## Wiring And Grounding For Performance

It should be noted that the primary purpose of grounding in AC power systems is equipment and personnel safety. The NEC provides the minimum requirements for wiring and grounding. The secondary purpose of grounding in AC power systems for sensitive electronic equipment is equipment performance. It is often necessary to go beyond the NEC requirements to achieve a system that also minimizes the impact of power quality variations on connected equipment. However, the performance purpose of grounding can never take precedence over the safety purposes.

Two important areas of concern regarding equipment performance is the conductor size of the neutrals and grounds.

In a 3 $\phi$  wye-connected secondary power system, 208/120V or 480/277V, with balanced and linear loads, the current flow in the neutral conductor will be practically 0 amps. Therefore, it is a common practice to "daisy chain" or jumper together the neutrals for 208/120V circuits. This wiring technique reduces the installation costs for labor and material. Article 220.22 of the 2002 NEC allows the reduction of the neutral conductor size under specific conditions of use.

However, many computers and other related electronic systems today use switching type power supplies. The series pass element in these power supplies is a pulse-width-modulation (PWM) switching element. The input current of a switching supply is illustrated in **Figure 7**. As the load increases and decreases, the PWM circuit adjusts the trigger point on the sine wave accordingly. When several loads with switching power supplies are served, a balanced load on all three phases of a 208/120V system will not reduce the neutral current to practically 0 amps. This is a critical point to remember when specifying power distribution wiring for loads with switching power supplies. Therefore, the neutral and hot conductors should be the same physical size and each load should have a separate neutral conductor (no daisy chaining) when serving loads with switching power supplies.

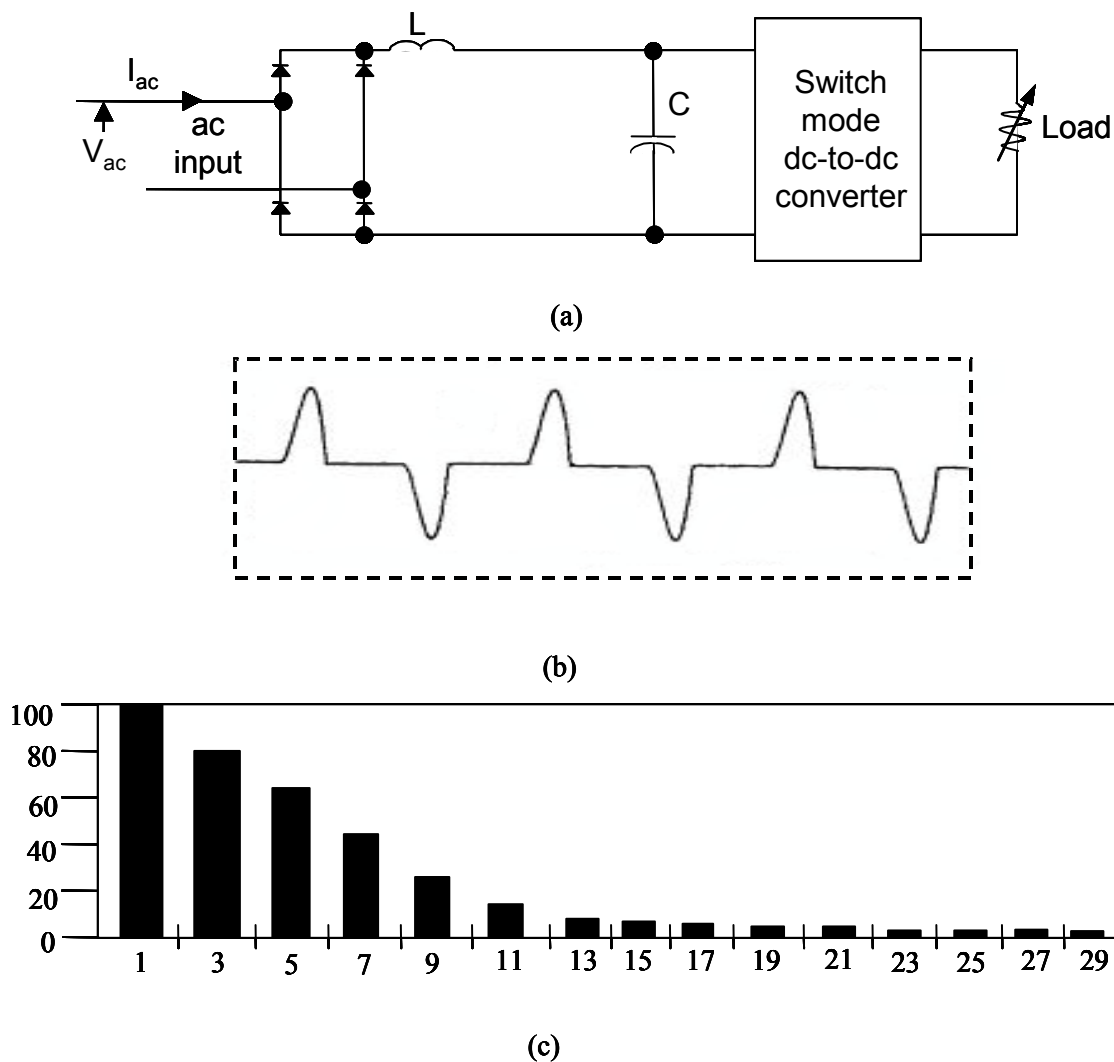

Figure 7: Circuit diagram and input current of an ordinary PC switch-mode power supply. (a) Electronic appliance power supply circuit. (b) Inout current,  $I_{ac}$  waveform and spectrum. (c) Frequency spectrum of input current.

Article 220.22 in the 2002 NEC describes the basis for calculating the neutral load of feeders or services as the maximum unbalanced load that can occur between the neutral and any other ungrounded conductor.

If the system also supplies nonlinear loads such as electric-discharge lighting, including fluorescent and high intensity discharge (HID), or data-processing or similar equipment, the **neutral is considered a current-carrying** conductor if the electric-discharge lighting, data-processing, or similar equipment load on the feeder neutral consists of **more than half** the total load. Electric-discharge lighting and data-processing equipment may have harmonic currents in the neutral that may exceed the load current in the ungrounded conductors. It would be appropriate to require a full-size or larger feeder neutral conductor, depending on the total harmonic distortion contributed by the equipment to be supplied (see Section 220.22, FPN No. 2). In some instances, the neutral current may exceed the current in the phase conductors.

To exceed NEC minimum requirements beyond safety for equipment performance, the grounding electrode conductor is sized based on guidelines in the NEC (Section 250.66). **Table 250.66** of the 2002 NEC included below provides the minimum size of the grounding electrode conductor for AC systems.

*Table 250-66, Grounding Electrode Conductor for AC Systems*

Size of Largest Service-Entrance Conductor or Equivalent Area for Parallel Conductors		Size of Grounding Electrode Conductor	
Copper	Aluminum or Copper-Clad Aluminum	Copper	*Aluminum or Copper-Clad Aluminum
2 or smaller	0 or smaller	8	6
1 or 0	2/0 or 3/0	6	4
2/0 or 3/0	4/0 or 250 MCM	4	2
Over 3/0 thru 350 MCM	Over 250 MCM thru 500 MCM	2	0
Over 350 MCM thru 600 MCM	Over 500 MCM thru 900 MCM	0	3/0
Over 600 MCM thru 1100 MCM	Over 900 MCM thru 1750 MCM	2/0	4/0
Over 1100	Over 1750 MCM	3/0	250 MCM

In addition, **Table 250-122** of the 2002 NEC included below provides the minimum sizes for equipment grounding conductors (safety grounds) for circuits and equipment.

*Table 250-122. Minimum Size Equipment Grounding Conductor for Grounding Raceway and Equipment*

Rating or Setting of automatic Overcurrent Device in Circuit ahead of Equipment, Conduit, etc., Not Exceeding (Amperes)	Copper Wire No.	Aluminum or Copper-Clad Aluminum Wire No.*
15	14	12
20	12	10
30	10	8
40	10	8
60	10	8
100	8	6
200	6	4
300	4	2
400	3	1
500	2	1/0
600	1	2/0
800	0	3/0
1000	2/0	4/0
1200	3/0	250 MCM
1600	4/0	350 MCM
2000	250 MCM	400 MCM
2500	350 MCM	600 MCM
3000	400 MCM	600 MCM
4000	500 MCM	800 MCM
5000	700 MCM	1200 MCM
6000	800 MCM	1200 MCM

## Isolated Grounding

One type of power disturbance that can be particularly troublesome to control is electrical noise (electromagnetic interference). Electrical noise is any unwanted signal that is common to all circuit conductors simultaneously. In AC power systems, the difference in potential between neutral and ground is one form of electrical noise, since any change in neutral potential relative to ground also affects all of the other power circuit conductor potentials to ground. If the ground paths of individual pieces of equipment are not isolated from one another, currents carried on one may affect another's operation. The primary objective of grounding for noise control is to create an equipotential ground system. Potential differences between different ground locations can stress insulation, create circulating ground currents in low-voltage cables and interfere with sensitive equipment that may be grounded in multiple locations.

The noise performance of the supply to sensitive loads can sometimes be improved by providing an isolated ground to the load. This is done using isolated ground receptacles, which are identified by an orange triangular "▼" marking located on the face of the receptacle. If an isolated ground receptacle is being used downline from the panel board, the isolated ground conductor is not connected to the conduit or enclosure in the panel board, but only to the ground conductor (green wire) of the supply circuit as shown in **Figure 8**.

The metal conduit is the safety ground in this case and is connected to the enclosure.

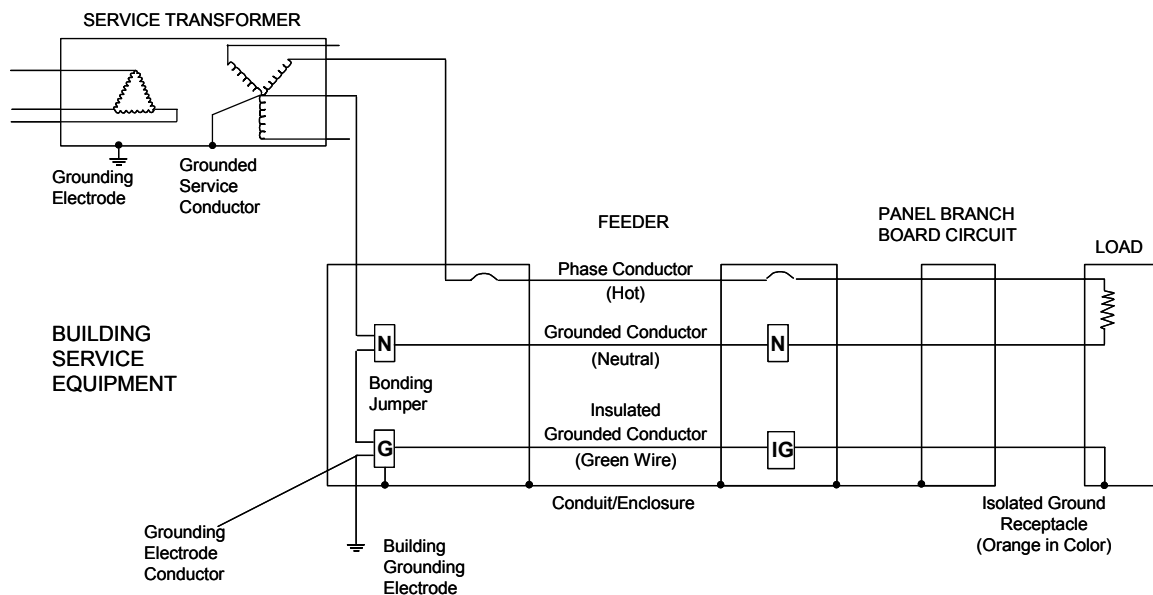

Figure 8 – Grounding configuration for an isolated ground

This receptacle does not have the ground conductor connected to the receptacle enclosure or conduit. The isolated ground conductor may pass through one or more panel boards without connection to local ground until grounded at the main service entrance or other separately derived ground. The use of isolated ground receptacles requires careful wiring practices to avoid unintentional connections between the isolated ground and the safety ground. When using an insulated ground wire, be sure that it is an insulated green wire with a yellow striping or similar method to identify it as unique. It is important to keep separate from the grounding conductor as to not compromise the integrity of the grounding system.

### **Thinking Beyond The NEC**

The Code's purpose is to ensure safety. It has only recently begun to address power quality issues. To avoid power quality problems, the recommended practices and references published in IEEE 1100 (*The Emerald Book*), IEEE 142 (*The Green Book*), and *Soares Book on Grounding* are good starting points.

Based on those sources, the following practices are appropriate for any installation with equipment that may be sensitive to noise or disturbances introduced due to coupling in the ground system:

- Whenever possible, use individual branch circuits to power sensitive equipment. Install no more than three to six outlets per branch circuit that serve computers and other sensitive electronic equipment. Segregate outlets that serve computer equipment from those used for general service (separate panel boards and feeders are also recommended.)
- Use oversized conductors to account for peak loads, since those loads may be up to three times that of RMS current levels when power is severely distorted. This practice also reduces energy ( $I^2R$ ) losses.
- As mentioned earlier, specify oversized neutrals in three-phase circuits feeding nonlinear-load branch circuits. Better still, use separate full-sized neutrals for each phase leg.
- Don't rely on conduit or raceways as equipment-grounding conductors. Instead, include a separate copper grounding conductor (green wire) for each circuit. Follow recommendations spelled out in IEEE 1100. Above all, make sure all systems are properly bonded to a common grounding electrode system. Note: Conduit fittings and connectors may have minimal contact area and be subject to corrosion and loss of contact.
- Verify that the grounding electrode system indicates a resistance no greater than 10 ohms, less in installations that contain computers and other sensitive electronic equipment. (Most computer equipment manufacturers now recommend 2 ohms maximum ground resistance.)
- Green-wire grounds should be the same size as the current-carrying conductors, and the individual circuit conduit should be bonded at both ends.
- Section 250.96(A) of the 2002 NEC requires that bonding be done around connections of metal raceways, cable trays, cable sheaths, enclosures, frames, fittings and other metal noncurrent-carrying parts used as equipment grounding conductors where necessary. This may be necessary to assure that these systems have electrical continuity and the current-carrying capacity to safely conduct the fault current likely to be imposed on them.

- Section 250-96(A) also refers to conditions where a non-conducting coating (paint) might interrupt the required continuity of the ground-fault path, and it points out that such coatings must be removed unless the fitting(s) is (are) designed as to make such removal unnecessary.
- One of the most common wiring problems is a loose fitting or connector. A compression fitting is preferable to a set screw. A double lug fitting is preferable to a single lug. All aluminum fittings and/or connectors should be used with “oxide inhibitor” grease.
- Due to the fact that conductors and fittings will expand under load and contract with no load, the continuous expansion/contraction cycle can eventually result in a loose connection. This is especially important for main feeders and large loads. These connections should be re-torqued regularly. Infrading in between torquing can reduce the occurrence of loose connections. Aluminum has a much higher coefficient of expansion than does copper. It is important to always be aware when using copper vs. aluminum rated connectors.
- Keep in mind that the best laid plans to grounding can be compromised when end-users by mistake inject offending loads, i.e., vacuum cleaner, microwave ovens, etc., to the original purpose of grounding a special or sensitive load(s).

As connections age, they loosen, corrode and become subject to thermal stress that can increase the impedance of the equipment ground path or increase the resistance of this connection to earth. Two procedures help to ensure that electronic equipment is verified properly. The first procedure involves educating those responsible for sensitive building operations as to the correct way of protecting electronic equipment. The second procedure involves the development of testing and maintenance programs to maintain levels of performance and reliability of a building’s electrical power grounding system for electronic equipment.

The table below summarizes some of the new wiring practices recommended to achieve a high level of power quality. Many of the “before” practices are still reflected in building codes today.

## POWER QUALITY WIRING AND GROUNDING ISSUES AND RECOMMENDATIONS

	Old Practice or Code Minimum	Helpful Procedures or Recommended Practice Now
Receptacle outlets per 20 amp circuit	13	3 to 6
Neutrals	Full size or downsized neutral (on 3-phase systems)	Use double size neutral (CBEMA) or larger
	One neutral share among equipment (single phase branches)	Use separate full size neutral for each phase, back to panel
Phase Conductors	Standard phase conductor sizing per Code	Use upsized phase conductors to minimize voltage fluctuations
Circuits	Can be shared among many outlets and uses	Use separate circuits for harmonic-and/or transient sensitive loads
Grounding	Can use metal conduit as grounding conductor	Use separate insulated copper wire as grounding conductor
	Downsized grounding conductor	Use full size or upsize grounding conductor
	(Commercial/Industrial) Must use metal water pipe, metal building frame, and a concrete-encased electrode (if available)	Use a copper ground ring and multiple interconnected ground rods
	Use a second ground rod if first is over 25 ohms (no resistance measurement required)	Use multiple rods or ground ring and measure to ensure low resistance to ground
	Access floor used for equipotential grid in computer mainframe room	Use copper system for equipotential grid
	No lightning or surge protection	Use lightning and surge protection
Other Equipment	Standard rated transformers, circuit breakers, and panels	Use harmonic-rated transformers, circuit breakers, and panels
	Use standard size neutral and ground buses in panel boards	Use 200% rated neutral and ground buses where electronic loads are present

Source: Copper Development Association, A6001-95/96

This document has been produced for the use of qualified individuals involved in the design and installation of electric systems. Recognizing that each system must be designed and installed to meet particular circumstances, CDA assumes no responsibility or liability of any kind in connection with this document or its use by any person or organization and makes no representations or warranties of any kind hereby. A bibliography of references texts on this topic, as well as other education materials, are available from CDA. Please call (800) CDA-DATA, or visit our Web site.

## **Bibliography**

- 1.) National Electrical Code (NEC) 2002 Handbook, Ninth Edition, Copyright 2002, National Fire Protection Association, Inc.
- 2.) IEEE Standard 1100-1999, Recommended Practice for Powering and Grounding Sensitive Electronic Equipment (IEEE Emerald Book).
- 3.) IEEE Standard 142-1991, Recommended Practice for Grounding of Industrial and Commercial Power Systems (IEEE Green Book).
- 4.) Soares Book on Grounding, Seventh Edition, Copyright 1999, International Association of Electrical Inspectors.
- 5.) Electrical Power Systems Quality, Second Edition, Copyright 2003, The McGraw-Hill Companies, Inc.
- 6.) Copper Development Association, Inc; Website: [www.copper.org](http://www.copper.org)