



# **Apprentice Electrical Technician Test (ETT)**

## **Preparation Guide**

---

# APPRENTICE ELECTRICAL TECHNICIAN TEST (ETT)

## About the Test

There are 40 questions with a maximum time limit of three hours. This is a closed book test and calculators are allowed. Seventy percent (70%) score is required to qualify.

## Reference Materials

ETT test contains questions on the following:

- electrical theory
- power and current transformers
- electronics theory
- electrical drawings

A general reference book is always invaluable as a supplement to other textbooks from classes or specific subjects, and as an instrument for general review in preparing for qualifying tests. Additional resources for improving understanding of the concepts listed above may be found at your local libraries and bookstores.

We hope you find this information helpful. Make sure that when you are scheduled to take the test you are physically and mentally alert and ready to do your best, or you should reschedule your appointment.

Pacific Gas and Electric Company wishes you the best of luck in qualifying on our test.

## **Sample Questions**

Attachment 1 contains sample questions for the person to have some idea of what to expect. It, by no means, is a complete test and is only a tool for the person to determine how much preparation is needed.

## **Materials Covered on the Test**

### **1. Electrical Theory - 19 questions**

- a. Properties of DC and AC voltage, current, and power
- b. The AC sine wave
- c. AC voltage and current polarities
- d. AC conversions of rms, peak, and peak-to-peak voltages
- e. Math prefixes and symbols, such as mega, kilo, milli, and micro
- f. Convert cycles to seconds or visa versa
- g. Electrical units of measurement, such as resistance measured in units of ohms
- h. Ohm's law, Kirchhoff's current law, and Kirchhoff's voltage law
- i. Motor efficiency
- j. Sizing resistors for electrical circuits
- k. Series and parallel circuit operation
- l. Open or short circuit symptoms
- m. Effects caused by inductance and capacitance
- n. Phase displacement between AC voltage and current in inductive or capacitive circuit
- o. True power (W), apparent power (VA), reactive power (VAR), and power factor (%)
- p. Voltage and current calculations for either a wye or delta system
- q. Phase matching (phasing) of three-phase circuits

### **2. Electronics - 8 questions**

- a. The properties and operating principle of a diode
- b. Operational tests for a diode
- c. Half and full wave rectification circuit connections and operation
- d. Diode ratings and replacement values
- e. Rectifier filter construction and operation
- f. Soldering
- g. Basic logic gates symbols and operation, including the exclusive OR gate

### **3. Power and Current Transformers - 9 questions**

- a. Transformer theory and operation
- b. Transformer operating losses (hysteresis, eddy currents, and copper losses)
- c. Single-line symbols for three-phase transformer banks
- d. Three-phase transformer bank power, primary current, and secondary current calculations using nameplate values

- e. Transformer primary and secondary connections (internal and external)
- f. Transformer polarity and insulation tests
- g. Current transformer (CT) theory and operation
- h. Multi-ratio (tapped) CT's
- i. Safety precautions working with CT's
- j. Wye system operation with connected meters and relays
- k. CT ratings and classifications
- l. CT burden
- m. Polarity markings

**4. Electrical Drawings - 4 questions**

- a. Clapper or plunger relays with associated contacts
- b. Schematic diagram interpretation

## Attachment 1

### Sample Questions

1. In the spaces provided, write the following conversions:

a.  $10,050 \Omega =$  \_\_\_\_\_  $k\Omega$

b.  $12.47 kV =$  \_\_\_\_\_  $V$

c.  $0.123 A =$  \_\_\_\_\_  $mA$

d.  $10.6 Mw =$  \_\_\_\_\_  $w$

2. Circle the correct statement that describes what happens to a circuit with 3 resistors connected in parallel when one of the resistors is open-circuited.

- a. The circuit resistance increases.
- b. The circuit current increases.
- c. The voltage across each of the two remaining resistors increases.
- d. The amount of power consumed in the circuit remains the same.

3. Circle the correct statement that describes the operation of diodes.

- a. Diodes allow current to flow when the anode is negative in relation to the cathode.
- b. Diodes allow current to flow when the anode is positive in relation to the cathode.
- c. Diodes are only used in dc systems.
- d. Never use a diode to rectify ac.

4. Calculate the turns-ratio for a power transformer with a nameplate voltage rating of 34.655 kV to 11.95 kV. Write your answer in the space provided.

Turns-ratio = \_\_\_\_\_:1

---

*Continued on next page*

**Sample Questions, continued**

5. Shown below is a current transformer with the number of turns between taps. In the space provided, write the calculated voltage for taps X1 to X3 when 200 V is applied to the full secondary winding (X1 to X5).

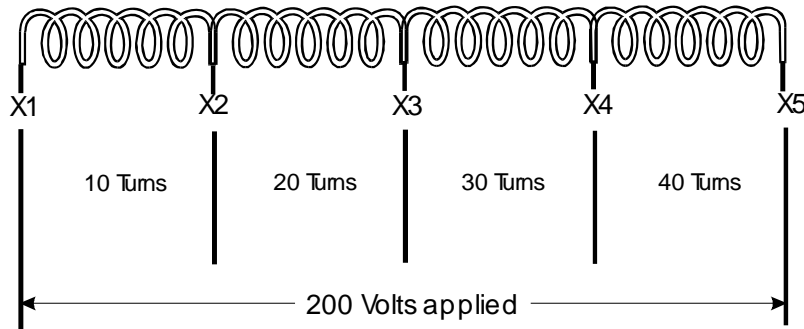

X1 to X3 = \_\_\_\_\_ Volts

6. Analyze the circuit below. Assume that all switches are open initially and then Sw. #1 is closed. Circle the correct statement.
- Lamp # 1 only is on.
  - Lamp #2 only is on.
  - Lamps #1, #2 and #3 are on.
  - Lamps #2 and #3 are on.
  - Lamp #1 and #3 are on.

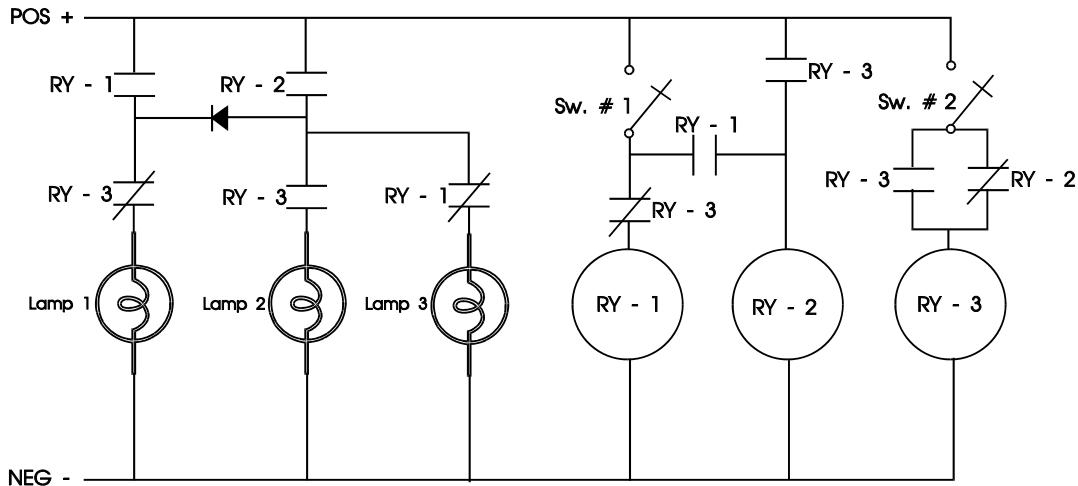

*Continued on next page*

### **Sample Questions, continued**

7. During a saturation test of a 1500/5 multi-ratio CT, 400 volts is applied to the X1 to X4 tap. The X1 to X4 tap is the 1200/5 ratio. What is the expected voltage across the X1 to X5 tap? Circle the correct answer below.
- a. 500 V
  - b. 400 V
  - c. 320 V
  - d. 240 V maximum
  - e. 0 V
8. A phase-to-phase secondary ratio test is being conducted on a wye connected set of current transformers. Test current is applied through both the A and B-phase secondary leads. Circle the statement below where the secondary ratio current is read.
- a. A-phase ammeter, A-phase relay, and the Ground relay.
  - b. A and B-phase ammeters, A and B-phase relays, and the Ground relay.
  - c. A and B-phase ammeters and A and B-phase relays.
  - d. B-phase ammeter, B-phase relay, and the Ground relay.
  - e. C-phase ammeter, C-phase relay, and the Ground relay.
9. Write in the space provided the calculated power consumed in a dc circuit that has a current of 154 amperes and a circuit resistance of 25 ohms.

Power = \_\_\_\_\_ W

10. Circle the correct statement from the list below for an ac circuit containing resistance, and capacitive reactance,
- a. The voltage and current are in-phase.
  - b. The current leads the voltage.
  - c. The voltage leads the current.
  - d. The phase angle between the voltage and current is 90°.

**Answers to sample questions listed on the following page.**

## **Sample Questions Answers**

1. a. 10.05 k $\Omega$ , b. 12,470 V, c. 123 mA, d. 10, 600,0000 w
2. a. The circuit resistance increases.
3. b. Diodes allow current to flow when the anode is positive in relation to the cathode.
4. Turns-ratio = 2.9:1
5. X1 to X3 = 60 Volts
6. a. Lamp # 1 only is on
7. a. 500 V
8. c. A and B-phase ammeters, A and B-phase relays.
9. 592.9 kW
10. b. The current leads the voltage