	OVERHEAD AND UNDERGROUND PANEL BOARD CONSTRUCTION		065374
	Asset Type: Electric Metering Issued by: Daniel Jantz (DWJ7)		Function: Design Date: 6/30/2023
Rev. #16: This document replaces PG&E Document 065374, Rev. #15. For a description of the changes, see Page 9.			

This document also is included in the following manuals:

- [Electric and Gas Service Requirements Manual \(Greenbook\)](#)
- [Electric Meter Work Practices \(EMWP\)](#)

References	Location	Document
Requirements for Customer-Owned Poles	OH: Services/Greenbook	025055
Location, Clearances, and Mechanical Protection		
Details for Pad-Mounted and Subsurface Equipment	UG-1: General/Greenbook	051122
Voltage Stabilizer for 480 Volt, Three-Phase, 3-Wire		
Ungrounded Service	OH: Meters/EMWP	052497
Agricultural Underground Service, 500 hp or Less	UG-1: Services/Greenbook	054619
Agricultural Overhead Service, 300 hp or Less	OH: Services/Greenbook	058087

Purpose and Scope

This document illustrates the requirements applicable to residential, commercial, and agricultural overhead or underground service installations served from PG&E's lines. This document is applicable where panel-type structures are used to mount customer-owned and installed equipment.

General Information

1. Construction Materials and Requirements

Ensure that all posts and panels on which the service and metering equipment are mounted meet the following minimum requirements. Equipment can be mounted to a panel, boards, or struts. See Note 5 on Page 3 for the maximum rating of service termination equipment.

A. Material Treatment and Specifications

- (1) Ensure that the surface areas on all wood posts, boards, and solid panels are pressure treated, including the sides and areas that have been cut. Any other treating process that provides an equivalent penetration and retention must be approved by PG&E. Acceptable wood preservatives are water-borne salts and pentachlorophenol. Brush application of wood preservatives is ineffective and therefore unacceptable.
- (2) Pipe posts must be galvanized rigid steel.
- (3) All metal boards or solid metal panels must be rigid steel and have a rust inhibitor applied to all surface areas.
- (4) Strut channels, fittings, and associated hardware must be stainless steel or galvanized steel.

General Information (continued)

B. Material Dimensions

- (1) Structure: All structures must be a minimum length of 48 inches. For structures up to 72 inches long, the minimum combined height of the boards, panel, or struts must be 36 inches. For structures up to 96 inches long, the minimum combined height of the boards, panel, or struts must be 42 inches. For structures with lengths greater than 96 inches, use additional posts. The top of the structure must not exceed 84 inches high from the ground. There must be a minimum of 6 inches of clearance between the ground and all equipment, panels, boards, or struts.
- (2) Boards: Place side by side.
 - (a) Wood: Minimum 2 inches thick by 12 inches wide (nominal).
 - (b) Metal: Minimum 1/2 inch thick by 12 inches wide.
- (3) Panel: One solid sheet.
 - (a) Wood: 1 inch thick.
 - (b) Metal: 1/4 inch thick.
- (4) Unistrut: At a minimum, two struts are needed to support each piece of service and metering equipment. It is recommended that one strut be attached towards the top and one strut be attached towards the bottom of the equipment. Add struts for additional equipment with different length dimensions. Use struts with or without boards or panels.
 - (a) Strut channel dimensions must be a minimum 1-1/2 inch x 1-1/2 inch. See Figure 10 on Page 8.
- (5) Posts: Use a minimum of two posts to support panel-type construction. Add more posts if the construction exceeds the structural dimensions listed in Note 1B(1) on Page 1. If applicable, a PG&E-approved, customer-owned pole can be used as one of the posts. The customer-owned pole must be installed in accordance with [Document 025055](#) and the panel board must be attached to the poles as shown in Figures 8 on Page 5 and Figure 10 on Page 8.
 - (a) Wood: Solid.
 - (i) Square, 6 inches by 6 inches cross section.
 - (ii) Round, 8 inches in diameter.
 - (b) Metal: Solid or hollow. If hollow a permanent post cap is required.
 - (i) Square, 3 inches by 3 inches cross section.
 - (ii) Round, 3 inches in diameter.

C. Footing and Support

- (1) Place all posts in the center of a 12 inches minimum diameter concrete footing. Extend the footing a minimum of 36 inches into the ground (excluding gravel bedding), a minimum of 4 inches above ground level, and have a 1/2 inch slope away from the post to allow for drainage.

D. Fasteners

- (1) For wood posts, use minimum 3/8 inch x 5 inches lag screws.
- (2) For metal posts, use 3/8 inch minimum through bolts with nuts and washers.
- (3) For Unistrut, use approved fasteners and hardware made for the strut channels. This should include through bolts with nuts and washers.

E. Screw Holes or Openings

- (1) All unused or exposed screw holes and openings must be tightly secured by plugging or filling the entire hole with screws, bolts, or other type of metal fasteners. Sealants can be used along with the screws, bolts, and other metal fasteners.

F. Clearances and Barrier Posts (see [Document 051122](#))

- (1) A minimum 36 inches of clear and level working space must be maintained in front of the panel board structure at all times.

Overhead and Underground Panel Board Construction

- (2) If any part of the panel board structure is located within 36 inches of a thoroughfare or road, then install barrier posts. If the thoroughfare or road has high vehicular traffic and the panel board structure is less than 108 inches (9 feet) away, then install barrier posts.
- (3) The panel board and customer owned pole (if installed) must not be located less than 10 feet from the surface of the PG&E pole or within 10 feet of the vertical plane of a PG&E line.

2. Grounding

The customer is responsible for bonding and grounding metering and service termination equipment enclosures. See the requirements in Greenbook Section 5.8. Grounding, including Figures 5–15 and 5–16. Also Ground and bond in accordance with the National Electrical Code (NEC) and local ordinances. PG&E prefers, but does not require, the grounding electrode conductor wire to be protected against physical damage by rigid steel conduit or armored cladding

3. A voltage stabilizer for 3-wire service will be furnished and installed by PG&E (see [Document 052497](#)).
4. Properly identify and mark meters as described in Section 5.5.1 on Page 5-10 of the [Electric and Gas Service Requirements Manual \(Greenbook\)](#).
5. Termination or metering equipment with an ampacity rating greater than 400 amps, 1-phase or 3-phase must be pad-mounted (free standing). Refer to [Electric and Gas Service Requirements Manual \(Greenbook\)](#), Section 9.10.
6. The minimum meter height for electric panels with current transformers (CT's) is 60 inches as measured from final grade to the center of the meter. The maximum meter height is 75 inches.
7. Enclosure: For services greater than 100 feet install a pull box between 30 feet maximum and six feet minimum away from the Panelboard. See document [028028](#) Secondary Electric Underground Enclosures for the required minimum size enclosure to install.

Typical Panel Board Construction

Notes

1. See Table 1 on Page 8 for the material list.
2. Item 2 may be replaced by Items 1 and 3.

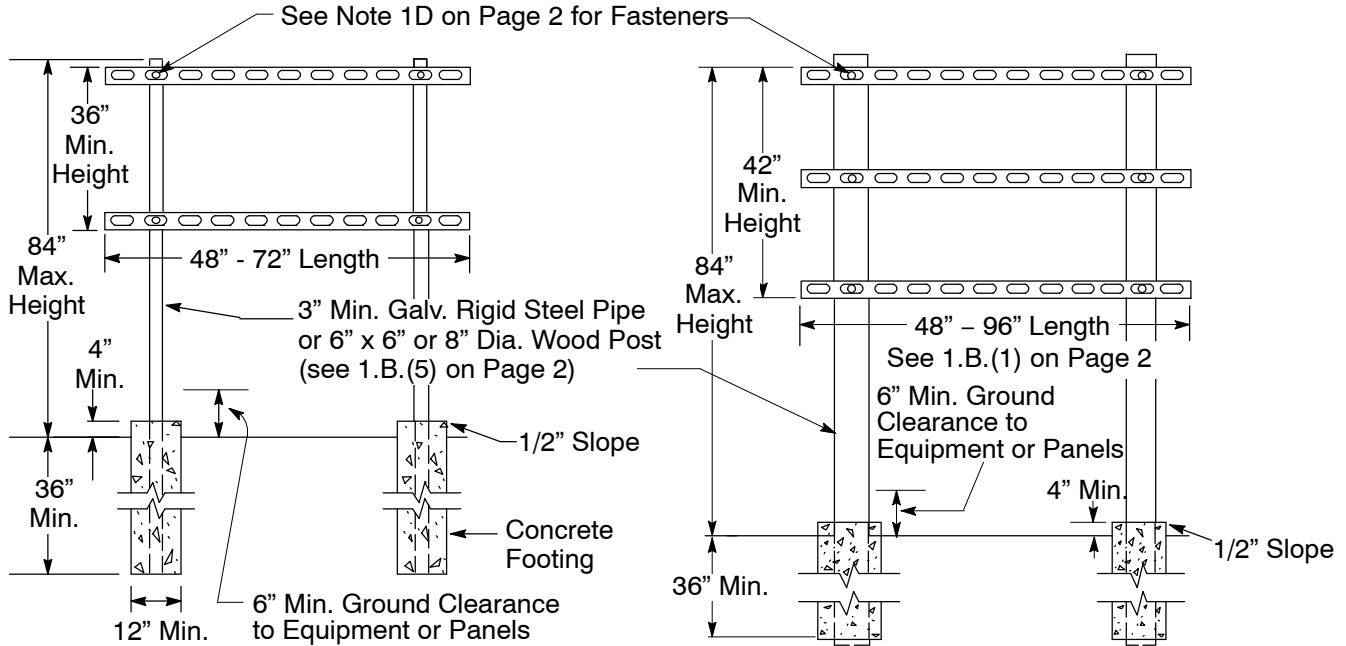

Figure 1
Panel Board Construction With Struts

Figure 2
Large Panel Board Construction With Struts

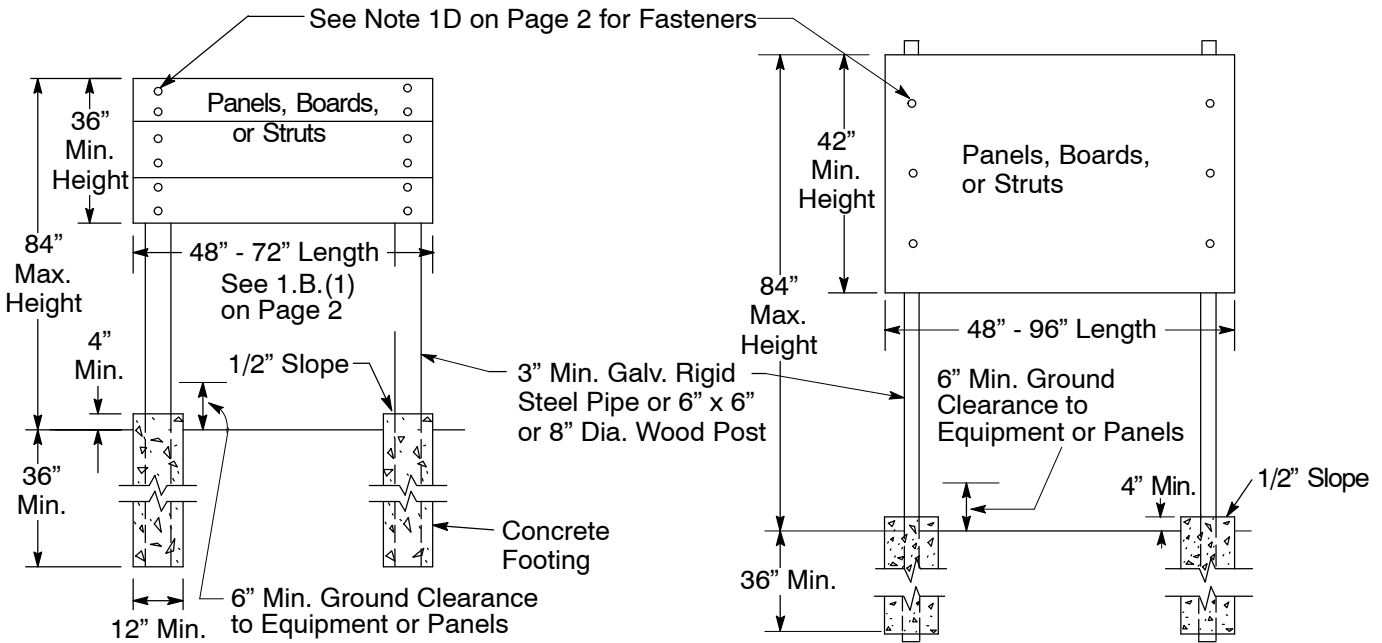
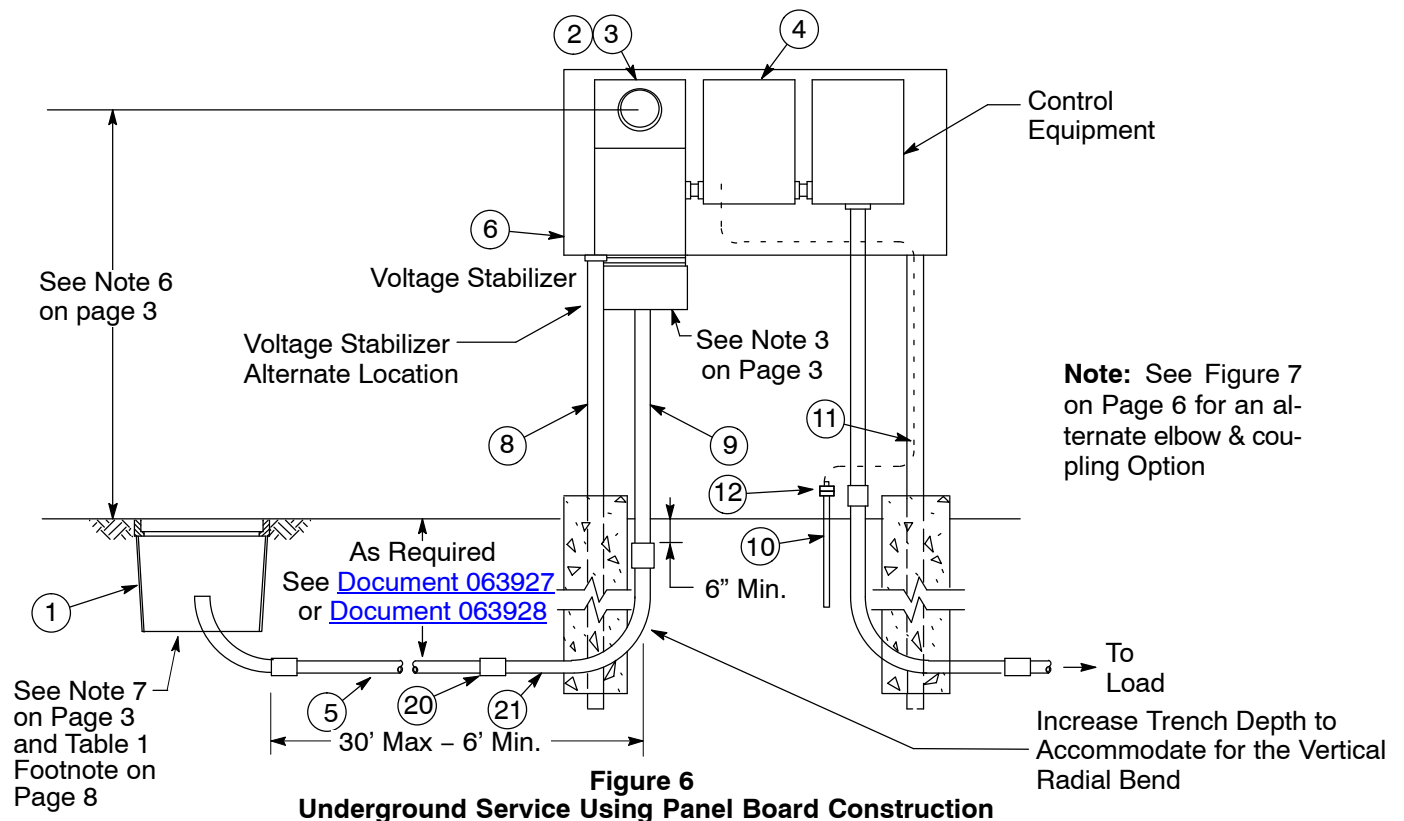
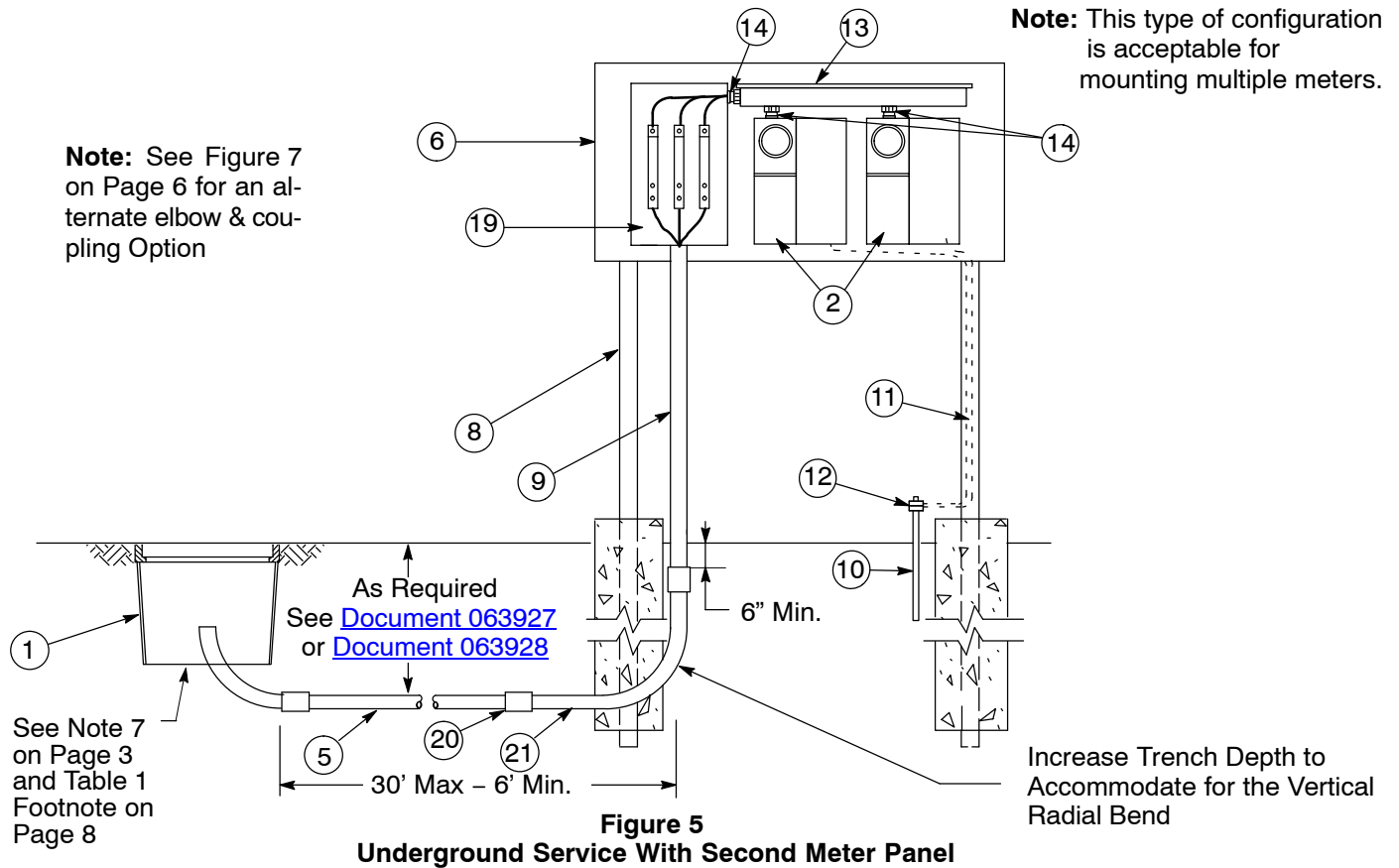

Figure 3
Panel Board Construction

Figure 4
Large Panel Board Construction

Typical Underground Panel Board Construction



Overhead and Underground Panel Board Construction

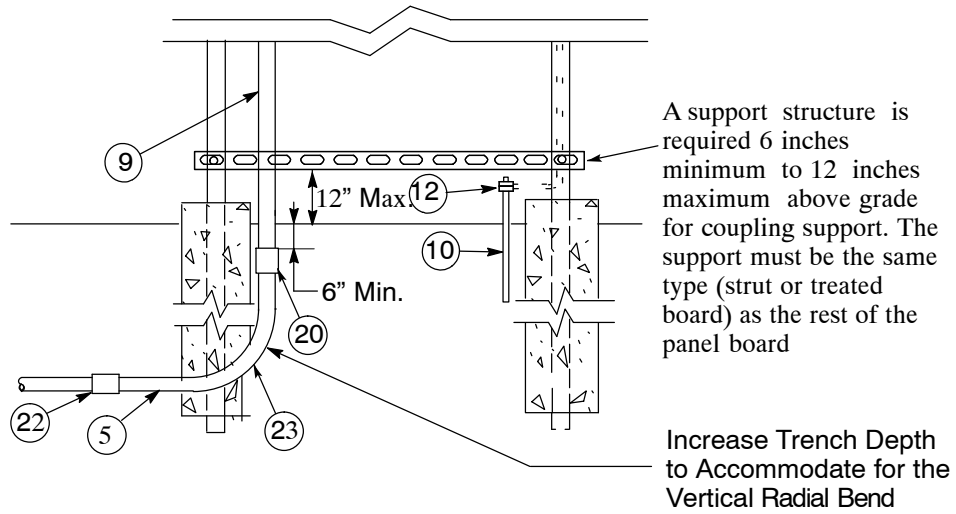
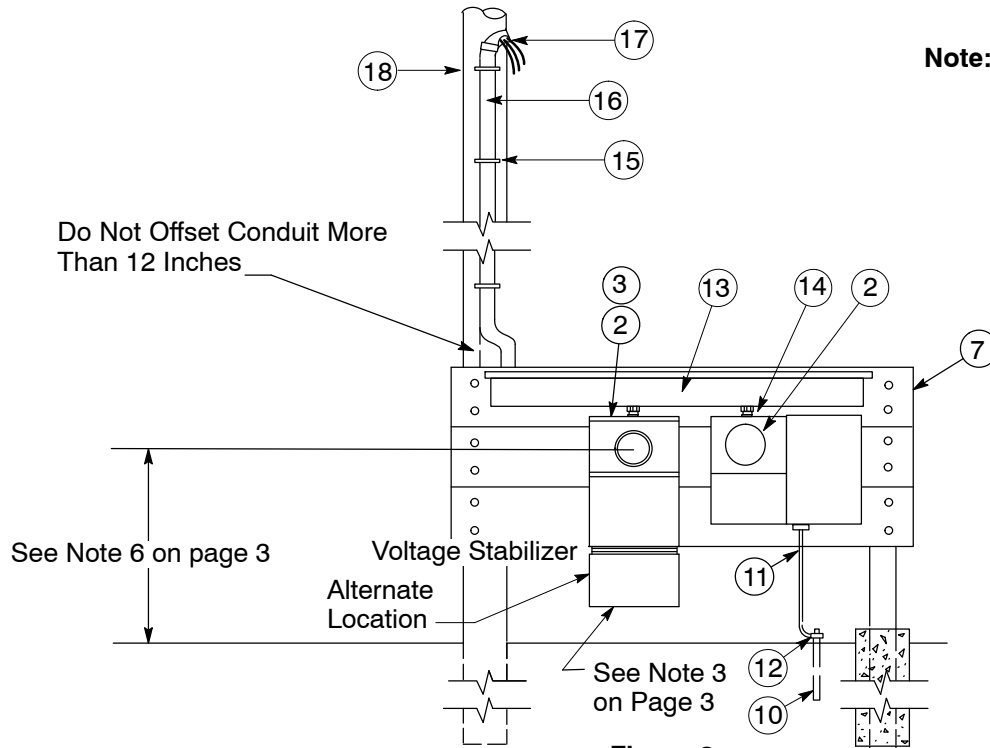

Figure 7
Alternate Option - PVC Elbow (Item 23) & Plastic-to-Steel Adapter / Coupling (Item 20)

Overhead and Underground Panel Board Construction

Typical Overhead Panel Board Construction



Note: This type of configuration is acceptable for mounting multiple meters.

Figure 8
Overhead Service With Second Meter Panel

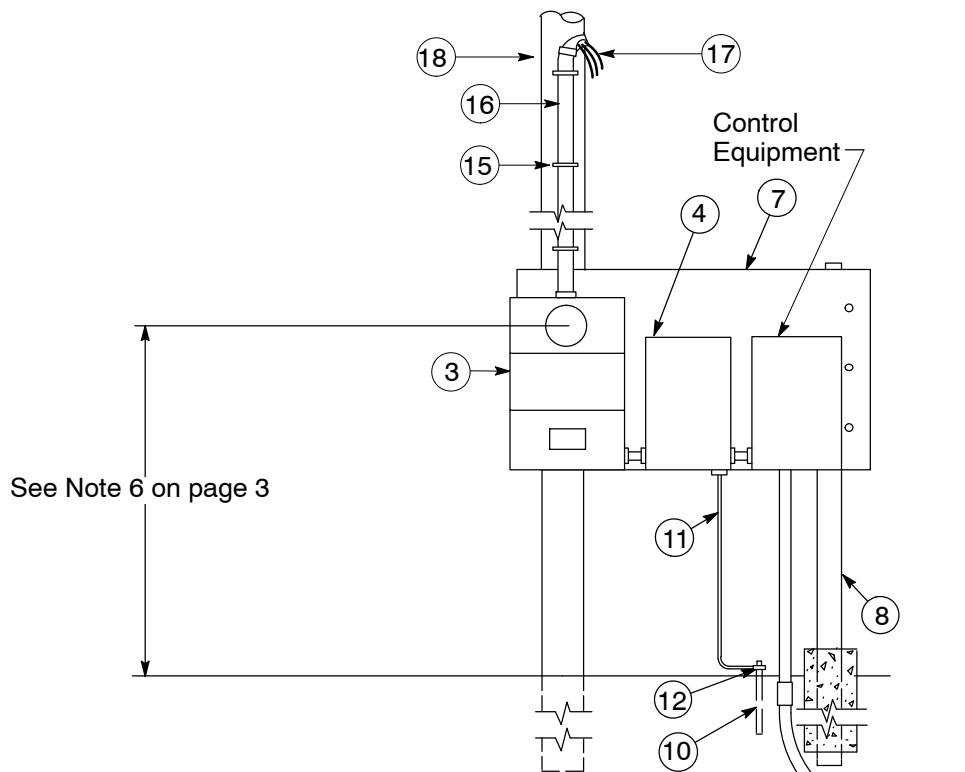

Figure 9
Overhead Service Using Panel Board Construction

Overhead and Underground Panel Board Construction

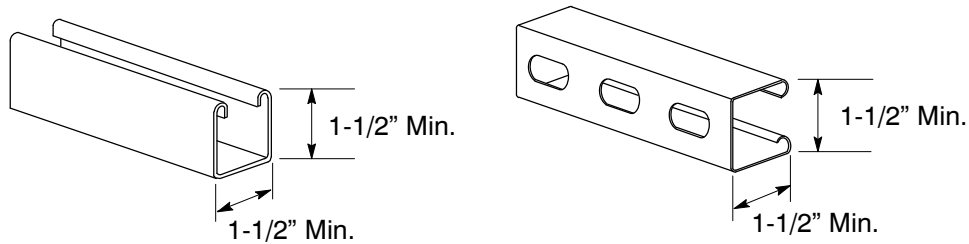

Figure 10
Typical Strut Channels Used for Panel Board Construction

Table 1 List of Material To Be Furnished and Installed by Customer

Item	Description
1	Underground Pull Box, Required ¹
2	Self-Contained, Bused Safety Socket Box
3	Combination Meter and Current Transformer Cabinet (See Note 6 on Page 3)
4	Main Switch of Service Equipment Enclosure
5	Service Conduit, As Required
6	UG Panel Board Construction (See Figures 5 – 6)
7	OH Panel Board Construction (See Figures 7 – 8)
8	Post (See Note 1 on Page 1)
9	Conduit, Riser, Galvanized Rigid Steel, Continuous without Couplings
10	Ground Rod (See Note 2 on Page 3)
11	Ground Wire, Copper, Bare
12	Ground Clamp (As Required) for Item 10
13	Sealable Gutter
14	Metal Myers Hub With Close Nipple
15	Heavy Duty 2-Hole Pipe Strap Every 36"
16	PVC Schedule 40, minimum
17	Weatherhead
18	PG&E-Approved, Customer-Owned Pole
19	Termination Enclosure
20	Plastic-to-Steel Adapter/Coupling
21	Conduit, Bend, Galvanized Rigid Steel, Continuous without Couplings
22	Service Conduit, Coupling, As Required
23	Conduit, Bend, PVC, Continuous without Couplings

¹ The pull box is required to be installed but may be exempt only at the discretion of the PG&E inspector.

Revision Notes

Revision 16 has the following changes:

1. Revised Note 5 on Page 3.