



AGRICULTURAL OVERHEAD SERVICE 300 HP OR LESS

058087

Asset Type: Electric Metering **Function:** Design and construction
Issued by: Lisseth Villareal (LDV2) *Lisseth Villareal* **Date:** 12/01/19

Rev. #15: This document replaces PG&E Document 058087, Rev. #14. For a description of the changes, see Page 12.

This document is also included in the following manual:

- [Electric and Gas Service Requirements](#) (Greenbook)
- [Electric Meter Work Practices](#)

Purpose and Scope

This document establishes and illustrates the required methods of providing overhead agricultural service of 300 horsepower (hp) or less.

General Information

1. This document applies to agricultural loads rated 5 through 300 hp, provided both of the following conditions are met.
 - A. The service is overhead.
 - B. The load current does not exceed the ampere limitation of the service entrance equipment or PG&E facilities.
2. Service Request: The customer should make application for service and verify the available service voltage with PG&E as far in advance of construction as possible. The customer should then notify his pump company of the available PG&E service voltage.
3. Available Service Voltage:
 - A. Non-residential single-phase loads to a maximum of 7-1/2 hp shall be served at 120/240 V, single-phase, 3-wire.
 - B. Three-phase motors of 5 hp, or bigger up to 30 hp, will normally be served at 120/240 V, three-phase, 4-wire, but may be served at 120/208 V or 277/480 V at the customer's option and if capacity is available from existing facilities.
 - C. Single or grouped three-phase motors of 30 hp up to 50 hp can be served from an open-delta transformer producing service voltage at 120/240 V, three-phase, 4-wire, if the customer has a combination of single and three-phase loads, otherwise they must be served at 120/208 or 277/480 V, three-phase, 4-wire.
 - D. Single or grouped three-phase motors from 60 hp through 125 hp shall be served at 120/208 V or 277/480 V, three-phase, 4-wire.
 - E. Single or grouped motors of 150 hp through 300 hp shall be served at 277/480 V, three-phase, 4-wire.
4. General Requirements: PG&E shall furnish and install the overhead service drop, meters and metering current transformers. Unless otherwise stated, all other materials shall be furnished, installed and maintained by the customer and shall comply with the requirements of PG&E. It shall be the responsibility of the customer to ascertain and comply with the requirements of governmental authorities having jurisdiction. In areas where no provision is made for inspection by local authorities, the applicable state regulations shall apply. Local ordinances may include wiring requirements in addition to those shown in this document or in the National Electrical Code (NEC). Consult inspection authorities for requirements, city or county permits, and inspections that may be required before service can be connected.
5. Clearances: All overhead conductors may not be in a vertical plane **any** closer than 10 feet from any wellhead. The vertical plane is the plane created between the overhead conductors and the ground. Refer to Figure 1 on Document [025055](#).

6. Service Pole: When a service pole is required, it shall have a minimum length of 25 feet (set 4-1/2 feet in the ground) unless a longer pole is needed for required ground clearance or to accommodate additional PG&E equipment. The pole will be located at least 10 feet from the motor or load and in such a position that the overhead conductors and any required guy will not interfere with work done at the motor or load. A PG&E pole with high-voltage conductors (over 600 V) shall not be used as a service pole. Refer to [Document 025055](#) for further information on the requirements for customer-owned poles.
7. Service Entrance Conductor:
 - A. The conductors shall be sized and installed in accordance with the applicable requirements of the NEC.
 - B. A minimum of 18 inches of conductor shall be provided outside of the service head to make connection with PG&E's service drop.
 - C. When the meter enclosures shown in Figure 9 through Figure 11 on Page 10 are used, the customer shall furnish and connect all line and load-side service entrance conductors.
 - D. When metering equipment requiring a current transformer (Figure 12 on Page 11 through Figure 15 on Page 11) is used, the customer shall furnish lugs and connect conductors to the line and load sides of the current-transformer mounting base. The unmetered conductor may be cable, but shall be continuous and unspliced in the current-transformer cabinet and shall be located so as to not interfere with the current-transformer installation.
8. Service Entrance Conductor Covering for Service Poles:
 - A. All wires between the service head and the meter shall be enclosed in any of the following:
 - (1) galvanized rigid steel conduit
 - (2) rigid aluminum conduit
 - (3) electrical metallic tubing
 - (4) intermediate metallic conduit
 - (5) PVC plastic conduit having a minimum wall thickness of 0.15 inches (Schedule 40 for 2" PVC conduit or larger, Schedule 80 for 1-1/2" PVC conduit or smaller)All fittings shall be raintight.
 - B. If PVC plastic conduit is used, it need not be covered. If rigid steel or other approved metallic conduit is used, it shall be enclosed with either 1/4-inch thick fiber conduit, 1-1/2-inch thick wood covering or PVC "U" shaped moulding for a minimum distance of 8 feet below the lowest open service entrance conductor. The covering shall be strapped to the pole at intervals not greater than 3 feet (see Pages 7 and 8).
9. Grounding: The customer shall be responsible for bonding and grounding all exposed, non-current-carrying metal parts. Bonding and grounding shall be in accordance with the NEC and local ordinances. PG&E prefers, but does not require, the grounding electrode conductor wire to be protected against physical damage by rigid steel conduit or armored cladding.
10. Metering Requirements:
 - A. The arrangement of service equipment shall place the meter and current-transformer cabinet (if required) on the source side of the customer's service switch or breaker.
 - B. 125 hp or less: The customer shall provide and install a self-contained, meter socket enclosure, approved by PG&E, for the available service voltage, in accordance with Table 1 on Page 5 and Figure 9 through Figure 11 on Page 10.
 - C. 130 hp through 300 hp: The customer shall provide and install a PG&E-approved combination meter and current-transformer cabinet in accordance with Table 1 on Page 5 and as shown in Figure 12 and Figure 13 on Page 11, or, as an option, the current-transformer cabinet and separate transformer-rated meter safety-socket box as shown in Figure 14 and Figure 15 on Page 11.
 - D. Non-residential (agricultural) customer-owned poles are limited to only one meter panel rated less than or equal to 200 amps. Two or more meter panels or a meter panel rated greater than 200 amps must be installed on a panel board construction as shown in [Document 065374](#).

11. Customer's Control Equipment:

- A. Customer's switch and motor control equipment shall be of proper horsepower and voltage rating and, when exposed to weather, shall be weatherproof.
- B. The customer's control equipment shall be selected in accordance with the requirements of NEC Article 430 and local ordinances. Consideration should also be given to installing open-phase and reverse-phase protection.
- C. Customer's switch and motor control cover shall be effectively locked or sealed if the enclosure contains accessible electrically energized parts.
- D. When a service pole without an adjacent panel board is used, the customer's switch and motor control equipment may be installed as shown on Pages 7 and 8. One side of the pole must be kept clear for climbing.

12. Services to Three-Phase Pumps:

- A. When three-phase service is established to a pump, PG&E's crew will assist in checking for satisfactory pump motor performance if the customer or his representative is present. The construction crew should take "Clamp-on" ammeter readings at the service head, or the customer or his representative can take them at the motor control box. If the reading on the "high" phase is more than 10% higher the reading on the "low" phase, then the phases should be rolled to get the readings as close as possible (see Figure 1 below). The set of readings that gives the lowest difference is the connection that should be retained. It is possible that none of the other readings will be any better. Use the "[Motor Data Sheet](#)", to record all readings.
 - (1) Starting and stopping of the pump should be done only by the customer or his representative. Connections can be changed at the transformer pole or service pole by PG&E's crew or at the motor control box by the customer or his representative.
 - (2) On 240 V, 3-wire services where one phase conductor is grounded, all rolling of leads must be done on the customer's motor leads (at the motor control box), not on PG&E's service leads.
 - (3) Example

Once water was flowing satisfactorily from the pump, the following ammeter readings were taken:

<u>Connection</u>	<u>Amperes</u>		
	<u>L1</u>	<u>L2</u>	<u>L3</u>
A = Original Readings	60	61	67
B = Second Set of Readings	60	62	63
C = Third Set of Readings	59	62	66

Conclusion: Connection B should be used.

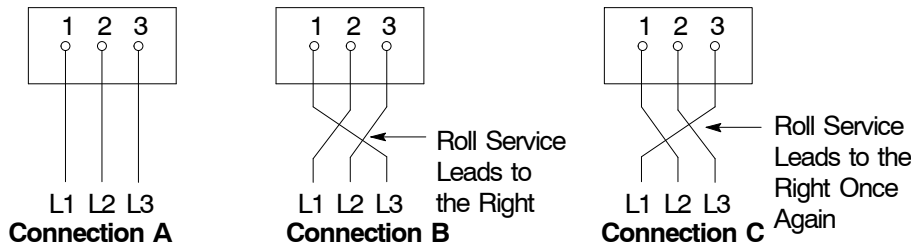

**Figure 1
Rolling Leads
(maintains same rotation)**

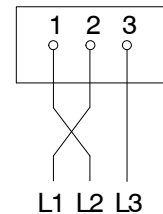

**Figure 2
Interchanging Leads
Reverses Rotation
(for information only)**

- 13. Voltage stabilizer will be furnished and installed by PG&E. Voltage stabilizer is required on 480V, 3-phase, 3-wire ungrounded installations. Refer to [Document 052497](#).

References	Location	Document
Dead-End Attachments for Service and Streetlight		
Drop Cables	ELS	015009
Spool and Clevis-Type Insulators–Distribution Lines ..	OH: Conductors	022439
Requirements for Customer-Owned Poles	OH: Services/Greenbook	025055
Dead-End and Angle Attachments for Aluminum		
Conductors - Distribution Lines	OH: Conductors	028851
Voltage Stabilizer for 480 Volt, Three-Phase, 3-Wire		
Ungrounded Service	OH: Meters/EMWP	052497
Agricultural Underground Service 500 HP or Less	UG-1: Services/Greenbook	054619
Cable and Accessories for Secondary Aerial Cable		
Construction	OH: Framing	057876
Miscellaneous Hardware for Overhead Line		
Construction	OH: Framing	058778
Conductors for Overhead Lines	OH: Conductors	059626
Underground Conduits	UG-1: Conduits	062288
Overhead and Underground Panel Board		
Construction	OH-Services/UG-1: Services	065374
Fired Wedge Connectors for Primary and Secondary		
Distribution Lines	OH: Conductors	066194

Agricultural Overhead Service 300 HP or Less

Table 1 Customer's Metering Equipment Requirements ¹

Service Voltage ²	Maximum hp ³ Single or Grouped Motors	Metering Equipment's Minimum Current Rating (Continuous/Max. Amps Shown) ⁸	Type Meter Equipment Required	Refer to	
120/240 V Single-Phase, Non-Residential, 3-Wire	7-1/2 hp Single Phase	100	Self-Contained 4-Jaw Bussed Safety-Socket Meter Box	Figure 9 Page 10	
240 V Delta Three-Phase, 3-Wire ⁴	30 hp Single or Grouped	100	Self-Contained 5-Jaw Bussed Safety-Socket Meter Box	Figure 10 Page 10	
	60 hp Single or Grouped	200			
240/120 V Delta Three-Phase, 4-Wire ⁵	30 hp Single or Grouped	100	Self-Contained 7-Jaw Bused Safety-Socket Meter Box	Figure 11 Page 10	
	50 hp Single or Grouped	200			
480 V Delta Three-Phase, 3-Wire ⁶	60 hp Single or Grouped	100	Self-Contained 5-Jaw Bussed Safety-Socket Meter Box	Figure 10 Page 10	
	125 hp Single or Grouped	200			
	300 hp Single or Grouped	400 ⁷	Combination Meter, Current-Transformer and Service Termination Cabinet With 8-Jaw Socket and CT Mounting Base		Figure 12 Page 11
			Separate Current-Transformer Cabinet and Transformer-Rated Meter Box		Figure 14 and Figure 15 Page 11
277/480 V Wye Three-Phase, 4-Wire	60 hp Single or Grouped	100	Self-Contained 7-Jaw Bussed Safety-Socket Meter Box	Figure 11 Page 10	
	125 hp Single or Grouped	200			
	300 hp Single or Grouped	400 ⁷	Combination Meter, Current-Transformer and Service Termination Cabinet With 13-Jaw Socket and CT Mounting Base		Figure 13 Page 11
			Separate Current-Transformer Cabinet and Transformer-Rated Meter Box		Figure 14 and Figure 15 Page 11

¹ For meter equipment illustration, see Pages 10 through 11.

² See Note 3 on Page 1 for available service voltages.

³ Maximum horsepower for single and grouped motors is based on nameplate rating. Ratings shown are the recommended values for motors running at full load.

⁴ Limited availability, consult PG&E.

⁵ See Note 3.C on Page 1.

⁶ 480 V Delta is not available for new services.

⁷ Customer metering equipment rated higher than 400 amps, three-phase, must be pad-mounted and supplied by an underground service.

⁸ The metering equipment ratings shown must not be exceeded with motors running at full load. Customer may choose metering equipment with a greater ampacity rating.

Pole Construction

Notes: (For additional information on the requirements for customer-owned poles refer to [Document 025055](#))

1. Omit wood block (see Table 3, Item 1 on Page 7) and conduit covering (see Table 3, Item 5 on Page 7) when PVC service conduit is used. Exception: Wood block is required when service weatherhead is metallic and the neutral service entrance conductor is uninsulated.
2. When the service conduit (see Table 3, Item 6 on Page 7), is metallic or minimum 2-1/2 inch diameter PVC Schedule 80, the enclosure height may be reduced as permitted by [G.O. 95](#) to allow 48 inches minimum meter height from a level standing surface to the center line of the meter.
3. The customer shall extend the service weatherhead to within 18 inches of the pole top unless otherwise instructed by PG&E (see Note 7A on Page 2).
4. For notes and details pertaining to metering equipment, see Note 10 on Page 2.
5. For notes and details pertaining to customer's service disconnect and motor control equipment, see Note 11 on Page 3.
6. Customer's conductors installed in conduit must be in rigid steel conduit, or 2-1/2 inch minimum diameter Schedule 80 PVC plastic on surface of pole.
7. Alternate location for the ground rod to reduce exposure to agricultural equipment is shown in Figure 3 on Page 7.

Table 2 Customer's Service Attachment Location ^{1,2}

Metering Equipment's Current Rating (Continuous/ Max. Amps Shown) ⁴	Weatherhead Distance From Top of Pole (inches)		PG&E Service Attachment Type
	Minimum	Maximum	
< = 200	16	18	Weatherhead
400 (1 Ø) ³	32	34	3 Spool Rack ⁵
400 (3 Ø) ³	40	42	4 Spool Rack ⁵

¹ All open wire services require vertical rack construction. See Figure 8, Page 8.
² A longer pole may be necessary to obtain the required service clearances from the ground. See Document [025055](#) Requirements for customer-owned poles.
³ See note 10.D on page 2.
⁴ The metering equipment ratings shown must not be exceeded with motors running at full load. Customer may choose metering equipment with a greater ampacity rating for their metering equipment.
⁵ The installation of extended rack brackets is no longer allowed. Use Vertical rack construction. See Figure 8 on Page 8.

Pole Construction (continued)

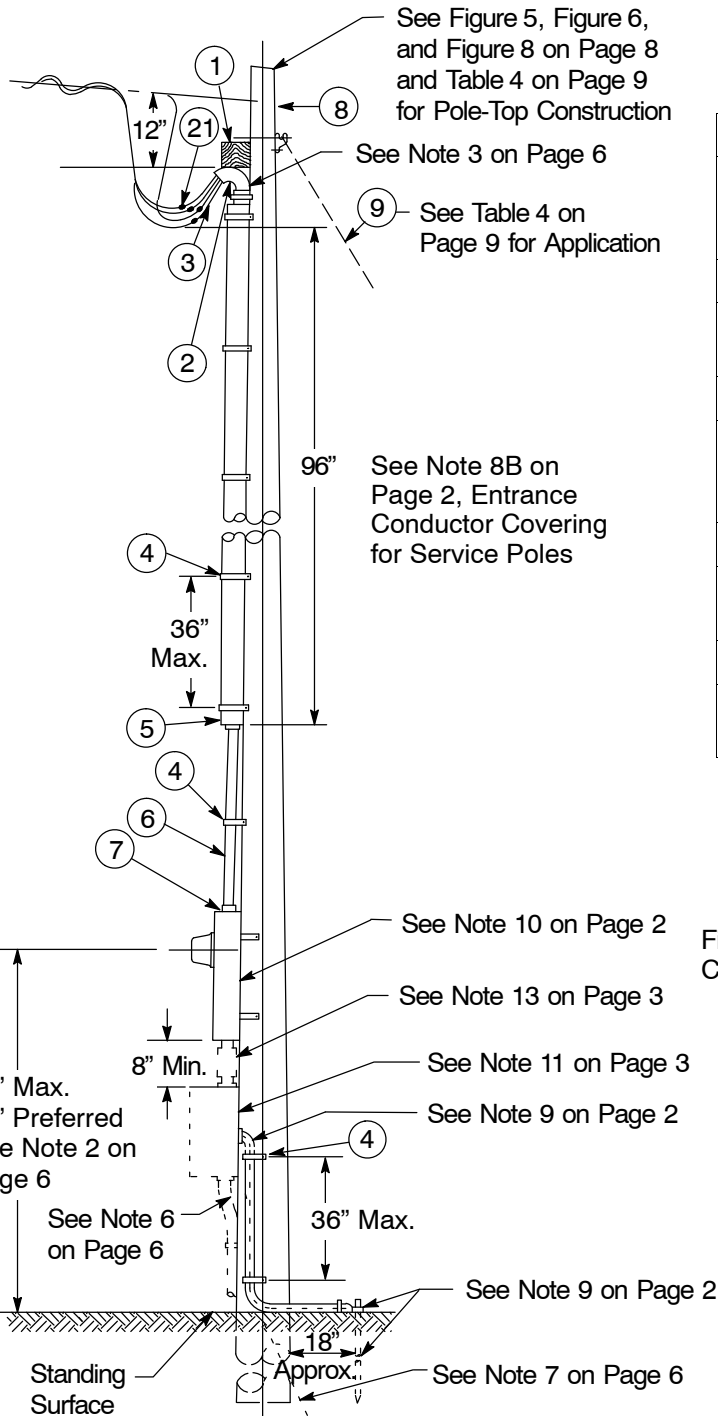

Figure 3
Pole Construction for Agricultural Overhead Service 300 hp or Less

Table 3 Material to be Furnished and Installed by Customer

Item	Description
1	Wood Block 4" x 4" x 6" Long Securely Nailed to Pole (may be two 2" x 4" x 6" wood blocks nailed together) (see Note 1 on Page 6)
2	Conduit Entrance Cap or Service Weatherhead
3	Service Entrance Conductors (see Note 7A on Page 2)
4	Pipe Strap, Heavy Duty, Galvanized
5	Covering, Wood, Fiber Conduit or PVC "U"-Shaped Moulding (see Note 8B on Page 2 and Note 1 on Page 6)
6	Service Conduit (see Note 7 on Page 2)
7	Meter Socket or Current-Transformer Enclosure (see Pages 10 through 11)
8	Wood Pole, as Required (25 ft. minimum)
9	Guy Material, as Required. (See footnotes for Table 4 on Page 9)

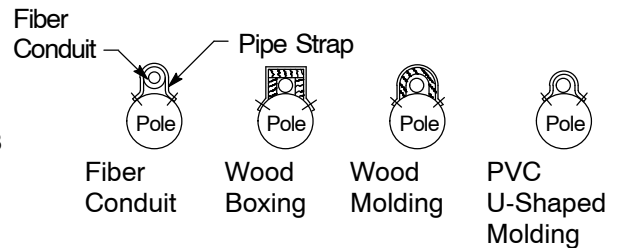

Figure 4
Methods Of Covering Metallic Conduits (see Note 8B on Page 2)

Pole-Top Construction

Notes

1. See Table 4 on Page 9 for down guy requirements.
2. When a neutral conductor is required inside the molding, replace the bare neutral with the required length of insulated conductor.
3. For customer-owned poles, span lengths are limited to 150'. The vertical separation between conductors in vertical rack construction is 8" minimum.
4. Figure 6, Page 8 installation is not allowed for new construction.

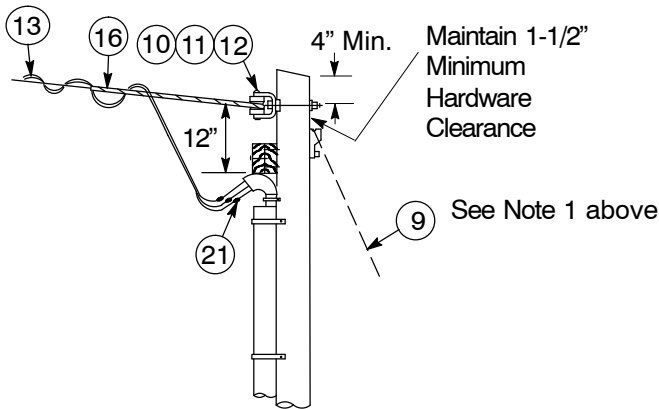

Figure 5
Service Drop Cable Installation

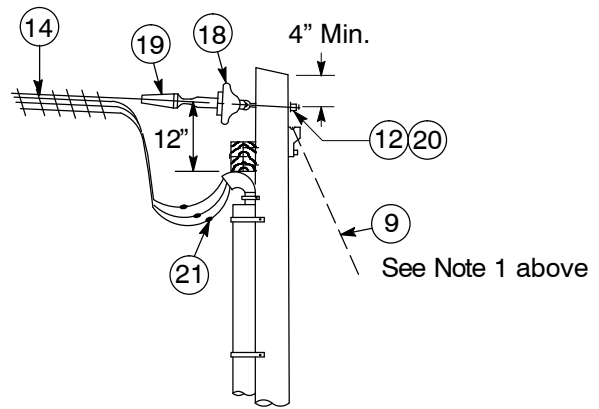

Figure 6
Aerial Cable Installation
See Note 4 above

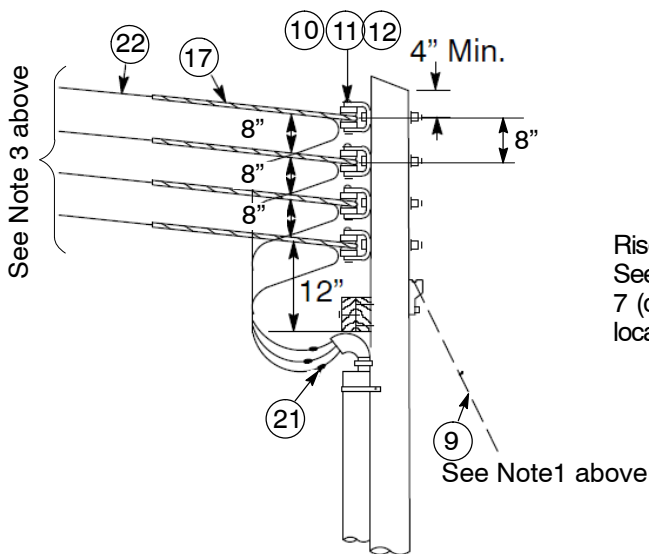

Figure 8
Open Wire Cable Installation

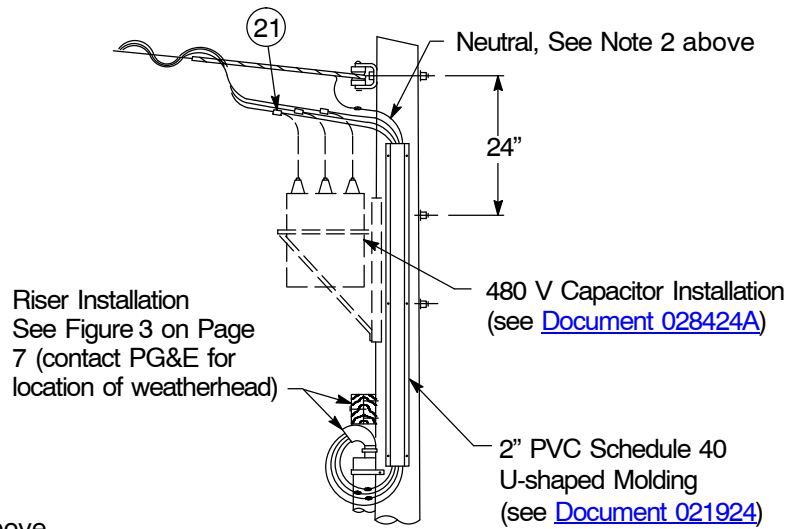

Figure 7
Pole-Top Construction for Installation of 480 V
Capacitor Bank or Other PG&E Equipment

Pole-Top Construction (continued)

Table 4 Conductor Application for Customer-Owned Service Poles

Cable Data ¹			Construction	
Metering Equipment's Current Rating (Continuous/Max. Amps shown)	Span ⁴ (feet)	Slack Span ³	Down Guy Requirement	Pole-Top Construction
≤ 200	10-150	1/0 Service Drop	2	Figure 5 Page 8
	10-80	4/0 Service Drop	2	Figure 5 Page 8
Above 200 to 400	10-80	4/0 Service Drop	2	Figure 5 Page 8
	10-80	397.5 WP Al Open Wire	2	Figure 8 Page 8

- ¹ Larger cable may be required if voltage drop requirements are not met.
- ² A down guy is required if construction crosses the street or thoroughfare, or if the pole is not in reasonably firm soil.
- ³ Full Tension Span are allowed for existing installations and like for like replacements, but not new construction.
- ⁴ Span length limitations are based on light loading districts. See Document [059690](#) for service drop limitations in other loading districts.

Table 5 Material to be Furnished and Installed by PG&E

Item	Description	Document
10	Insulator, Spool and Clevis-Type	022439
11	Bolt, Machine, 5/8" x Length (as required)	058778
12	Washer, 2-1/4", Square, 5/8" Bolt Size	
13	Cable, Service Drop, 1/0 or 4/0 (as required)	059626
14	Cable, Aerial, 1/0 or 4/0 (as required)	057876
15	Watt-Hour Meter, Current Transformer, Test Block, Test Switch (see Note 9 on Page 2)	-
16	Preformed Grip, Service Cable	028851
17	Preformed Grip, WP Aluminum	028851
18	Insulator, Suspension, Clevis-Type	057876
19	Dead End, Automatic, Clevis-Type	
20	Eyebolt, 5/8" Diameter x Length (as required)	058778
21	Connector, Fired Wedge (size as required)	066194
22	Cable, 397.5 kcmil WP Aluminum (as required)	059626

Safety-Socket Meter Box

Notes

1. Refer to PG&E's [Electric and Gas Service Requirements](#) book for dimension and specification details.
2. Figure 10 and 11 are applicable to maximum of 125 hp pump (self-contained) at 480 V or 277/480 V.
3. 240 V, three-phase, 3-wire service is limited and available only when PG&E's transformers are of the overhead type, the load is limited to three-phase motors (small 240 V, single-phase loads may be permissible in some locations), and in the future, other customers are not likely to be served from the transformer bank.
4. Figure 9 below shows a meter socket with test bypass facilities used for non-residential single-phase service, 120/240 V maximum of 7-1/2 hp. All three-phase services require bypass facilities.
5. Voltage stabilizer, required on 480 V, 3-phase, 3-wire ungrounded services, will be furnished and installed by PG&E. Refer to [Document 052497](#).

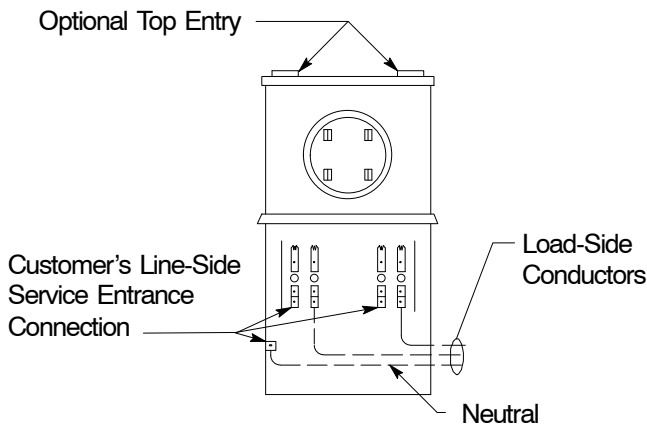

Figure 9
120/240-V, Single-Phase, Self-Contained, 4-Jaw
Based 0-200 Amp Safety-Socket Meter Box
See Note 4 above

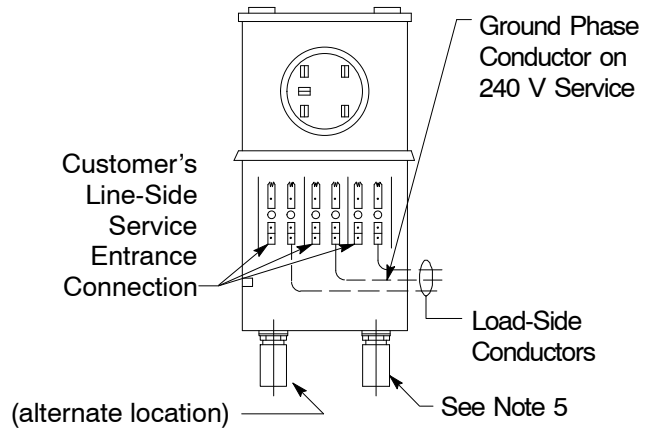

Figure 10
240-V and 480-V, Three-Phase, 3-Wire,
Self-Contained, 5-Jaw Based 0-200 Amp
Safety-Socket Meter Box
See Note 3 above and Footnote 6 on Page 5

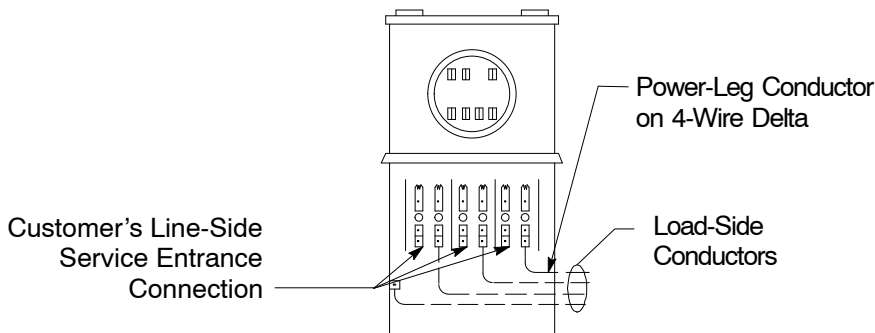

Figure 11
240/120-V, Three-Phase 4-Wire Delta or 480/277-V, Three-Phase, 4-Wire Wye
Self-Contained 7-Jaw Based 0-200 Amp Safety-Socket Meter Box
See Note 2 above

Transformer-Rated Metering and Enclosure

Notes

1. Refer to PG&E's [Electric and Gas Service Requirements](#) book for dimension and specification details.
2. Figures 12 through 15 are applicable to a maximum of 300 hp motors.
3. Figures 12 through 15 are applicable to wall-mounted service termination enclosures with maximum ratings of 400 amps, three-phase. Termination equipment that require ratings higher than 400 amps must be pad-mounted and supplied by an underground service.

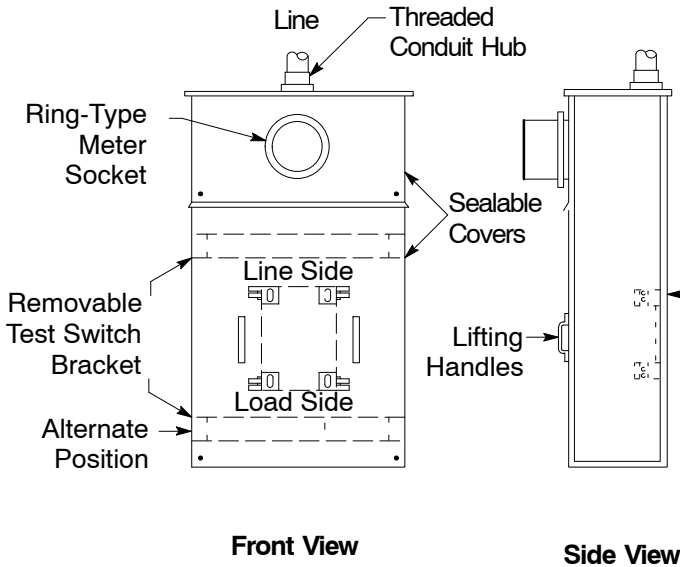

Figure 12
Combination Meter and Current-Transformer Cabinets
0-400 Amp Rating
For 480 V, 3 ϕ , 3-Wire
(See Table 1, Footnote 6 on Page 5)

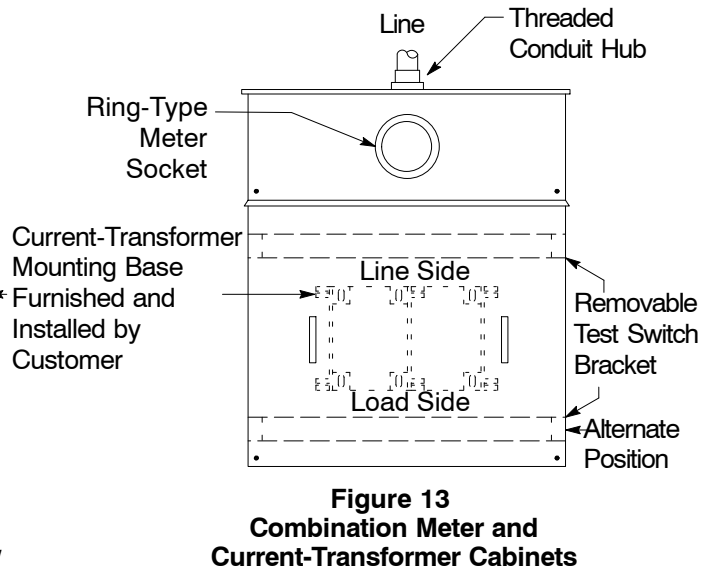

Figure 13
Combination Meter and
Current-Transformer Cabinets
0-400 Amp Rating
For 277/480 V, 3 ϕ , 4-Wire Wye
(See Table 1, Footnote 6 on Page 5)

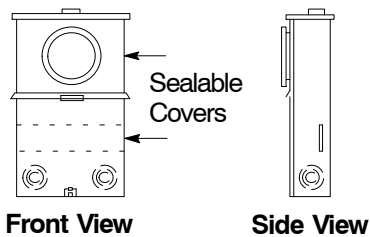

Figure 14
Meter Box for Transformer-Rated Metering

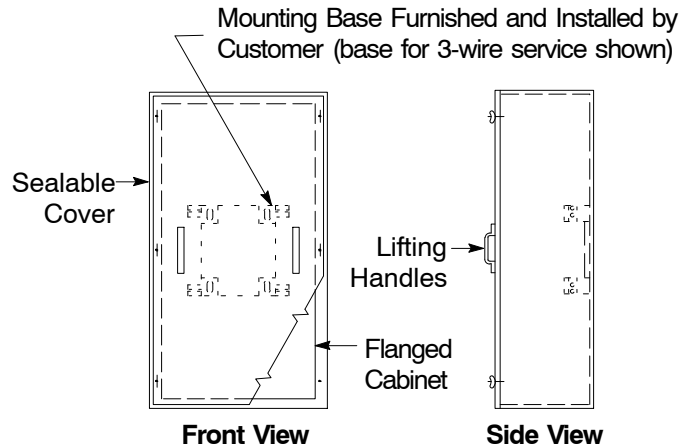

Figure 15
Current-Transformer Cabinet
0-400 Amp Rating

Revision Notes

Revision 15 has the following changes:

1. Revised Table 1 on Page 5.
2. Revised Table 2 and Footnotes on Page 6.
3. Revised Note 3 on Page 8.
4. Revised Figure 8 on Page 8.
5. Deleted Item #23 in Table 5 on Page 9.