



Five Minute Meeting:



Topic: Welder ID Update in ITS Onboard for Existing and New Contractors

Date: 12/07/2021

Audience: Gas transmission (GT) general construction (GC), construction management (CM), maintenance and construction (M&C), construction as-built quality control, compliance desk, data quality management, operator qualification (OQ)

The key thing you need to know

Industrial Training Services (ITS) Onboard is a cloud-based application that stores operator qualifications (OQs) for Pacific Gas and Electric Company (PG&E or Company) employees and contractors. The welders Onboard identification (ID) card includes a quick response (QR) code that can be scanned for access to specific welder records. The Gas Qualification department has worked with ITS to improve the ID process.

- Currently, contractor welder's and/or inspectors have both stencil ID (e.g., A555) and ITS ID (e.g., HS1B3). The stencil ID is not available in ITS Onboard so they must use ITS ID for electronic access of their records.
- To bring consistency in the ITS system, the two IDs for contractors have been consolidated and all existing ITS IDs will be replaced with stencil IDs as shown in the following process flow. There is no change for company employees who have a LAN ID and existing contractor welders and/or inspectors who already have a stencil ID.

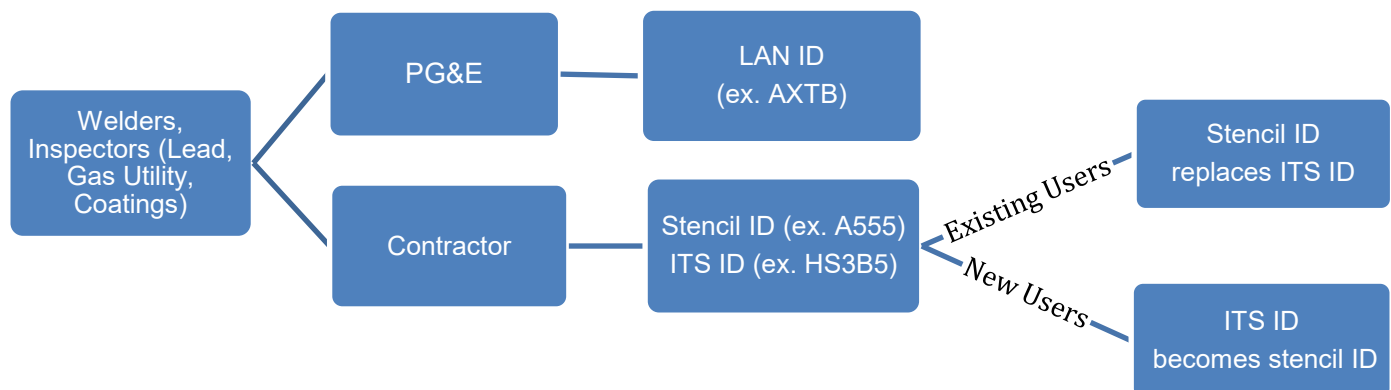

- The ITS ID will be used as the stencil ID for new users, beginning **November 1, 2021**.
- Ordering of the New Onboard ID cards will follow the existing process. Existing Onboard cards showing older ITS ID will still be valid after this change.
- Welders and/or inspectors who log on to Onboard must start using the stencil ID for their username.
- ITS reports will also show the stencil ID when all changes are complete.
- Any technical issue or conflict with use of the stencil ID will be addressed on a case-by-case basis.

INTERNAL

"PG&E" refers to Pacific Gas and Electric Company, a subsidiary of PG&E Corporation. ©2021 Pacific Gas and Electric Company. All rights reserved.



Five Minute Meeting:

Why it matters to you

To ensure the as-built records are traceable, verifiable, and complete (TVC), field personnel require access to applicable OQ records for validation and for the welder performance record that is to be included with the as-built records at the end of the project. For access to the ITS database, the welder unique identifier is the ITS ID and it is inconsistent with previous stencil ID references in the following document.

1. Job Aid TD-4160P-60-JA01, "Daily Field Weld Summary Report (DFWSR) Instructions," provides guidance as follows:
 - "Record PG&E LAN ID or contractor personnel ID of qualified person who performs welding according to his or her position recorded on the DFWSR. Examples: PG&E: J5JM; contractor: A513."
 - The existing contractor personnel ID (same as stencil ID) number cannot be used in the ITS database to retrieve welder performance records. It is time-consuming for field personnel to cross-reference the two IDs to retrieve the welder performance record, which can lead to inaccurate records.
2. To mitigate the concern described above, the current ITS ID is being replaced with a stencil ID for existing active contractors who hold a stencil ID.

Key discussion points

1. Continue to use the four-digit contractor personnel ID or stencil ID on the DFWSR, per the job aid for existing active contractors.
2. New contractor welders and/or inspectors will use the five-digit ITS ID as their stencil ID on all the documents.

Whom to contact with questions

Ronda Shupert, Manager Gas Qualifications: RFSL@pge.com