

	INSTALLATION DETAILS FOR SERVICE TO POLE-MOUNTED COMMUNICATION EQUIPMENT		027911
	Asset Type: Electric Distribution	Function: Construction	
Issued by: Genet Mengistu (GMMn) <i>Genet Mengistu</i>	Date: 6/30/2023		
Rev. #15: This document replaces PG&E Document 027911, Rev. #14. For a description of the changes, see Page 15.			

Purpose and Scope

This document illustrates the minimum design and construction requirements for providing service, supplied from overhead facilities, to non-PG&E owned antenna and communication equipment installed above or below supply lines (primary, secondary or service) on PG&E or joint distribution wood poles and wood streetlight poles.

General Information

- The preferred location for antennas to be installed is in the communication zone on the pole and not the top of the pole. Only service connections and arrangements described and shown in this document are approved design installations. Alternate connections, arrangements, or designs will not be allowed.**
- For the design and construction requirements for antenna and communication equipment installed on PG&E or Municipal owned steel streetlight poles, or 3rd party owned wood poles, served from an underground or overhead service, refer to [094677](#), [094678](#) and [094679](#) listed in the reference documents on Page 3.
- It is the responsibility of the constructor to ensure the antenna installation meets the requirements of PG&E and CPUC General Order 95.**
- Before installation, the location of the equipment and the vertical run are to be mutually agreed upon between representatives of the communication company and PG&E.
- 3rd party (non-PG&E) owned antennas and communication equipment are not allowed to be installed on poles that have PG&E distribution equipment installed and connected to the primary voltage lines. This includes the top of the pole and the communication zone. This will reduce interference on poles and allow for quicker and safer access during emergency work for the operation and replacement of equipment.**

Distribution equipment includes primary risers, cutouts, fuses, switches, transformers, capacitors, regulators, as well as any other type of equipment not listed here that is connected to the overhead primary lines.

- Primary voltage lines with triangular construction provide a safer work environment, more reliable system, and reduces the threats of fire ignition, by increasing the separation of the wires and installing them at different levels. For these reasons, **of the design and installation of antennas on existing pole tops where the primary voltage lines are built with triangular construction are not allowed.** A pole nearby that has all wires on a crossarm (flat construction) or a streetlight pole may be selected.
- Stand mounted antennas or antennas embedded in or attached to communication cables and messengers must have a minimum radial clearance of 6 feet from the edge of the pole. If the Minimum Approach Distance (MAD) for the antenna is greater than 3 feet than the radial clearance must be increased.
- SmartPole Metering is required for service. Refer to [094675](#) listed in the reference documents on Page 3 for the SmartPole metering options and requirements. For loads that exceed 100 amps contact the local service planning office for alternate metering requirements.
- The metering provision contained herein is an exception to the Greenbook requirement and is designed primarily for CATV power supplies and other telecom equipment requiring metering.
- The metering equipment must be mounted on the same pole as the PG&E service, antenna, and communication equipment. **Remote metering is not allowed.**
- When pole metering is unacceptable because it does not meet the PG&E criteria and requirements, the alternative method is to install approved pad-mounted pedestal metering served from a PG&E underground service. Some examples of unacceptable situations include locations:
 - Where access to the meter is impaired.

Installation Details for Service to Pole-Mounted Communication Equipment

- Where meters may be subject to obvious traffic hazards or unsafe working conditions.
 - Where hillside pole locations render metering unsafe.
 - Where there are only PG&E underground facilities and no overhead primary and secondary distribution facilities.
12. The potential exists for governmental entities to inquire as to metering for traffic or surveillance cameras, or possibly lighting load if mounted on PG&E or joint poles. In all cases, field representatives shall request the telecommunication company to provide documentation that authorizes them to occupy the space on the pole (e.g., contract permit issued by PG&E or joint owner for tenants).
 13. The pole-mounted antenna and communication equipment loads will only be served at single-phase, 2-wire, 120 V or a single-phase, 3-wire, 120/240 V service.
 14. The requirements in this Engineering Document are typically updated annually. The requirements become effective on the date of the publication. New changes may affect the customer's preliminary designs and selected pole location as submitted on their application. This includes application submittals that are up to, or more than, 12 months old. As described in Greenbook section [1.4., Changes in Requirements](#), PG&E may revise its design and construction documents up to the date the applicant's service design is approved and signed-off by PG&E. Applicants that have not been provided a PG&E approved design, or if the approved design is older than 12 months, are subject to newly published requirements.
 15. If changes are made to an existing antenna installation that requires the pole to be replaced for any of the following reasons, then all requirements in this document must be met. Including Note 5 where the antenna would be required to be removed from a pole with distribution equipment connected to the primary lines.
 - A. Pole loading is exceeded.
 - B. Minimum clearances will not be met.
 - C. The PG&E service and SmartPole meter are upgraded to handle a larger ampacity due to increased loading.
 - D. The PG&E meter is remote at another location and not attached on the same pole or in a pad-mounted pedestal. Remote meters are not allowed and must be brought to current standards.
 16. Pole steps shall be placed so that runs or risers do not interfere with their free use. Attention is directed to the following requirements of [General Order \(G.O.\) 95](#).
 - A. The position of the climbing space shall not be shifted more than 90° around the pole within a vertical distance of less than 8 feet. Refer to [Rule 93](#) of [G.O. 95](#).
 - B. Vertical runs are not permitted in climbing spaces through conductors in rack construction.
 - C. Vertical runs of supply lines shall have a clearance of not less than 1-1/2 inches from vertical runs of communication lines.
 - D. The coaxial cable leads to and from amplifier units shall not be carried under the same protective covering with the 120/240 V supply conductors. The leads should be carried outside the molding in cable rings. The leads are not required to be covered unless they are within a vertical distance of 3 feet above or 6 feet below unprotected supply conductors.
 - E. The ground wire is required to be covered.
 17. Units shall be fused or otherwise protected against short-circuit currents. A fused switch or circuit breaker, approved for service entrances, is required. Communication type fuses and fuse holders are not satisfactory means of disconnecting the power source.
 18. Power Supply Units: Power supplies, or any amplifier which has or is connected to a backup power supply, must have a disconnecting device to separate it from PG&E's system. Power units are to have the communication company's name and emergency phone number on them.
 19. Antennas: Antennas installed on distribution poles must have an ownership label with a contact number, site identification information, and a disconnect switch which will shut off RF transmission. The disconnect switch is to be used in an emergency when the normal practice of arranged power-down cannot be accomplished. Locate the ownership label above the SmartPole Meter and not greater than 15 feet above grade. See the requirements in item 18.C. Signage, on Page 5.
 20. Clear and level working space is required in front of the meter. This clearance is 36 inches deep x 30 inches wide and extending from grade up to a minimum of 12 inches above the meter. The working space may not be sloped, have ramps, or any obstructions.

Installation Details for Service to Pole-Mounted Communication Equipment

21. To ensure proper climbing space and clearances are maintained around poles, a minimum horizontal clearance of 4 feet from PG&E poles and metering equipment to non-PG&E street signs on posts or poles, or any other obstructions is required.
22. Antennas and communication equipment will not be allowed on poles that have permanent non-PG&E street signs attached if the signs restrict the pole climbing space and the working space around metering equipment.
23. Antennas and communication equipment will not be allowed on PG&E poles that are less than 10 feet away from a non-PG&E pole. This includes streetlight and non-streetlight poles.
24. Antennas and communication equipment on a streetlight pole must not block or impede the illumination projecting (throw) from the streetlight fixture (luminaire). For specific requirements see document [TD-092817-B002 Streetlighting Design Restrictions: Mounting Apparatus below Streetlights](#).
25. PG&E meters must not be installed on poles that are in traffic medians or traffic islands where vehicle thoroughfares are on more than one side of the pole. Refer to document [094675](#).
26. Shrouds that surround antennas on pole tops must be a minimum 1" from top of pole for compliance inspections.

References	Location	Document
"Procedures for Working Around Antennas SmartPole Meter for Service to Pole-Mounted Communication Equipment"	TIL	TD-2001P-01
Service to Communication Equipment on PG&E Owned Steel Streetlight Poles with Antenna Provisions	TIL	094675
PG&E Metering and Service Connections For Non-PG&E Owned Steel Streetlight Poles With Antenna and Communication Equipment	TIL	094677
PG&E Electric Service and Metering For Communication Company Equipment and Antennas on Non-PG&E Telecommunication Owned Poles	TIL	094678
Notification of Abnormal Conditions Caused by Third-Party Utility	TIL	094679
Moldings, Conduits, and Attachments for Use on Wood Poles and Crossarms	OH: Risers/ UG-1: Terminations	TD-2014S
Requirements for Customer-Owned Poles Compression-Type Connectors for Overhead Distribution and Transmission	OH: Conductors	021924
Fired Wedge Connectors for Primary and Secondary Distribution Lines	OH: Services/Greenbook/EMWP	041010
	OH: Conductors	066194

Design and Construction:

27. The following requirements apply to antennas installed on solely owned, jointly owned, wood distribution poles.
 - A. Antennas above supply lines: Third party antennas are only allowed above supply lines or at pole top (above supply facilities) under a license agreement and in accordance with the design and construction requirements outlined herein.
 - B. Antennas below supply and/or communication lines: Third party antennas are allowed in or below the communication space on joint use poles in accordance with the design and construction requirements outlined herein. When the requesting party is a member of the NCJPA and requests attachment to a PG&E solely-owned distribution wood pole, that party is required to submit a joint pole preliminary Form 2 intent. When the requesting party is not a member of the NCJPA, they must obtain a license agreement for pole attachments. Refer requests from non-members to PG&E's New Revenue Development Department (NRD).
 - C. PG&E owned antennas: Antennas associated with PG&E's SCADA system or the SmartMeter™ project shall be installed in accordance with the applicable engineering documents; [054422](#) PG&E Overhead SCADA and PDAC Installation, [068190](#) Antenna and DCU Installation Details for SmartMeter™ Network, [072145](#). SmartMeter™ Electric SSN Network Nodes on Distribution Infrastructure.

Installation Details for Service to Pole-Mounted Communication Equipment

D. Third party antennas are not allowed on streamline poles. PG&E owned antennas are allowed on streamline poles on an exception basis when no other options are available.

E. Any antenna communication equipment or combination of equipment that exceeds 18" in height must be stood off a minimum of 4" from the surface of the pole to facilitate climbing.

28. Design and Construction Requirements for 3rd Party Antennas on Distribution Poles; Above or Below Supply Lines.

The following requirements apply to antennas installed on joint use poles supporting circuits up to 50 KV and are in accordance with G.O. 95 Rule 94. Antennas and their related crossarms, brackets, hardware, risers, control boxes, etc. shall meet the requirements detailed below.

A. Clearances (Also see illustrations in Figure 6 through Figure 10)

- (1) Antennas and supporting elements (e.g. crossarms, brackets) shall maintain a vertical clearance of 6 feet below Supply Conductors operating at 0 – 50kV.
- (2) Antennas and their support elements (e.g. crossarms, brackets) shall maintain a 2 ft. vertical separation from communication conductors and equipment. Antennas may be installed above or below communication conductors as long as the installation complies with the clearance requirements outlined in items (1) and (3) of this section.
- (3) Antennas, associated equipment (e.g. terminations, enclosures) and their support elements installed above supply lines and/or communication lines of different ownership shall maintain vertical clearances as specified in Rule 38 Table 2, Case 21 Columns A–H. These requirements are summarized below.
 - (a) Minimum vertical clearance of antennas and associated support elements from:
 - (i) Span wires, guys and messengers – 2 feet
 - (ii) Communication conductors – 2 feet
 - (iii) 0–750 volt conductors including service drops – 4 feet
 - (iv) 750–35,000 volt conductors – 6 feet
 - (b) Notes:
 - (i) Vertical runs or risers associated with the antenna(s) may terminate 1 foot below the antenna or support element for conditions (a) (i) or (a) (iii) above.
- (4) Antennas, associated equipment and support elements, installed above supply or communication lines, shall maintain radial clearances from unattached supply and communication lines as specified in Rule 38, Table 2 Case 3. These requirements are summarized below.
 - (a) Minimum radial clearance of antennas, equipment and associated support elements from:
 - (i) Span wires, guys, messengers and communication conductors – 2 feet
 - (ii) 0–750 volt conductors including service drops – 4 feet
 - (iii) 750–7,500 volt conductors – 4 feet
 - (iv) 7,500–20,000 volt conductors – 6 feet
 - (v) 20,000 – 150,000 volt conductors – 8 feet
 - (vi) Above 150KV see G.O. 95.
 - (5) Antennas shall maintain a 2 foot horizontal clearance from centerline of pole when installed between supply and communication lines or below communication lines.
 - (6) There is no horizontal clearance from centerline of pole for antennas installed between supply lines or at the top of the pole, but the antenna and support elements must be arranged so that the pole can be safely climbed.
 - (7) Antennas shall have a vertical clearance above ground as specified in Table 1, Column B Cases 1 to 6a of G.O. 95. This requires antennas that overhang buildings, walkable surfaces, roadways etc. meet the same vertical clearance requirements as communication conductors.

B. Climbing Space must be maintained except for the allowable climbing space obstructions. Reference G.O. 95 Rule 54.7 A (3). Antennas, associated equipment and support elements are not allowed in the climbing space. When antennas are installed above supply lines at the top of the pole, climbing space must be maintained to:

Installation Details for Service to Pole-Mounted Communication Equipment

- (1) The bottom of the antenna (including associated support elements) if affixed less than 8 inches from the surface of the pole.
- (2) The top of the pole or pole top extension if the antennas are affixed more than 8 inches from the surface of the pole or pole top extension.

Note: Climbing space can be difficult to maintain with antenna installations due to antenna size, number, configuration, and orientation on the pole. In addition, most installations have multiple risers and vertical runs, grounds, equipment and metering enclosures. As always, good communication, up front, is essential to ensure adequate space is available to accommodate the antenna and all the associated equipment.

- (3) Pole Steps: Stepping must be in accordance with Rule 91.3. No pole steps are to be installed in the supply space or above supply lines except for any necessary steps associated with a pole top extension bracket.
- (4) Risers, grounds and vertical conductor runs on non-metallic structures:
 - (a) Risers, grounds and vertical runs passing supply lines and/or communication lines and/or their associated equipment shall be suitably covered throughout their length, shall be installed outside the climbing space and shall be constructed and maintained in accordance with Rule 54.6-D 1, 2, 3, and 5 (requirements for vertical runs for supply lines).
 - (b) The suitable protective covering (see Rule 22.8) for risers, grounds and vertical runs passing supply lines and/or equipment shall extend no less than:
 - (i) 3 feet above lines energized from 0 – 750 volts
 - (ii) 6 feet above lines energized from 750 – 35,000 volts
 - (iii) 9 feet above lines energized from 35,000 – 50,000 volts
- (5) Risers, grounds and vertical conductor runs on metallic structures that pass supply lines and/or communication lines and/or equipment shall occur on a single structure and shall be installed outside the climbing space in accordance with Rule 54.6-D4.

C. Signage: Poles shall be marked with a sign or signs for each antenna installation. The sign shall contain the following information and placement.

- (1) Name / identification of the antenna operator
- (2) A 24-hour contact number of antenna operator for emergency notification or other information
- (3) Unique identifier of the antenna installation
- (4) Indication that the antennas RF output is in compliance with the FCC General Population (G.P.) uncontrolled exposure limits or, if the antenna exceeds those limits indication of the minimum approach distance. See Utility Procedure [TD-2001P-01](#) Procedures for Working Around Antennas for examples of typical RF signage.
- (5) Located above the SmartPole Meter and not greater than 15 feet above grade.

D. Disconnect switch

- (1) Antennas that exceed the FCC's General Population (G.P.) Uncontrolled Limits
 - (a) Require the antenna owner to provide a disconnect switch that is readily accessible to PG&E. This switch must de-energize all sources of power to the antenna, both AC and any battery backup.
 - (b) Require the antenna owner to establish a protocol, agreed to by PG&E, for powering down the antenna site.
 - (c) Will be operated by mutual agreement except during emergencies.

Note: Minimum Approach Distances (MADs) must be indicated on the antenna signage.

- (2) Antennas that meet the FCC's General Population (G.P.) Uncontrolled Limits
 - (a) Do not require a disconnect switch for these low power antennas.
 - (b) Require the wireless company to submit documentation indicating the maximum RF output of the antenna meets the FCC requirements for General Population/Uncontrolled RF exposure.

29. Notification of Conditions to Third Party Utility: If an existing antenna installation is found that does not meet the design and construction requirements detailed in 1 thru 7 above, a 3rd party notification (Form -3447) should be

Installation Details for Service to Pole-Mounted Communication Equipment

created. Typical problems involve antennas, risers or other equipment installed in the climbing space, inadequate clearances or signage, and antennas installed in the Safety Clearance Zone on joint poles. These conditions present a hazard for workers and must be corrected within the timelines described in Utility Standard [TD-2014S](#) Notification of Conditions to Third-Party Utility.

Also see the, Design and Construction Checklist for Third Party Antennas, for requirements and typical deficiencies.

30. Design and Construction Requirements for Antennas and Other Equipment on Streetlight Poles

A. Antennas and other equipment on PG&E-owned streetlight poles

- (1) PG&E will not sell ownership interest in a streetlight-only pole. Third party attachments, antennas or other equipment (see note below) may be permitted under a license agreement. Requests from a NCJPA Member to become a joint pole owner (for streetlight only poles), via Form 2, should be rejected. Refer all requests to PG&E's NRD Department.
- (2) Licensing for third party antennas, gunshot detectors, government owned cameras, and other equipment will be managed by PG&E's NRD Department. Consult with NRD and Electric Distribution Standards for the applicable design, construction and other requirements.
- (3) Where applicable, un-metered attachments to streetlights must also meet the requirements outlined in Form 79-1078 – Agreement for un-metered electric service to devices connected to Pacific Gas and Electric Company's streetlight facilities.
- (4) Antennas are not allowed on poles with decorative, semi-decorative, or "Special facility" streetlights that the customer has chosen from our appliance product mix or outside of the normal product mix. Exceptions may be allowed when the streetlight customer of record states, in writing, that they have no objection to the installation. Refer any requests to PG&E's New Revenue Development (NRD) Department.

31. Antennas on customer owned streetlight poles.

A. Antenna projects involving customer owned streetlight poles will be managed by PG&E's. Streetlight Program Manager. Streetlight poles installed under the following rate schedules are not owned by PG&E therefore any requests for attachment should be directed to the pole owner.

- (1) LS-1C, Customer owns pole and foundation
- (2) LS-2A, B, and C
- (3) OL-1

B. Where the requesting party wants to attach to a PG&E owned streetlight mast arm on a customer owned pole, a letter of approval must be acquired by the requesting party from the PG&E customer receiving lighting service.

C. A separate energy connection for the antenna must be made under the governing tariff in absence of any special CPUC approved agreement. The 79-1048 agreement (and Rate Schedule LS-2) allows antennas on city owned streetlight poles to utilize the streetlight photo control receptacle as the energy source where the installation meets the loading limitation and all other requirements of the agreement.

Table 1 Bill of Material to Be Furnished by the Communication Company

Item	Description
1	Conduit, Rigid, PVC, Schedule 80 ¹ (size as required)
2	Pipe Straps, Galvanized
3	Conduit Fittings (as required)
4	Wire, 600 V, Size as Required
5	Service Weather Head, PVC
6	SmartPole Meter Enclosure 094675 , as required
7	Steps, Pole (if pole is unstepped)

¹ Use Schedule 80 for 1-1/2" or smaller, or Schedule 40 for 2".

Installation Details for Service to Pole-Mounted Communication Equipment

Table 2 Bill of Material to Be Furnished and Installed by PG&E

Item	Description	Code	Document
8	Connector, Compression or Wedge (as required)	-	041010
9	Conduit, Rigid, PVC, 2"	360234	021924
10	SmartPole Meter, Watthour (as required)	-	-

Note

1. Unmetered load may be 2-wire, 120 V or 3-wire, 120/240 V.
2. When a SmartPole Meter is required refer to TD-027911B-002 SmartPole Meter for Service to Pole-Mounted Communication Equipment.

Installation Details for Service to Pole-Mounted Communication Equipment

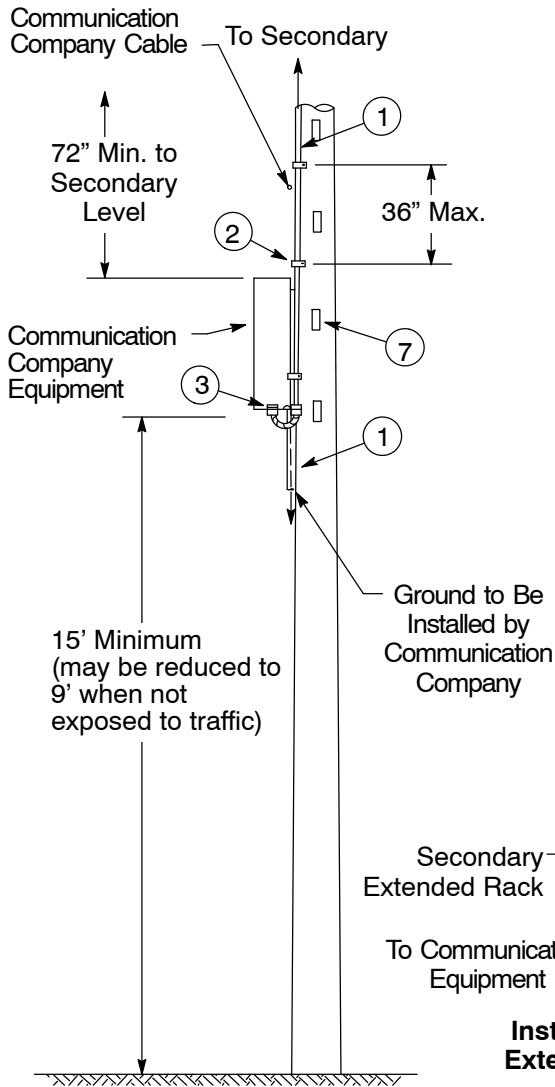

Figure 1
Unmetered Service Connection to Communication Equipment

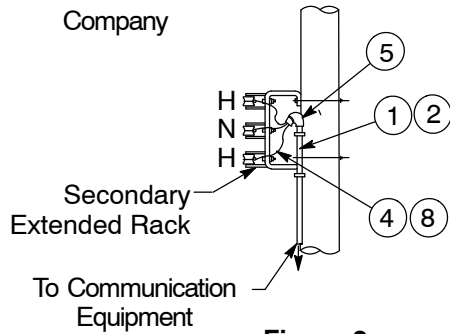

Figure 3
Installation With Existing Extended Rack Secondary

Note: New Extended Rack Construction is not allowed

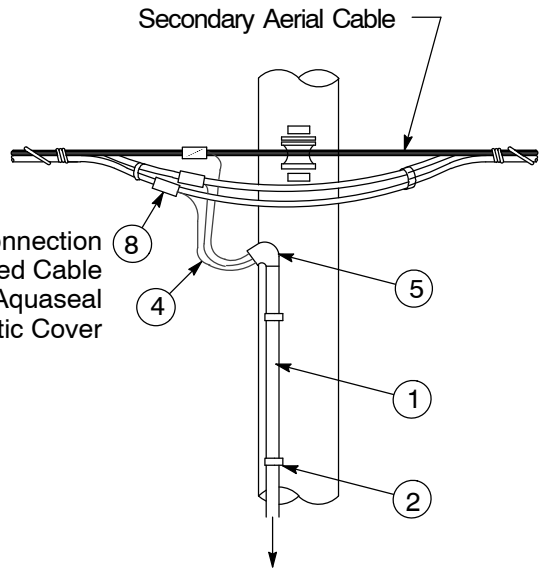

Figure 2
Installation With Aerial Cable Secondary

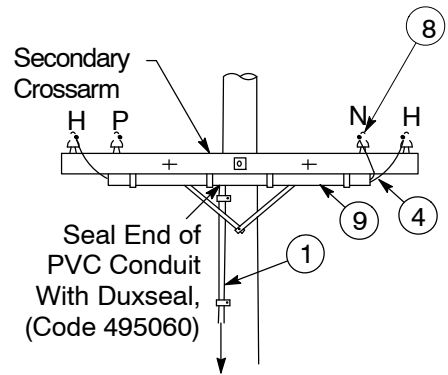

Figure 4
Installation With Crossarm Secondary

Installation Details for Service to Pole-Mounted Communication Equipment

Notes

1. For poles close to curbs avoid exposure to equipment and personnel. It is best to place the meter on a side of the pole away from traffic. If this cannot be done, the following conditions must be met:
 - A. The meter must be no closer than 4 feet to a curb to provide safe access and reading.
 - B. If the meter panel extends to the side past the pole, it cannot be closer than 1 foot to a curb.
 - C. For meters on poles next to driveways or roads without curbs see Section B-B (Driveway or Road without Curb) and associated notes on Page 9 .

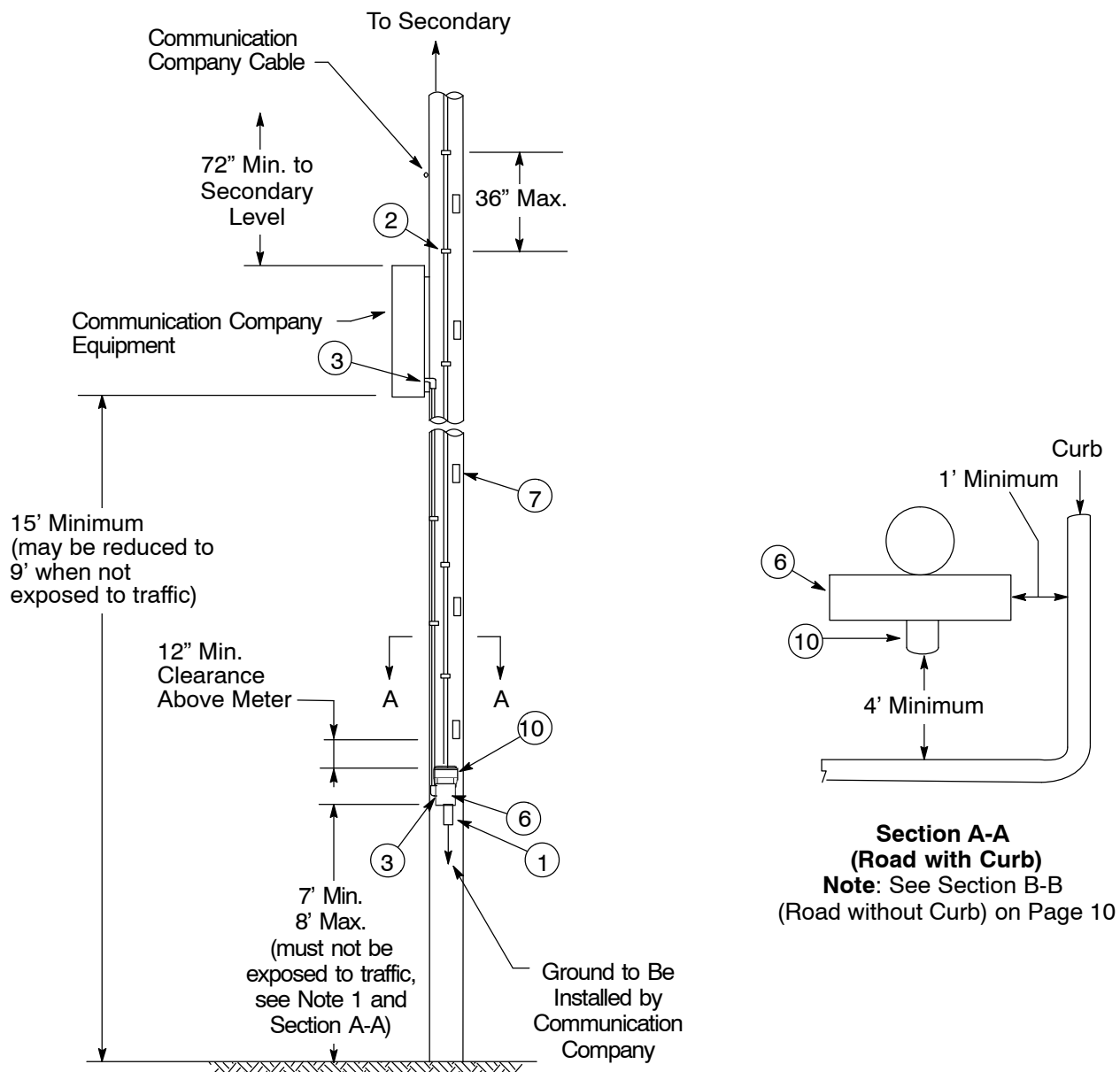

Figure 5
Pole-Metered Service Connection to
Communication Equipment

Installation Details for Service to Pole-Mounted Communication Equipment

Notes

For poles next to roads that have no curb, rolled curbs, sidewalk or curb ramps, driveways, including the driveway apron (approach), or other type of non-curbed vehicle entrance, avoid exposure to equipment and personnel by placing the meter panel on the back side of the pole away from the road or vehicle entrances. The meter panel can only be placed in the 12 O'clock position, between the 9 to 12 O'clock position, or between the 12 to 2 O'clock positions. The meter panel must not extend out past the parallel planes of the pole. The following must also be met.

1. If a driveway, alley, or roadway is a minimum of 1 foot from the edge of a pole the meter panel can only be installed on the opposite side of the pole if all other requirements are met.
2. Be closer than 8 feet (96 inches) from adjacent roads or non-residential driveways.
3. Be closer than 4 feet (48 inches) from residential driveways or sidewalk ramps.

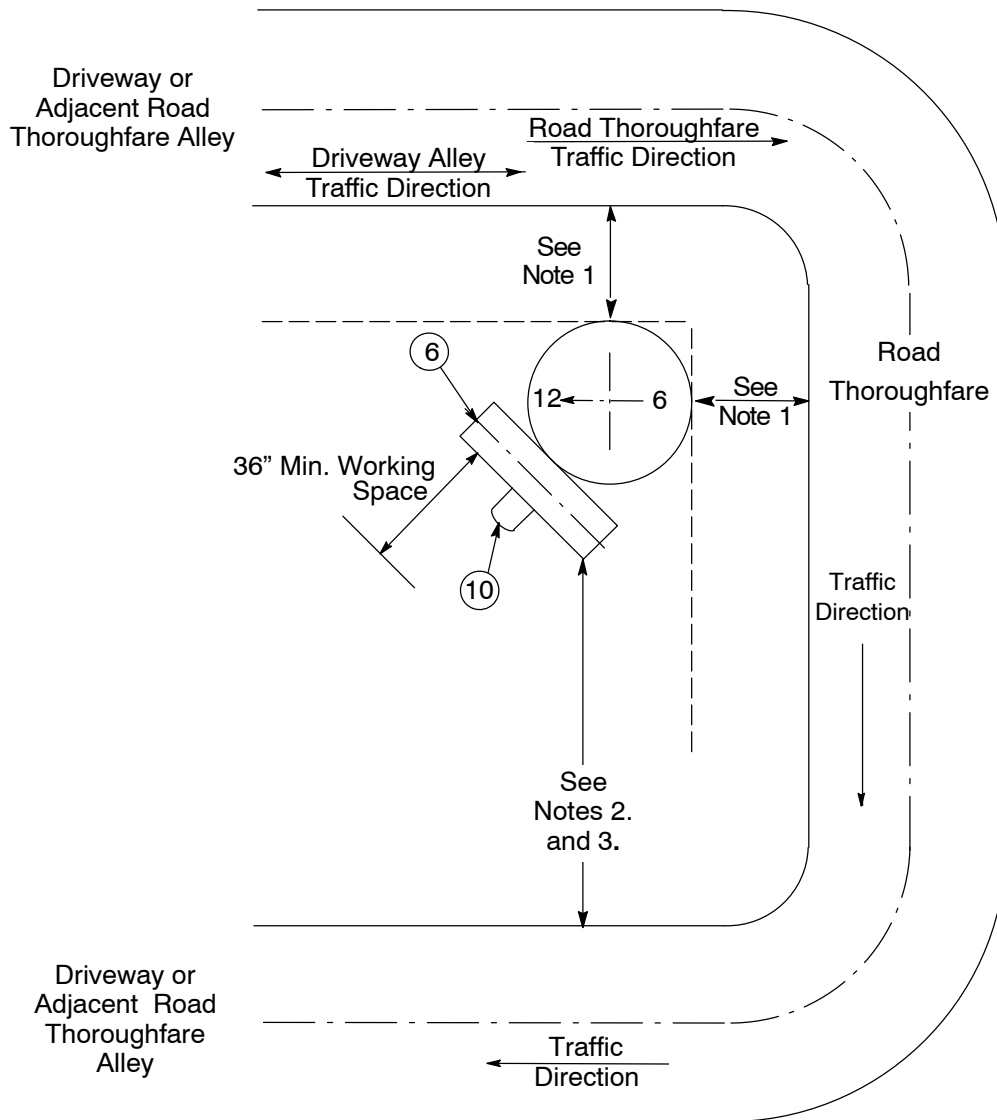

Section B-B
(Driveway or Road without Curb)

Installation Details for Service to Pole-Mounted Communication Equipment

Notes

1. Consideration should be given on reserving additional space (> 6 Ft.) for proposed or future installation of PG&E wires and equipment.

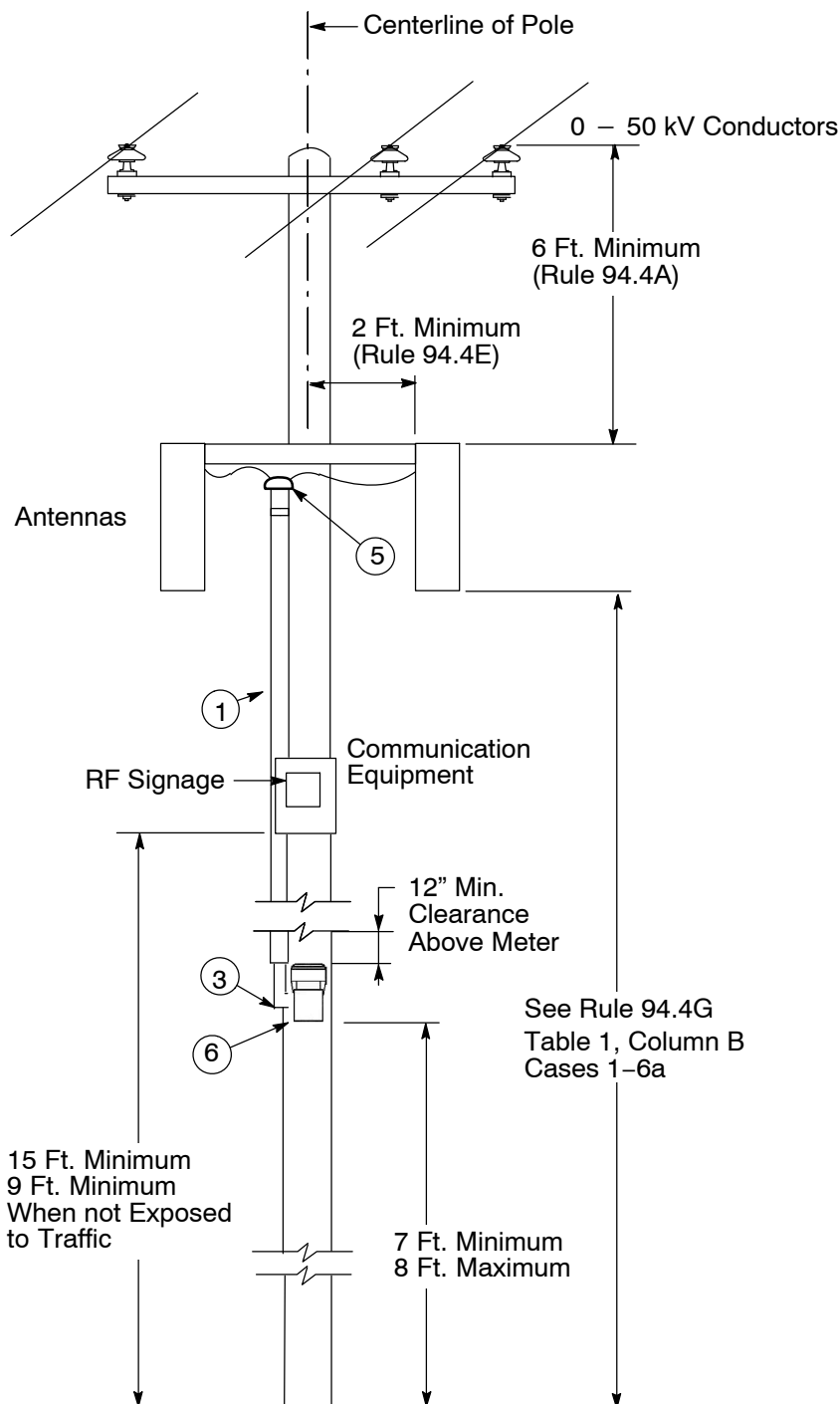

Figure 6
Antenna - Below Supply Lines

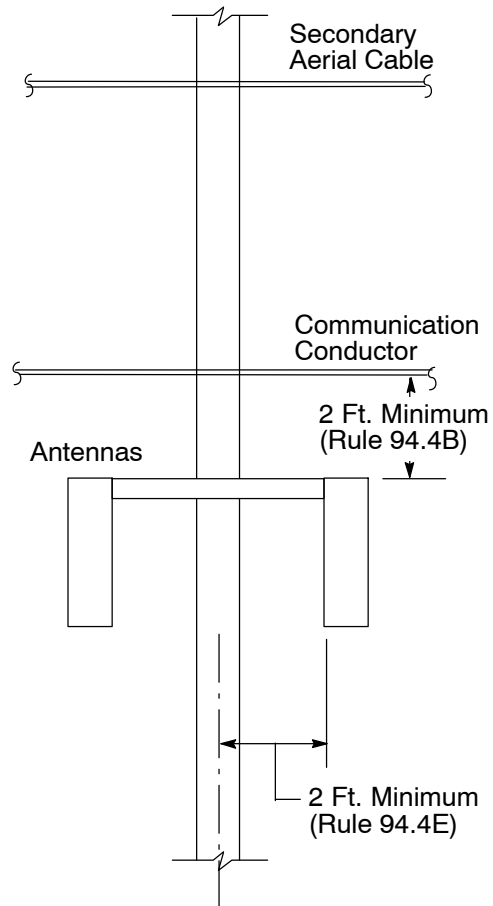

Figure 7
Antenna - Below
Communication Lines

Installation Details for Service to Pole-Mounted Communication Equipment

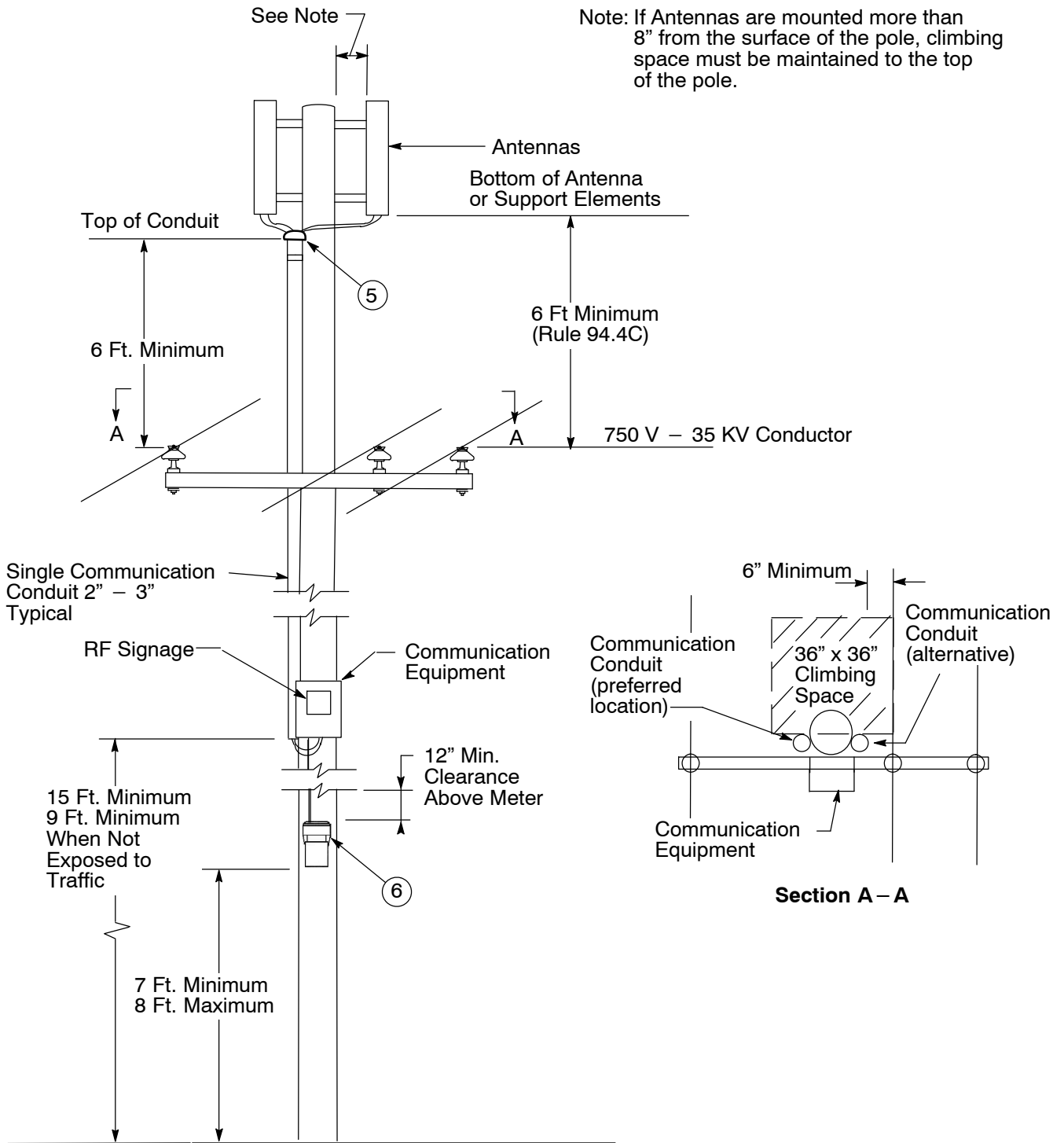

Figure 8
Pole Top Antenna – Single
Communication Conduit Run

Installation Details for Service to Pole-Mounted Communication Equipment

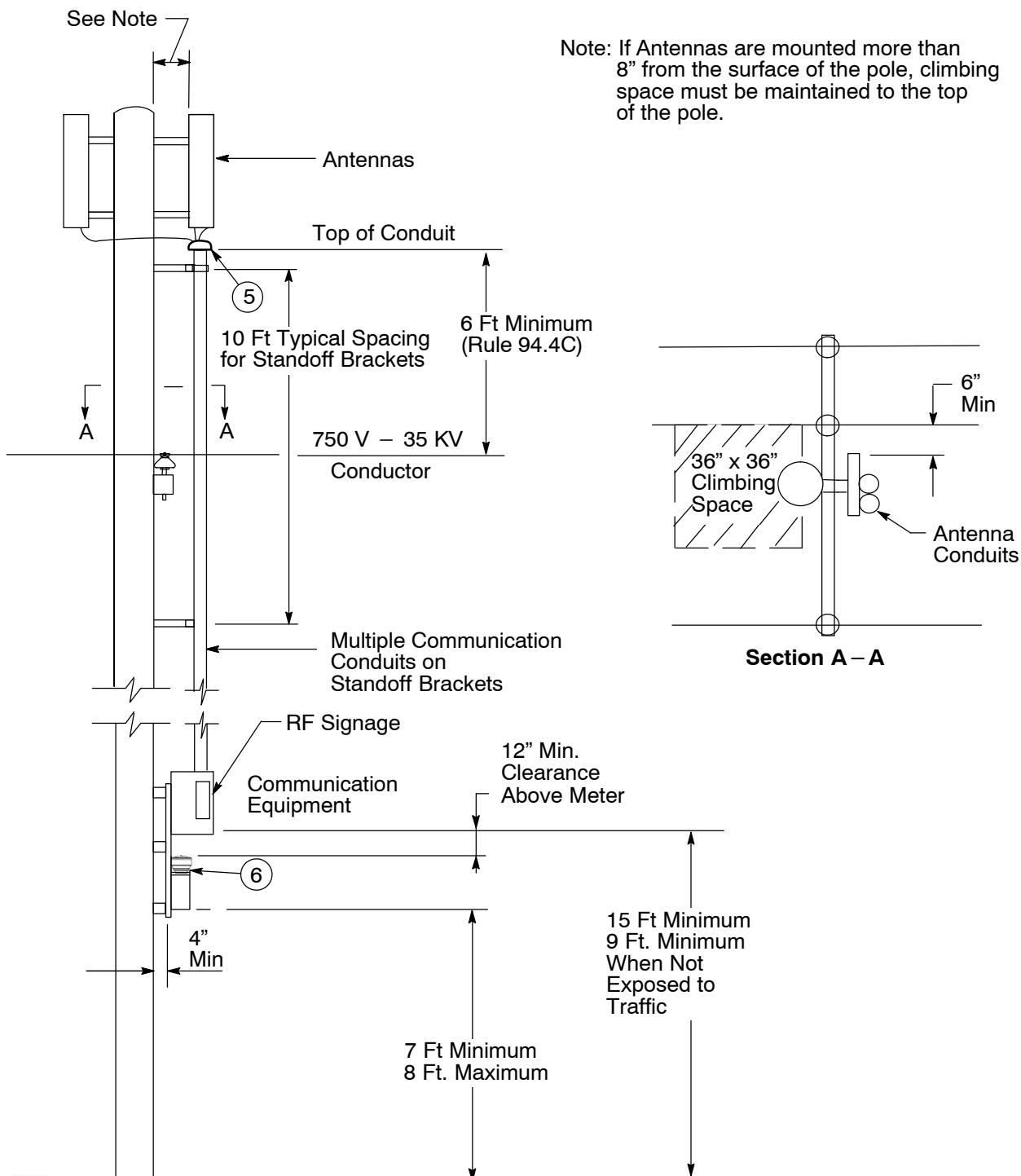

Figure 9
Pole Top Antenna – Multiple Communication Conduits on Standoff Brackets

Installation Details for Service to Pole-Mounted Communication Equipment

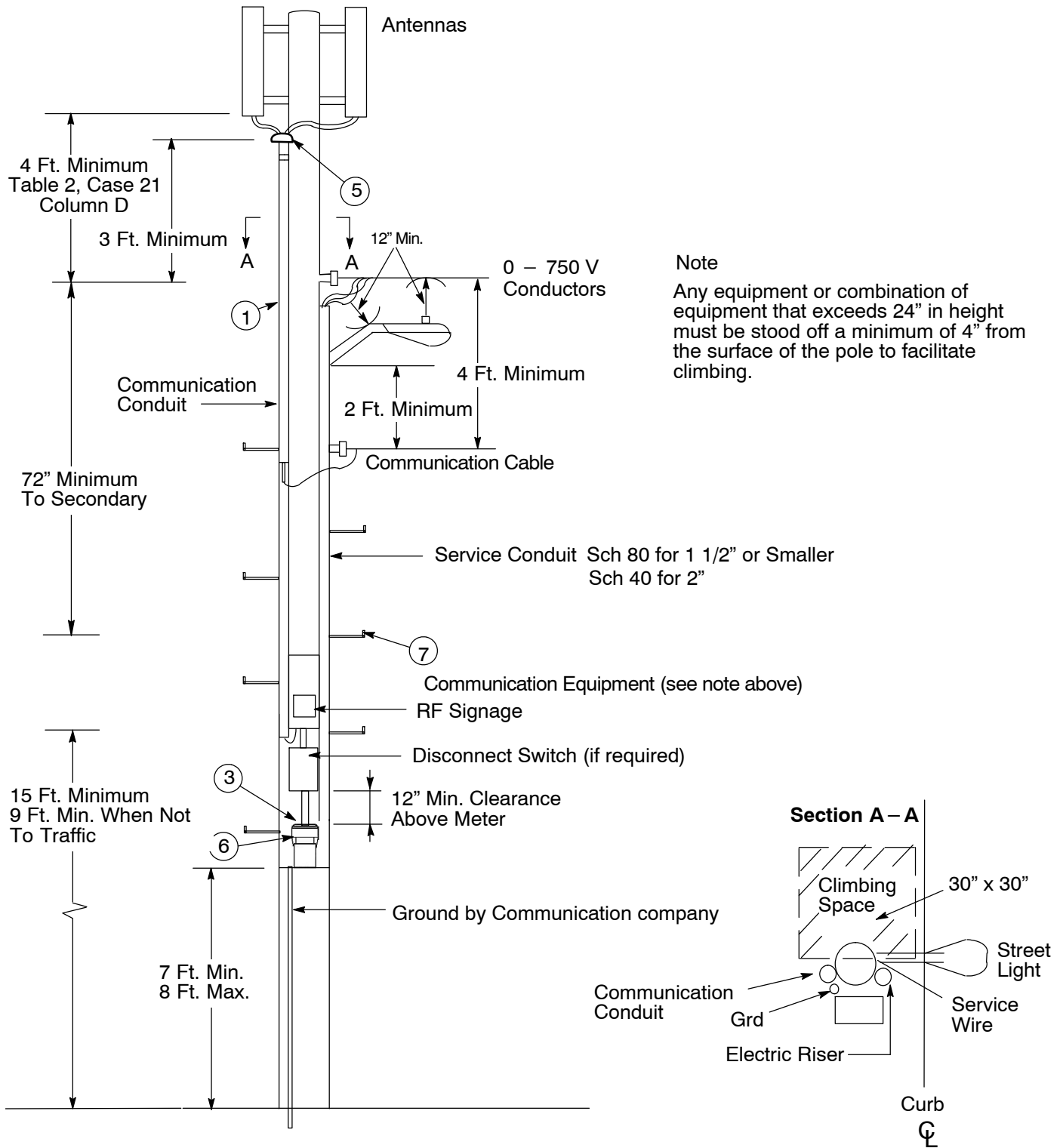

Figure 10
Pole Top Antenna - Streetlight Only Poles

Installation Details for Service to Pole-Mounted Communication Equipment

Revision Notes

Revision 15 has the following changes:

1. Owner changed to Genet Mengistu.
2. Added Note 20 on Page 2. Renumbered notes.
3. Revised Note 21 on Page 3.
4. Added Note 26 on Page 3.
5. Removed Note 28.A.(3)(b)(ii) on Page 4.
6. Revised Section B-B on Page 10.