

Section L1-T: REVENUE-METERING REQUIREMENTS FOR TRANSMISSION-ONLY AND LOAD-ONLY ENTITIES

PURPOSE

The purpose of this section is to help transmission Load Entities and Transmission Entities satisfy ISO (and PG&E as applicable) revenue-metering requirements for measuring and registering electric power supplied to them. The revenue-metering requirements in this handbook can also be found in the [CAISO Tariff](#) which may be obtained from the [ISO website](#).

Loads connecting to the ISO Controlled Grid shall be in accordance with the relevant metering protocols established by the ISO, or prior to establishing of such protocols, the metering requirements established by PG&E, the Participating Transmission Owner (PTO). Any exceptions to this section shall be addressed on an individual case basis and must be approved by the ISO. These arrangements may involve Special Facilities with PG&E, and other operating or service agreements, as approved by the ISO and local governing authorities.

L1-T.1. REVENUE-METERING REQUIREMENTS FOR LOAD ENTITIES AND TRANSMISSION ENTITIES CONNECTING LOAD TO THE PG&E TRANSMISSION SYSTEM

For purposes of this section, metering requirements for transmission service are differentiated into two basic types: Wholesale Service and Retail Service. (See Glossary)

L1-T.1.1. Wholesale Service

For wholesale transmission service interconnections, the Load Entity or Transmission Entity at its expense shall normally provide, install, own and maintain all revenue-metering related equipment, and associated communications devices. Additional details are similar to those shown in [L1-T.1.2](#) "End User".

Such wholesale entities must meet the metering requirements of the ISO, and must enter into a Meter Service Agreement (MSA) with the ISO. The MSA covers the obligations regarding retrieval of load data and accessibility by the ISO.

The wholesale entity is obligated to ensure the meters are certified and comply with ISO meter standards and accuracy requirements.

L1-T.1.2. End User (Retail Service)

End Users receiving transmission service are segregated into two service categories:

- [Bundled Service](#)
- [Direct Access \(DA\)](#)

In general, a) the meters and associated equipment shall meet the (technical) requirements of the ISO, while b) responsibilities and potential providers (such as Meter Service Provider and Meter Data Management Agent) shall be in accord with CPUC [Rule 22](#).

L1-T.1.2.1. Bundled Service

PG&E, as supplier of energy, will, at entity expense, provide, install and maintain the meter and any associated communications equipment, and shall ensure meter meets PG&E's revenue metering requirements.

PG&E responsibilities generally include the Energy Service Provider ([ESP](#)), MSP, and MDMA service:

- ensure all such entities are metered
- ensure meter meets PG&E's standards including accuracy requirements, and approve and certify the meters
- provide access to revenue metering data
- provide end-user meter data as requested
- install, own and maintain meter(s)
- read meters, process meter reading data, render monthly bills, and collect & process payments.

Load Entity or Transmission Entity responsibilities:

- Provide mounting structures, enclosures, conduit, install wiring (PG&E will make connections).
- Make arrangements (with local phone company) for communications circuits as required by PG&E as described in more detail in L1-T.3, Communications Circuits, below.
- Provide additional equipment as shown in L1-T.1.3 below.

L1-T.1.2.2. Direct Access Service

The DA Entity must select an energy supplier and may select a qualified ESP for various additional related services or provide those services themselves if qualified. The entity is responsible either directly, or through their ESP, to provide, install, and maintain the meter and any associated communications equipment, and shall ensure meter meets ISO standards and requirements:

Load Entity (or ESP) responsibilities:

- enter into a Meter Service Agreement with the ISO
- ensure all such entities are metered
- ensure meter meets ISO standards including accuracy requirements, and approve and certify the meters

- provide access to revenue metering data
- provide ISO with end-user meter data
- submit end-use meter data as per ISO protocols
- must install interval meters unless exempt due to small size (less than 50kw). (Such loads seldom qualify for transmission service.)

Note: an interval meter with communication and telephone line access must be capable of reading and storing electric consumption data in conformance with CPUC specifications. Such data must also meet ISO accessibility requirements. Usually a Quad 4 meter, with communications lines and telephone access are sufficient.

L1-T.1.2.3. Equipment Requirements:

The supplier of energy will provide, install, own and maintain metering transformers when they are within the Load Entity's substation.

- Metering CTs and PTs cannot have a bypass switch.
- Metering CTs cannot be switched or fused.
- Metering class PT/CTs (including Dual Winding devices) shall **not** be used for relaying purposes in the PG&E system. In particular, combination PT/CTs which are installed by PG&E or an approved meter installed by a qualified meter service provider shall **not** be connected to Load Entity's protective relays or used to provide protection of the Load Entity's owned equipment or devices. Refer to PG&E Guideline G13079 in Appendix D.
- PG&E may grant exceptions to this policy and allow a dual winding PT/CT unit to be installed. However, in this case, the customer will be required to sign a waiver absolving PG&E from liability in the event of failure of dual winding unit or improper performance of the protective equipment due to, for example, saturation of the CT in the dual winding.
- Metering transformers shall be tested by the manufacturer prior to pre-parallel inspection, and a certified transformer test report shall be provided to PG&E prior to installation. After installation, metering transformers shall be tested by the supplier of energy and a certified transformer test report shall be provided to PG&E. Periodic testing may be required for metering CTs or PTs.
- Combination revenue-metering voltage and current transformers shall be three, single-phase, combination voltage/current transformers. If PG&E is the Meter Service Provider, the entity shall reimburse PG&E for the labor cost associated with installation of the metering equipment. 063436 in Appendix D shows a typical installation of metering equipment. Consult with PG&E Meter Engineering for information on combination revenue-metering voltage and current

transformers.

- Provide and install wiring from the base of the revenue-metering transformers to the meters, in entity-supplied and installed conduits. Conduits above ground must be RSC (rigid steel conduit) and conduits below grade must be PVC (Polyvinyl chloride). PG&E will connect the wires to the metering transformers at Load Entity or Transmission Entity expense.
- Meters recorders and associated metering equipment, and communications equipment as required.

L1-T.1.3. Additional Requirements

In addition to the requirements described in the preceding, the Load Entity, whether wholesale or retail, or Transmission Entity shall provide, install and maintain or otherwise meet the following requirements:

- Foundation, structure and disconnect switches for mounting and disconnecting revenue-metering transformers (refer to Section L3.6.1). The support structure may be a pole or a platform-type structure, so long as it can support the CT/PT units. High-side revenue-metering shall have a minimum of two gang-operated, lockable disconnect devices to facilitate establishing a visual open on each primary side of the metering units. Refer to Engineering Standard 063436 in Appendix D for more information.
- The meter enclosure shall be a walk-in type enclosure owned and maintained by the load entity or Transmission Entity. The distance between the meter enclosure and the revenue-metering transformers must not exceed 50 feet to maintain the required metering accuracy. PG&E must approve any variance from this general rule. The enclosure must be located within and grounded to the substation ground grid. Access to the enclosure must be arranged so that PG&E personnel can read the meters without entering the substation yard. The enclosure must be equipped with an auxiliary 120-volt ac duplex plug, an overhead light, a light switch adjacent to the door, and a ground bus connected to the ground and mounted near the bottom of the wall where the meters are to be located.
- Meter panels specified by PG&E. Refer to the [Greenbook](#) or Engineering Standard 063436 in [Appendix D](#) of this handbook.
- All required conduits and junction boxes. A pull line must be installed in the conduit between the metering enclosure and the junction box at the base of the metering unit support structure to facilitate PG&E installing the metering unit secondary wires. Only PG&E's revenue metering wire shall be installed in the conduit between the metering enclosure and the CT/PT units. Conduits may be metallic or non-metallic. A dedicated land line into the metering enclosure is required for the revenue meter. Where land line is not available, and cellular cell signals are acceptable, the use of cellular phone is acceptable. If the meter phone line cannot be dedicated to the meter, the load entity shall obtain prior approval from PG&E's local metering group to

arrange for a line shared switch to be used with the meter being the secondary phone user. Also see Section [L1-T.3](#).

- High-voltage protection for phone lines, consult local phone company
- Grounding systems in accordance with PG&E requirements. See [Appendix D](#).
- A general-arrangement plan of the entity's substation and metering equipment must be made available to PG&E for review by the PG&E division electric meter Supervisor and the ISO, if applicable. Such review shall be in the early stages of the project, prior to approval of the Load Entity's or Transmission Entity's plan, to assure that the proposed interconnection can be metered accurately, tested and operated safely
- The entity shall also provide to PG&E a substation arrangement plan showing:

- Location and elevation drawings with dimensions for the metering support structure, dead-end structure, disconnect switches, etc.

Note: There must be sufficient clear space directly above the top of the support structure for the revenue-metering transformers, and approximately 20 feet of clear space horizontally, before and after construction, to allow the installation or removal of the metering transformers by means of a crane or boom.

The top of the metering unit portion of the support structure must not exceed 8 feet above finished grade. PG&E must approve any variance from this general rule.

- Location, elevation and detail drawings for the meter enclosure.
- Location, size and length of conduit runs for the metering conductors.
- Location of the conduit for the revenue-metering telephone line. The conduit for the telephone line must run from the meter enclosure to the nearest telephone company demarcation point.
- The location of the permanent maintenance access area reserved for use by a crane or boom truck in the event a metering unit has to be replaced.
- Station ground grid drawings.
- Other related data.

L1-T.2. Location of Revenue Metering Point

Revenue-metering must be installed at the service point which normally is at the point of ownership change. For transmission service, that is the incoming transmission voltage. More explicitly, high-side revenue-metering, at the transmission delivery voltage, is PG&E and ISO's standard installations and is required for all load entities at transmission voltage levels and Transmission Entities. Exceptions will be rarely permitted and are granted only by the ISO. An adjustment factor specified by the ISO in

accordance with their tariffs shall be applied for each stage of transformation, and line losses shall be calculated as a function of the maximum load current through, and the applicable electrical characteristics of the facilities and load.

L1-T.3. Communications Circuits

To meet the ISO and utility requirements, the Load Entity or Transmission Entity may be obligated to bring as many as four communication lines into the metering enclosure. In addition to the following, other communication requirements may apply; refer to Sections [L2](#) and [L3](#) of the Transmission Interconnection Handbooks:

- One phone line dedicated to revenue-metering. This line is mandatory.
- One basic business line, although there occasionally may be alternatives to this requirement. Contact your local PG&E representative or the ISO.
- One line dedicated for the interruptible service, if interruptible service is selected by entity.
- One line dedicated for transfer trip, if required to meet protection standards and system integrity.

Underfrequency relay and related accessories shall be required if the Load Entity qualifies for and elects an interruptible rate schedule. At entity expense, PG&E shall provide the labor and equipment required for the installation. In addition to any phone lines required for metering or other purposes, the entity shall provide and pay for an additional, separate phone line (VG36, Type 3002, 4-wire, unconditioned, Class B circuit) obtained from the phone company for this relaying. The line will terminate at the Designated PG&E Electric Control Center (see 062143 in [Appendix D](#)). See [Form L1-1](#) for assistance in properly ordering the leased alarm circuit. The alarm circuit will indicate to the operator that the load has been tripped by an underfrequency condition (see [Figure L1-2](#)). See [Figure L1-3](#) for typical underfrequency relay installation.

The Load Entity or Transmission Entity shall determine the ground potential rise (GPR). The GPR value will determine what grade of telephone cable high-voltage protection equipment is required, as well as the minimum required dielectric strength of the cable insulating jacket. The information required to determine the GPR: 1) highest calculated fault current (PG&E provides this information); and 2) ground resistance (entity determines this information).

Form L1-1

ORDER REQUEST FORM UNDERFREQUENCY ALARM CIRCUIT LEASE
TO BE REQUESTED FROM THE LOCAL TELEPHONE BUSINESS OFFICE

DESCRIPTION:

CIRCUIT: Data Quality
PURPOSE: Electric Underfrequency Trip Alarm Circuit to PG&E Operating Center.
SPECIFICATION: VG36, Class B, Type 4 Series 3002, Unconditioned, 4-Wire, Full Duplex, Data Circuit.

CUSTOMER INFORMATION:

BUSINESS NAME: _____
CONTACT NAME: _____
ADDRESS: _____

TELEPHONE NUMBER & AREA CODE: _____

PG&E COMPANY (1) Pacific Gas & Electric Company
TERMINAL ADDRESS: _____

(circuit to terminate on RJ 21 block)

PG&E CONTACT: (2) _____

TERMINAL ADDRESS: (3) _____
(Customer E-20 Site) _____

SPECIAL CONSIDERATIONS: 1. This leased circuit will enter a power substation yard. Special high voltage protection requirements should be reviewed by the telephone company's protection department.
2. All Telco and PG&E equipment will be supplied with AC power off the line side of the customer's breaker.

Figure L1-2

TYPICAL UNDERFREQUENCY ALARM CIRCUIT DIAGRAM

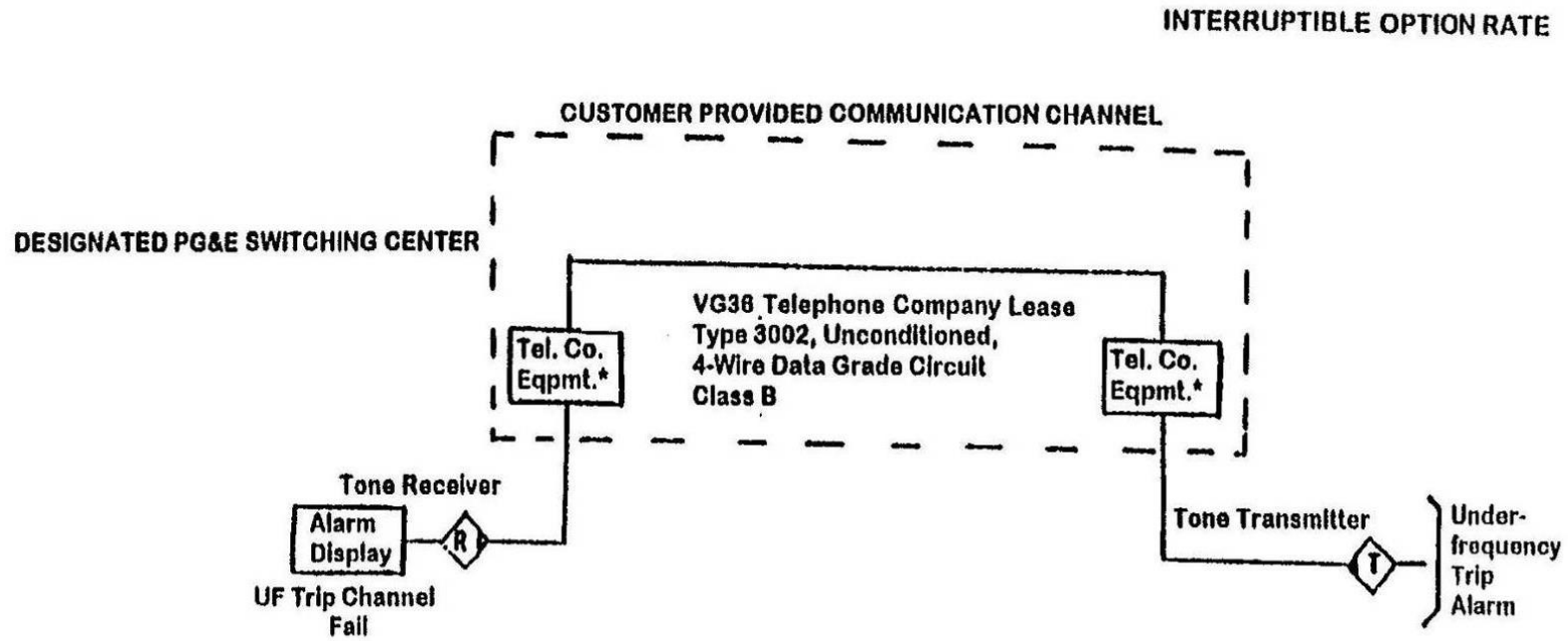

*Includes necessary protection equipment



Figure L1-3
Customer Underfrequency Relay Installation

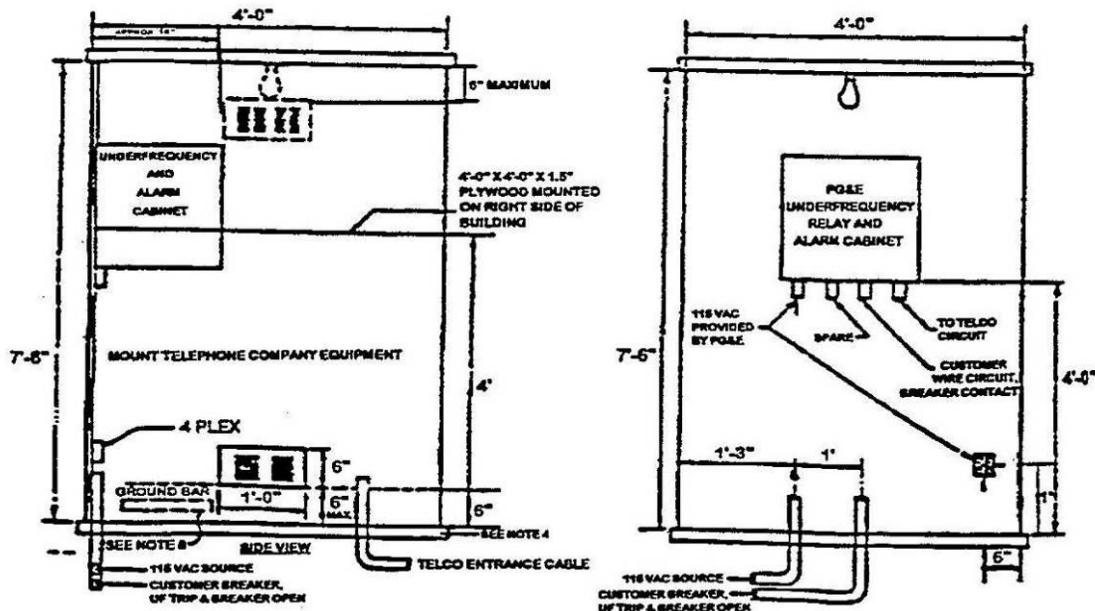

GENERAL NOTES:

1. The walk-in enclosure shall be weatherproof.
2. Provide two-screened, rain tight louvered panels approximately 50 square inches net area, located as shown to provide cross-ventilation.
3. All metallic enclosures and non-current carrying metallic parts shall be grounded in accordance with the national electric code.
4. Provide foundation suitable to the type of building construction and subject to the approval of local building codes.
5. Contractor to contact appropriate utility to determine direction of conduit stubs. All underground conduits to be PVC or ABS material. All conductors to be stubbed 24 inches outside of building foundation. All unused conduits to be capped and their location marked.
6. Conduit elbows to be 24 inches radius.
7. Install a thermostatically controlled exhaust fan (minimum 22 C.F.M.). This is required even if an air conditioner is installed.
8. Ground bar is mounted with 1-inch stand-offs and has 8 total 1/4-inch diameter holes.
9. All underground conduits to be provided by customer.