

Section G1: METERING REQUIREMENTS FOR TRANSMISSION GENERATION ENTITIES

PURPOSE:

This section specifies the metering requirements for Generating Entities interconnecting to PG&E's Transmission Power System.

APPLICABILITY

All wholesale generators (Participating Generators who sell power to the market), connected to the transmission system, must meet both PG&E and ISO metering requirements. PG&E metering is required for standby service. All other generators (not providing wholesale service) must meet PG&E's metering requirements. Furthermore, all Generators 1 MW and above must meet all applicable WECC (Western Electricity Coordinating Council) metering standards.

Load entities that install generator(s) to off-set all or part of their load are also subject to telemetering requirements of the generator(s). CPUC [Rule 21](#) typically applies to such installations.

G1.1. BASIC METERING REQUIREMENTS FOR GENERATORS

Metering location: PG&E and CAISO standard metering is required on the high-voltage side of the transformer for all Generating Entities. Exceptions may be granted if it can be demonstrated that high-side metering will create significant safety issues or impose extraordinary costs not typically associated with such metering. CAISO Metered Entities that have installed low side metering shall supply the Transformer Loss Correction (TLC) as specified in CAISO's Metering Protocol Section. If it is not possible to install metering at the delivery point, the readings of the meter(s) shall be adjusted to correct for transformation and line losses. A two (2) percent adjustment factor for each stage of transformation shall be applied to the meter readings for bundled (full-service) PG&E customers.

Metering equipment: Metered sites served at 60 KV and above, require structures mounted for combination metering units. In addition, a meter enclosure in accordance with Engineering Standard 063436, in [Appendix D](#) is required. Note: The metering enclosure shall be a walk in type enclosure and sized adequately to meet all applicable codes and standards. If the Interconnecting Customer wishes to include additional equipment such as line protective relays, telecommunication and/or EMS/SCADA equipment, the size must be adjusted accordingly.

Foundation, structure and disconnect switches for mounting and disconnecting revenue-metering transformers. The support structure shall be a H-frame structure. High-side revenue-metering shall have a minimum of two gang-operated, lockable disconnect devices to facilitate establishing a visual open on each primary side of the metering units. Refer to Engineering Standard 063436 in Appendix D for more information.

The meter enclosure shall be owned and maintained by the generating entity or Transmission Entity. The distance between the meter enclosure and the revenue-metering transformers must not exceed 50 feet to maintain the required metering accuracy. PG&E must approve any variance from this general rule. The enclosure must be a walk-in type enclosure located within and grounded to the substation ground grid. Access to the enclosure must be arranged so that PG&E personnel can read and test the meters without entering the substation yard. The enclosure must be equipped with an auxiliary 120-volt ac duplex plug, an overhead light, a light switch adjacent to the door, and a ground bus connected to the ground and mounted near the bottom of the wall where the meters are to be located.

Meter panels specified by PG&E. Refer to the [Greenbook](#) or Engineering Standard 063436 in [Appendix D](#).

All required conduits and junction boxes. A pull line must be installed in the conduit between the metering enclosure and the junction box at the base of the metering unit support structure to facilitate PG&E installing the metering unit secondary wires. Only PG&E's revenue metering wire shall be installed in the conduit between the metering enclosure and the CT/PT units. Conduits may be metallic or non-metallic. A dedicated land line into the metering enclosure is required for the revenue meter. Where land line is not available, and cellular cell signals are acceptable, the use of cellular phone is acceptable. If the meter phone line cannot be dedicated to the meter, the generating entity shall obtain prior approval from PG&E's local metering group to arrange for a line shared switch to be used with the meter being the secondary phone user. Refer to Engineering Standard 063436, in [Appendix D](#) of this handbook.

Metering Disconnects: This section applies to non-wholesale customers. High-side metering installations shall have a minimum of two gang-operated, lockable disconnect devices at the primary to facilitate establishing a visual open. Disconnect devices are necessary at the following locations:

The first disconnect switch shall be installed at or near the point of interconnection with PG&E (this switch is PG&E-operated)

The second disconnect switch shall be installed between the load side of PG&E's metering and the Generation Entity's electrical facility (this switch is Generation Entity owned and operated). With PG&E's approval, circuit switches with blades can double as the visual open disconnect between the metering transformers and the main transformer. If the Generating Entity deviates from this present design configuration PG&E approval is required prior to Generating Entity's initial submission of related drawings or prints.

If the Generator is a Qualifying Facility (QF) selling power to PG&E on a surplus sale basis, a separate disconnect device (generator or host-site owned and operated) is required on the metered side of the load. Refer to [Figure G1-1](#), located near the end of this section, for typical interconnections.

G1.2. DETAILED METERING REQUIREMENTS FOR GENERATORS

The following sections describe the detailed requirements for metering electricity supplied by generators connected to or operating in parallel with the PG&E Transmission System.

G1.2.2. Metering Configurations For New Generators

Metering configurations for the delivery of power into the PG&E Transmission System fall under the following two general classifications:

Wholesale Generators: Wholesale generators that participate in the CAISO market must execute CAISO's Participating Generating Agreement and meter their power deliveries in accordance with [CAISO Tariff](#). Metering installations must comply with the Meter Certification Requirements and Standards set forth in the [CAISO Tariff](#) and Protocols. Meters for Participating Generators are required at the point of interconnection ([Figure G1-2](#)).

Retail Generators: Power delivered to the generator entity is metered at or near the point of interconnection.

G1.2.3. Metering Requirements For New Generators

The Generation Entity (either retail or wholesale) shall provide, install, own and maintain all mounting structures, conduits, meter sockets, meter socket enclosures, metering transformer cabinets and switchboard service sections of the size and type approved by PG&E and/or ISO. The Generation Entity may have the option to provide, own and maintain metering transformers, as specified by PG&E, rated at more than 600 volts when located within the Generation Entity's substation and used for high-side metering, except when pole-top or metal-clad enclosure metering is used. In addition, wholesale generators are responsible for securing combination revenue metering PT/CT's. Consult with PG&E Meter Engineering for information on combination revenue-metering voltage and current transformers.

The Generation Entity must provide, install, own and maintain all facilities necessary to accommodate PG&E metering or an entity-owned metering which meets PG&E's metering requirements. PG&E must receive and approve meter-location and enclosure dimensional drawings prior to installation of metering equipment. Other requirements vary, depending on the amount of power delivered to PG&E. The distance between the meter and the revenue-metering transformers must not exceed 50 feet to maintain the required metering accuracy. PG&E must approve any variance from this general rule.

G1.2.3.1. Wholesale Generators

Installation of meters: Generation Entities directly connected to CAISO Controlled Grid are responsible for installing, operating, and maintaining CAISO delivery meters in accordance with applicable CAISO

requirements. Generation Entities connected to CAISO Controlled Grid are required to provide PG&E access to the Generation Entity's meter.

G1.2.3.2. Metering Generator's Loads

Metering Generator Loads: When a Generation Entity delivers power to the PG&E Power System, electric service to the auxiliary load associated with the generator plant is also needed. Because deliveries to and from the plant must be separately recorded and treated as separate transactions under PG&E's tariffs, additional revenue-metering will be required in most cases. All meters shall be equipped to prevent reverse registration. In addition, when a generator enters into a service agreement with PG&E for stand-by service, the Generation Entity shall allow PG&E to tap onto CAISO metering circuit with the installation cost to be borne by the end-user (Generation Entity).

G1.3. Telemetry Requirements FOR GENERATOR MONITORING

G1.3.1. For New Generation Facilities 1,000 kW or Greater

For Generating Facilities 1,000 kW or greater, real-time data must be telemetered to PG&E's Control Centers as specified in Appendix F and CAISO, for each generating unit.

G1.3.2. For New Generation Facilities Less Than 1,000 kW

On a case-by-case basis, PG&E may require telemetry for generators of less than 1,000 kW.

G1.4. METERING CURRENT AND VOLTAGE TRANSFORMERS FOR GENERATORS

The customer will provide, install, test, own and maintain metering transformers when they are within the Generator's substation, provided the metering transformers are approved by PG&E before installation and meet the following PG&E specifications:

- CTs and PTs cannot have a bypass switch.
- CTs cannot be switched or fused.
- Metering class PT/CTs (including Dual Winding devices) shall not be used for relaying purposes in the PG&E system. In particular, combination PT/CTs which are installed by PG&E or an approved meter installed by a qualified meter service provider shall not be connected to Generator's protective relays or used to provide protection of Generator-owned equipment or devices. See G2.8.3.
- Metering transformers shall be tested by the manufacturer prior to pre-parallel inspection, and a certified transformer test report shall be provided to PG&E prior to installation. After installation, metering transformers shall be tested by the customer

and a certified transformer test report shall be provided to PG&E. Periodic testing may be required for metering CTs or PTs.

Figure G1-1
TYPICAL INTERCONNECTION
Protection and Metering Installation for Surplus Sale

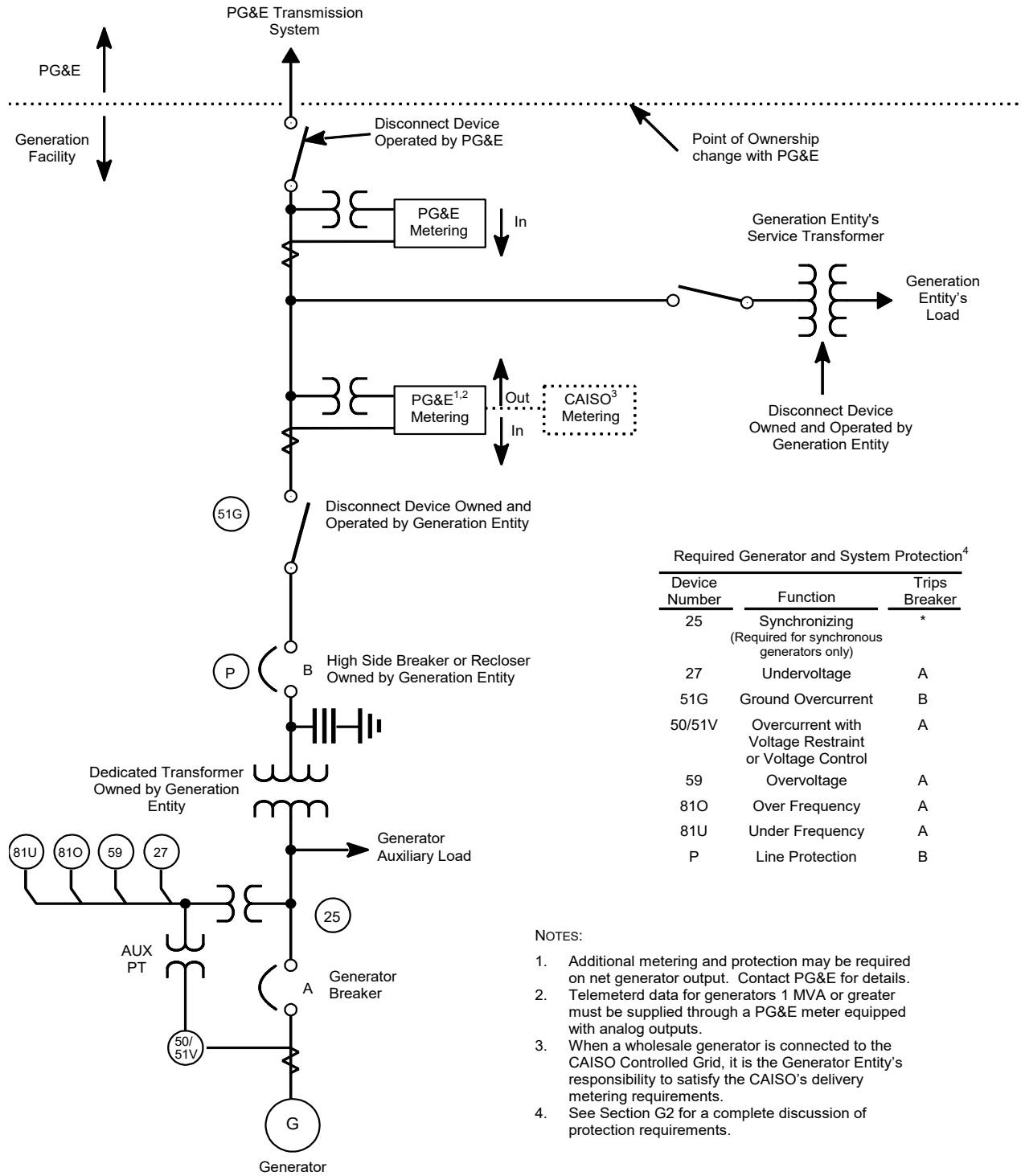

Required Generator and System Protection⁴

Device Number	Function	Trips Breaker
25	Synchronizing (Required for synchronous generators only)	*
27	Undervoltage	A
51G	Ground Overcurrent	B
50/51V	Overcurrent with Voltage Restraint or Voltage Control	A
59	Overvoltage	A
81O	Over Frequency	A
81U	Under Frequency	A
P	Line Protection	B

- NOTES:
1. Additional metering and protection may be required on net generator output. Contact PG&E for details.
 2. Telemetered data for generators 1 MVA or greater must be supplied through a PG&E meter equipped with analog outputs.
 3. When a wholesale generator is connected to the CAISO Controlled Grid, it is the Generator Entity's responsibility to satisfy the CAISO's delivery metering requirements.
 4. See Section G2 for a complete discussion of protection requirements.

Figure G1-2

TYPICAL INTERCONNECTION

Protection and Metering Installation for Net Sale and Wholesale Transactions

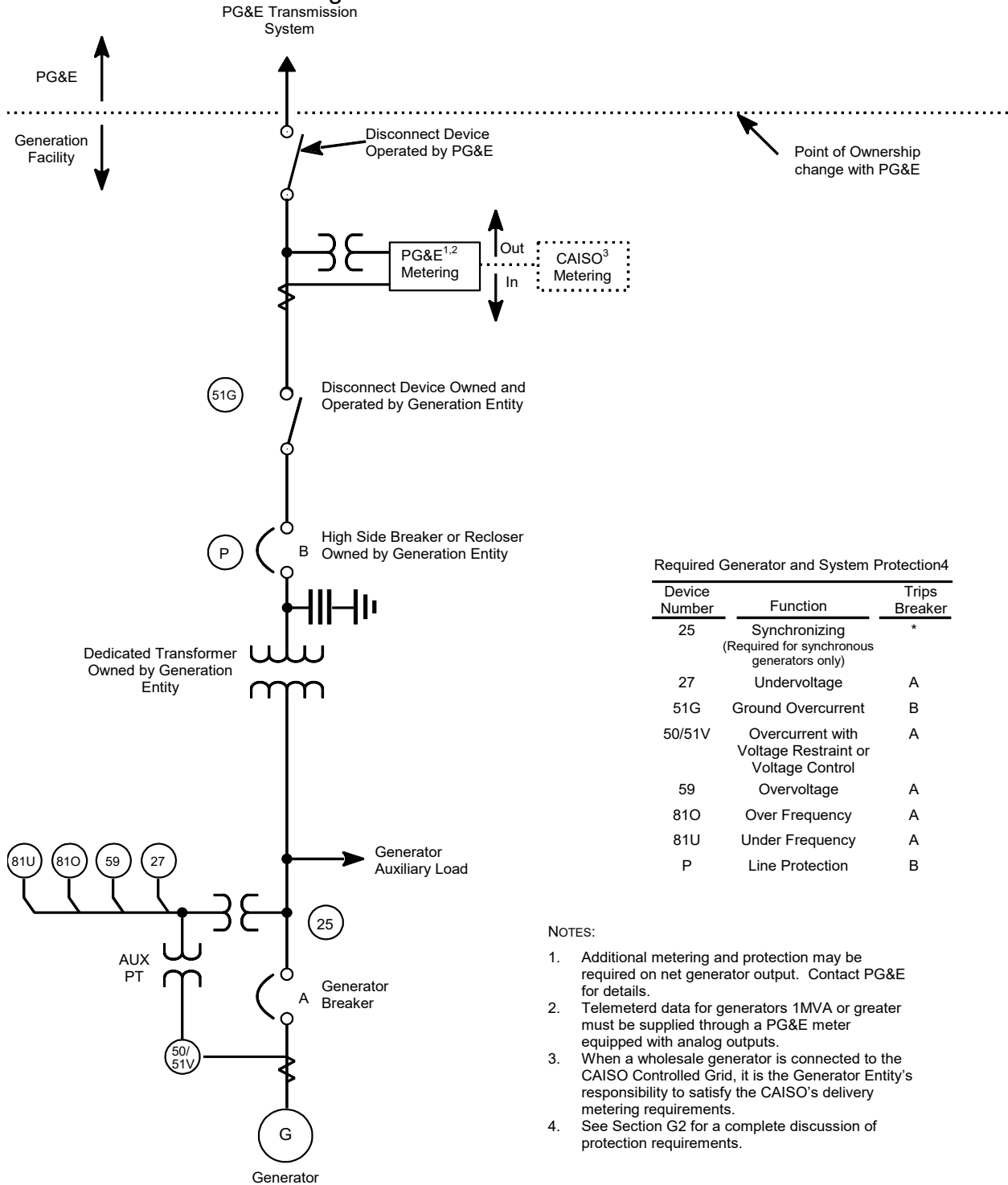

Required Generator and System Protection⁴

Device Number	Function	Trips Breaker
25	Synchronizing (Required for synchronous generators only)	*
27	Undervoltage	A
51G	Ground Overcurrent	B
50/51V	Overcurrent with Voltage Restraint or Voltage Control	A
59	Overvoltage	A
81O	Over Frequency	A
81U	Under Frequency	A
P	Line Protection	B

NOTES:

1. Additional metering and protection may be required on net generator output. Contact PG&E for details.
2. Telemetered data for generators 1MVA or greater must be supplied through a PG&E meter equipped with analog outputs.
3. When a wholesale generator is connected to the CAISO Controlled Grid, it is the Generator Entity's responsibility to satisfy the CAISO's delivery metering requirements.
4. See Section G2 for a complete discussion of protection requirements.