

Appendix F: TELEMETERING AND TRANSFER TRIP FOR TRANSMISSION GENERATION ENTITIES

Table of Contents

APPENDIX F: TELEMETERING AND TRANSFER TRIP FOR TRANSMISSION GENERATION ENTITIES	1
F.0. NOTIFICATION	2
F.1. APPLICATIONS.....	3
F.2. GENERAL REQUIREMENTS.....	3
<i>F2.1. EMS/SCADA Telemetry</i>	4
<i>F2.2. Protection</i>	9
<i>F2.3. Business Telephone and Revenue Metering</i>	13
<i>F2.4. Environmental Considerations</i>	13
F.3. INSTALLATION OF LEC ENTRANCE CABLE IN SUBSTATIONS (RISK - SEE SECTION F.0. NOTIFICATION).....	14
F.4. CIRCUIT REQUIREMENTS FOR PROTECTIVE RELAYING AND EMS/SCADA CIRCUITS INSTALLED BETWEEN GENERATION ENTITY FACILITY STATIONS AND PG&E POWER SUBSTATIONS (RISK - SEE SECTION F.0. NOTIFICATION)	15
F.5. ADDITIONAL DIRECT TRANSFER TRIP (DTT) TELECOMMUNICATION OPTIONS	17
<i>F.5.1. Option 1. All Fiber</i>	17
<i>F.5.2. Option 2. Fiber / Channelized T1 using fiber based HVP protection</i>	18
<i>F5.3. Option 3 - Copper / Channelized T1 using copper HVP</i>	19
F.6. DEFINITIONS	20
F.7. FIGURES.....	22

F.0. Notification

PG&E has been notified by two Local Exchange Carriers (LECs) in its territory as follows:

- The LECs are planning to discontinue DS0 (a basic channel rate in the telecommunications transmission hierarchy corresponding to the capacity of one voice-frequency-equivalent channel) or sub T1 rate Leased Telecommunications circuits in the future.
- There will be a sunset on maintenance of DS0 and copper infrastructure in the field.

This notification has major implications to PG&E and the Generation or Load Entity in regard to available telecommunications options in the near future. For years, PG&E has been using standard communications equipment for SCADA, EMS, and teleprotection that interfaces with DS0 voice grade channels. This notification implies that current telecommunications DS0 4-Wire lease options will not be available in the future and there is substantial risk that any DS0 circuits will not be maintained. The lack of maintenance on these services would render these circuits as unacceptable to meet Transmission Interconnection requirements.

To address the discontinued DS0 leases, excessive interconnection delays and the high cost of Local Exchange Carriers (LECs) providing traditional metallic Class A communication circuits, PG&E has approved additional Direct Transfer Trip (DTT) Telecommunication Options (see [Section F5.0](#) of this appendix). These options provide LEC services via point-to-point channelized T1 Lease services (T1 High Cap - B8ZS/ESF) and will require a channel bank at the Generation Entity premises and Digital Cross-connect System (DCS) equipment at PG&E's premises to facilitate end-use DS0 channels. PG&E recommends using PG&E standard channel bank for compatibility and reduced troubleshooting time. The channel bank (will facilitate using existing standard SCADA, EMS, and teleprotection DS0 equipment interfaces and multiplex them to the T1 circuit. These options will provide the necessary reliability to PG&E's system yet may increase the risk of 3rd party generation trips from using IEEE-487 Service Performance Objective Class B, T1 Lease communication circuits.

For SCADA and EMS applications, PG&E has added additional options to use for Electric SCADA and EMS

- ATT Managed Router Services
 - AVPN (ATT-Virtual Private Network)- Wireline Fiber
 - ATT (ATT First Net Cellular)

Monthly fees services will be the responsibility of the customer and will vary depending on the data usage and availability with the service applied.

F.1. APPLICATIONS

Before a new Generation Entity facility may be connected to the PG&E Power System, PG&E will specify the protection and telecommunications systems that will be required. These protection and telecommunications systems must be operational and satisfactorily commission-tested before parallel operation may begin. Due to the highly specialized and critical nature of transfer trip equipment, PG&E recommends that all such equipment be owned, installed and maintained as Special Facilities by PG&E, at the generating entity's expense.

F.2. GENERAL REQUIREMENTS

The Generation Entity is responsible for acquiring or providing the communication medium (lines) for transmission of transfer trip signals, alarms/status points, and the telemetry data. Typical requirements are shown in Figure F-1. PG&E should be contacted to determine applicable telecommunications transmission media.

Although PG&E may discuss telecommunication options with the Generation Entity, PG&E has the sole right of selecting the final approved telecommunications plan. This plan must fit within PG&E's communications architecture, design parameters, and operational requirements of PG&E's existing telecommunications network.

Due to the Notification in Section F.0, PG&E is currently reviewing options for telecommunications. Once these options are vetted and tested, PG&E will look for opportunities to include them as options to meet Generation Interconnection requirements.

Current options for telecommunications are included in this section, they include:

- EMS/SCADA Telemetry PG&E's Grid Control Center Node and the Designated PG&E Electric Control Center
 - Direct Fiber to PG&E Substation with proper interface provisioning
 - Licensed Microwave with proper Interface provisioning
 - DS0 4-Wire Lease Line provisions by Local Exchange Carrier (LEC) (Risk - see [Section F.0](#). Notification)
 - additional Telecommunication Options via the new Class B, T1 Lease Options (see [Section F5.0](#) of this appendix)
 - For SCADA and EMS applications, PG&E has added additional options to use for Electric SCADA
 - ATT Managed Router Services
 - AVPN (ATT-Virtual Private Network)-Wireline Fine
 - ATT (ATT first Net Cellular)

These options are provided only under certain conditions and must have an acceptable cellular carrier (Data) signal on the associated PG&E Standard Cellular Carrier APN. See Section F2.1. **Note:** for locations with EMS/SCADA only

- Electric System Protection Direct Transfer Trip
 - Direct Fiber to PG&E Substation with proper interface provisioning
 - Licensed Microwave with proper interface provisioning
 - Class A DS0 4-Wire Lease Line provisions by Local Exchange Carrier (LEC) (Risk - see [Section F.0.](#) Notification)
 - additional Direct Transfer Trip (DTT) Telecommunication Options via the new Class B, T1 Lease Options (see [Section F5.0](#) of this appendix)

PG&E has benchmarked with other Utilities in the WECC service territory, many are requiring the direct Fiber Option for Electric System Protection and do not consider LEC lease service as an option. The industry is moving toward standard use of Fiber for Electric System Protection services.

The types of circuits which may be required between the Generation Entity facility and PG&E's facilities fall into the following categories:

F2.1. EMS/SCADA Telemetry

Telemetry signals must be transmitted via circuits between the Generation Entity facility and PG&E Grid Control Center (GCC) Jurisdictions where PG&E EMS/SCADA systems reside (as specified in Section G-1 of this handbook). A typical telemetry installation is shown in [Figure F-1](#).

A SCADA telemetry circuit, required to monitor the transfer trip protection circuit(s), is intended to ensure equipment operability and the continuity of the circuit. SCADA and EMS equipment uses standard analog and digital DS0 interfaces. Due to the LEC discontinuing DS0 service, a channel bank will be required to interface the SCADA and EMS equipment to a T1 (T1 High Cap - B8ZS/ESF) lease. Alarms (See F.2.1) must be transmitted to the designated PG&E GCC using a circuit at the Generation Entity's expense. Any maintenance support labor costs, incurred by PG&E personnel to assist in the restoration of the Generation Entity's circuits (both EMS/SCADA and protection circuits) will be billed to the Generation Entity for reimbursement. Repair times for EMS/SCADA communications circuits are referenced in TIH Section G2, Table G2-2.

For Generating Facilities 1,000 kW or greater, real-time data must be telemetered to PG&E's Control Center EMS for each generating unit. See F.2.1.2 below.

Note - For facilities with SCADA/EMS telemetry data only with no DTT,

- ATT Managed Router Services:
 - AVPN (ATT-Virtual Private Network)-Wireline Fiber
 - ATT (ATT First Net Cellular)

If the generation is 100MW or more, the Generation Entity will be required to provide a second or alternate EMS circuit to the Designated Electric Control

Center. On a case by case basis, PG&E may approve the Generation Entity to provide a circuit to the nearest PG&E EMS data node facility. PG&E would then route the alternate data on its infrastructure to PG&E's Electric Grid Operations (GCC and Rocklin).

Telemetry equipment (a multi-ported RTU for EMS and SCADA) shall be located in the telecommunications equipment room. At the Generation Entity's expense, PG&E may supply telemetry equipment at the Generation Entity's site and PG&E's Grid Control Centers. The Generation Entity is responsible for providing and maintaining all telecommunication circuits.

In some cases, the LEC may install amplifiers or line treatment equipment. This equipment is operated by 110V AC power. It is recommended that an uninterruptible power supply (UPS) be provided and powered by a station DC battery. CPUC tariffs may prevent the local LEC from using a Generation Entity provided DC power for its termination equipment.

F2.1.1. SCADA Telemetry for all Generation Entities with Transfer Trip Protection

For all Generation Entity facilities with Transfer Trip (TT) for protection circuits, a minimum number of alarms are required to be transmitted to PG&E. They include, but are not limited to, the following:

- Breaker trip,
- Transfer Trip receive,
- Channel Failure
- Hardware Failure
- Breaker Status
- Cut-Out position
- Local/Remote Switch position
- Remote station Alarm
- DC Undervoltage Alarm

F2.1.2. Energy Management System (EMS)/SCADA Telemetry for Transmission Generation Entity Facilities 1,000 kW or Greater

For Transmission Generating Entity facilities 1,000 kW or greater, the following real-time data must, at a minimum, be telemetered to PG&E's Control Centers Energy Management System (EMS) for each generating unit based on interconnection type and source. PG&E is also required to transmit telemetry data to CAISO as required by CPUC directives.

Telemetry required for resources following the CAISO tariff and Rule 21 tariff are as follows: (The numbers correspond to the numbers shown in Figures 2.1-A, 2.1-B, and 2.1-C)

- 1 – Point of Delivery (POD) to PG&E System¹ [MW, MVar, kV, breaker status]
- 2 – Generating Unit Net MW, MVar
- 3 – Switchyard Bus Voltage [kV]
- 4 -- Auxiliary Load [MW, MVar]
- 5 – High side of Transformer(s) [MW, MVar, KV]¹
- 6 -- Capacitor bank circuit breaker status (if switched capacitors are installed)

¹ Transformer refers to the main transformer connected to PG&E Transmission Voltage. In some cases, this is the same location as the Point of Delivery

Synchronous (Figure 2.1-A):

- 7 - Unit Gross [MW, MVar]
- 8 - Unit Generator Breaker status
- 9 - Generating Unit Terminal Voltage [kV]
- 10 - Automatic Voltage Regulator (AVR) status
- 11 - Power System Stabilizer (PSS) status (if PSS installed per G3.1.1.3)

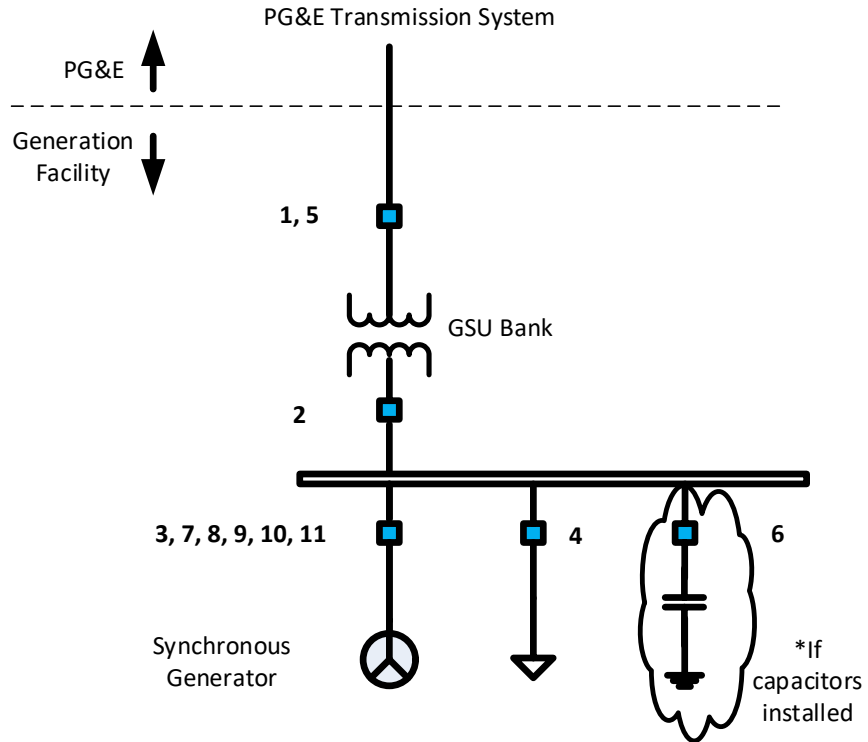

Figure 2.1-A - Example Synchronous Generator Telemeter Points

Non-Synchronous (Figure 2.1-B):

12 - Aggregate MW at collector bus [MW, MVar]

13 - Instantaneous State of Charge (MWh) (for battery projects)

14 - Maximum Continuous Energy limit (MWh) (for battery projects)

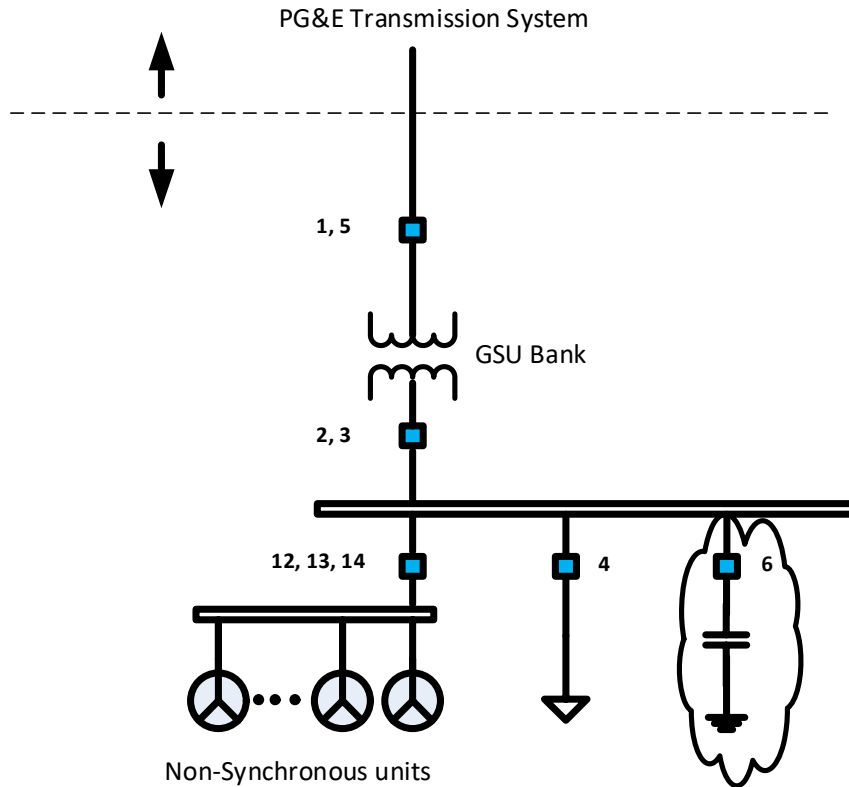

Figure 2.1-B - Example Non-Synchronous Generator Telemeter Points

Rule 21 Interconnections on Transmission (Figure 2.1-C):

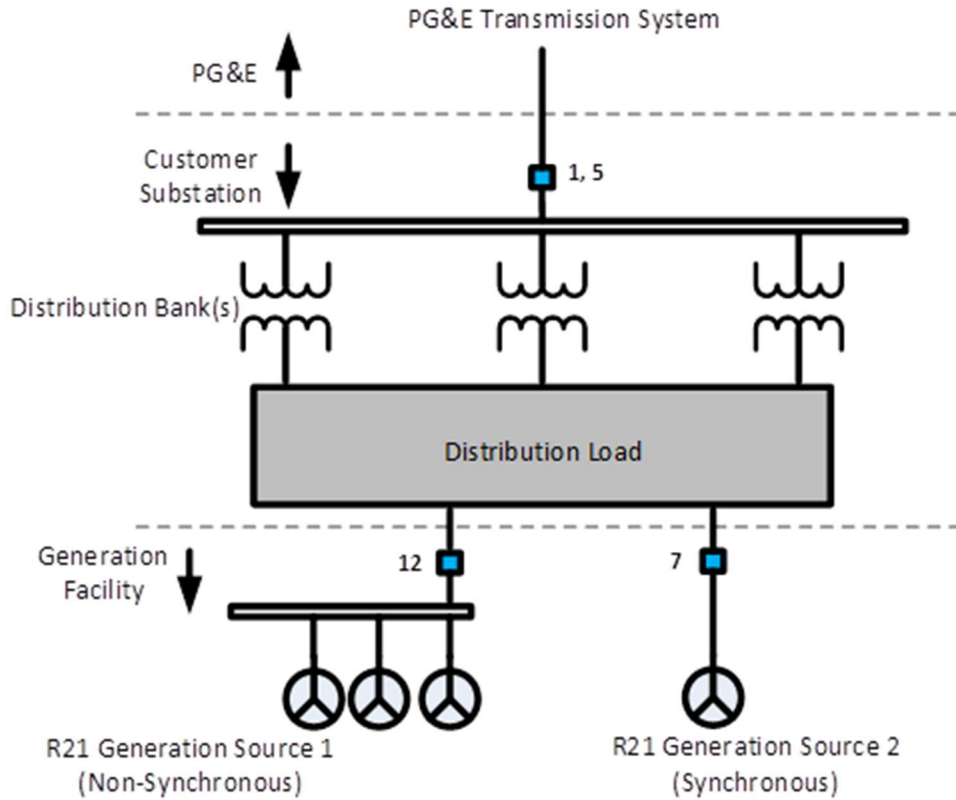

Figure 2.1-C - Example Rule 21 Generator Telemeter Points

F2.2. Protection

PG&E System Protection will determine if non-pilot (non-communication aided) protective relays will be adequate for emergency tripping of the Generation Entity facility and PG&E’s station equipment, or if additional systems such as teleprotection assisted transfer trip, current differential, phase comparison or some other type of communication aided protection system along with the type protection equipment and systems are needed². For all Protection schemes, PG&E System Protection will determine and approve the protection necessary for the Generation Entity interconnection.

² Any communication-assisted protective system must be end-to-end satellite tested (as a system) prior to release for commercial operation and as determined necessary by PG&E for the life cycle of the generation project. End-to-end tests and overall system tests are performed after satisfactory testing of individual devices, components, and trip and control circuits at each of the interconnected terminals prior to initial release for operation. However, there are occasions when PG&E will require the end-to-end tests to be repeated after the original tests are completed.

Where remote tripping is involved (i.e. DTT, SPS/RAS) then follow the guidance provided by WECC as described in “Communications Systems Performance Guide for Electric Protection Systems”, dated July 25, 2013.

The following table summarizes the maximum End-to-End time delay and minimum availability by PG&E voltage level.

PG&E BES Voltage	Maximum End-to-End Time Delay (2)	Minimum Availability (2)
500 kV	< 25 msec	99.93%
230 kV	< 33 msec	99.88%
< 115 kV	< 67 msec	99.48%
Non-BES lines, Medium Voltage and Low Voltage applications that provide grid support (3)	<67 msec	94.98%

Notes:

- (1) This table is a condensed version of Table 2 in “Communications Systems Performance Guide for Electric Protection Systems”, dated July 25, 2013.
- (2) These values are for the total protection system which is the sum of the communication component and the relaying component.
- (3) An example is where a large 115 kV interconnection system, that has DTT that goes from a MV breaker to a LV inverter.

The Generation Entity, or its representative, is responsible for specifying the style to meet proper DC voltage, desired mounting configuration, and other substation pertinent hardware specifics. The Generation Entity is also responsible for coordinating and performing complete functional testing of the protective scheme including the end-to-end tests. End-to-end testing is associated with testing of the relay and associated communication circuits between all terminals (protecting an interconnected line) as a system. Should PG&E be required to assist in future maintenance, the Generation Entity will arrange for design and installation of the equipment with necessary isolation and test switches in conformance to the PG&E standards. Common communication assisted protection schemes are noted below:

- **Current differential and phase comparison.** Current differentials or phase comparison line relays may be required for line protection³. The relay may be applied using direct Fiber or Licensed Microwave circuits.
- **Direct Transfer Trip.** A direct transfer trip (DTT) system is the typical type of system installed for high-speed tripping of the Generation Entity facility's station equipment. When a line fault occurs, the DTT equipment provides faster fault clearing and helps to isolate and protect the Generation Entity facility from damage and maximize public safety. In many cases DTT is the only method for removing the generator from a faulted system. DTT equipment uses standard DS0 interfaces, using either analog or digital trip transmission methods. Due to the LEC discontinuing DS0 service, a channel bank will be required to interface the DTT equipment to a T1 (T1 High Cap - B8ZS/ESF) lease. Elementary diagrams for the typical relay circuit configurations at the Generation Entity facility, with auto reset and lockout relay schemes, are provided in [Figure F-2](#). Options for Electric System Protection Direct Transfer Trip include:
 - Direct Fiber to PG&E Substation with Interface provisioning
 - Licensed Microwave with DS0 provisioning
 - Class A DS0 4-Wire Lease Line provisions by Local Exchange Carrier (LEC) (Risk - see section F.0. Notification)
 - additional Direct Transfer Trip (DTT) Telecommunication Options via the new Class B, T1 Lease Options (see [Section F5.0](#) of this appendix)
 - Power Line Carrier
- **Fiber Optics Cable (FOC).** PG&E recommends the Generation Entity facility provide Fiber to meet with all PG&E Standards for Fiber Cable Installation. If the Fiber is part of the Special Facilities Agreement (SFA) and/or located on PG&E owned Transmission Towers or Right-of-Ways, the Fiber cable must meet PG&E's Standards. These standards can be provided to the Generation Entity facility after agreements have been executed between PG&E and the Generation Entity facility. In the case of fiber optics cable, special consideration should be given to routing. It is recommended not to incorporate it as part of the same transmission line that carries the Generation Entity facility's power. Special entrance cable specifications for this application are the same as those discussed in the next section.
- The following considerations shall be applied where fiber optics cable is used for protection⁴:
 - PG&E will determine whether one level of high-speed pilot protection is sufficient or redundant pilot protection is required for interconnection.

³ Refer to Table G2-1a.

⁴ Refer to Appendix S and Section G-2 for additional information and regional reliability requirements.

- If PG&E determines that one level of pilot protection is sufficient for the interconnection, then the communication path may be carried on the transmission line.
- Should two levels of pilot protection be required by PG&E, the communication medium route for one level of transmission line protection may be the same as the transmission line that carries the Generation Entity facility's power; however, the other communication circuit must be on a separate path not prone to common mode failure.
- Based on the types and the levels of protection and the required communications mediums, PG&E will determine whether independent channel or equipment are required for direct transfer trip.
- PG&E recommends that the ordering information for current differential phase comparison type relays and all high-speed protection schemes between all the terminals of a transmission line be coordinated, particularly when the equipment for the remote terminal is procured by the Generating Facility or its representative.
- **Licensed Microwave.** Licensed Microwave may be possible for certain Interconnection Projects. A Licensed Microwave option will be estimated after agreements have been executed with the Generation Entity facility. Use of Microwave as an option and the selection of Microwave equipment vendor and product will be at PG&E's sole discretion.
- **Power Line Carrier.** Power line carrier protection may be possible in certain interconnection projects. This type of teleprotection is usually associated with distance-based relay systems⁵. The Generating Facility is responsible for scheduled (route) maintenance of the carrier associated equipment including tuning of the wave trap and associated coupling devices, as necessary⁶.
 - Leased Local Exchange Carrier Services for DTT. Leased services include: legacy DS0 leases both analog 4-Wire and digital services. These services are no longer offered by the Local Exchange Carriers, See Section F.0.

Protection circuits must be highly reliable; thus, the following requirements must be met (exception: these requirements may not be possible when using the new Class B, T1 Lease additional Direct Transfer Trip (DTT) Telecommunication Options (see [Section F5.0](#)). When using these Class B lease options, the Generator Facility must request the option to use in Section F5.0 and sign an agreement with PG&E to accept the conditions for separation of its' generators from PG&E's system. This may include automatic tripping (separation) due to a communications failure as stated in the Operating Procedures Section G4.4.2):

⁵ The application must meet IEEE and PG&E recommended X/R ratios.

⁶ Signal Amplifiers may also be required for proper transmission of signals.

- **Uninterruptible Power Source.** In order to ensure operation of the Transfer Trip (TT) circuit even during a fault situation, the TT transmitting and receiving equipment must be supplied with DC battery power from a separate circuit breaker. For a 125 Volt DC station, the DC source shall be equipped with a dedicated 15 amperes circuit breaker⁷. The station battery voltage must be decided upon before the TT equipment can be ordered.
- **Class A Service Objective.** (Risk - see [Section F.0](#). Notification) A leased circuit must meet the Class “A” Service Objective (circuit will work before, during and after the fault). This also means that carbon block, gas tube, and/or solid state protectors that arc or short the Tip and Ring to ground for voltages of 300-350 volts will not be able to be used in the circuit. The LEC must use Mutual Drainage Reactors (MDRs) at their Central Office (CO) or Remote Terminal (Remote CO).
- A lease service for Protection circuits such as DTT requires the use of a line termination unit, which is a passive data interface and has no loop-back capabilities. By requiring a passive service⁸, the LEC will provide the line amplifiers at their central office.

F2.3. Business Telephone and Revenue Metering

A business telephone is required at the locations of DTT, telemetering, alarm, and metering equipment, so that maintenance and repair work can be performed efficiently. The phone service must remain for the life of the project or be replaced with a PG&E approved system. Due to Local Exchange Carriers (LECs) phasing out DS0/copper services, upon request PG&E may evaluate other options such as cellular service, satellite service, leased microwave, etc. PG&E must approve in writing, alternatives to business phone service.

A dedicated 1MB phone line into the metering enclosure is required for the revenue meter. Where a 1MB is not available, and cellular cell signals are acceptable, the use of cellular phone is acceptable. If the revenue meter phone line cannot be dedicated to the meter, the generating or load entity shall obtain prior approval from PG&E’s local metering group to arrange for a line shared switch to be used with the meter being the secondary phone user. Refer to Engineering Standard 063436, in Appendix D of this handbook.

F2.4. Environmental Considerations.

PG&E must review and approve the Generation Entity’s proposed equipment and room arrangement. See [Figure F-4](#) for the typical room and conduit requirements for a small power plant. A minimum of one 7 1/2 foot 19-inch relay rack will be required for the teleprotection devices ([Section F2.2](#)) and RTU ([Section F2.1](#)) (this does not include the telecommunications transmission

⁷ The Generation Entity, or its representatives, are responsible for determining the proper size of the DC circuit breaker.

⁸ A circuit on which no active devices are placed that require AC power.

equipment (Fiber, MW, PLC, etc.). Deviations from PG&E's requirements must be approved by PG&E.

- **Human Environment.** Personnel cannot be expected to maintain and repair equipment that is located in an outdoor cabinet or in a small building, which would subject the personnel, or their test equipment to extremes in temperature and/or precipitation. In addition, 36 inches of working space must be provided in front and back of equipment that is powered by 0-600 volts. Aisles must be a minimum of 36" wide.
- **Equipment Environment.** Extreme temperatures and/or excessive moisture can increase the deterioration of equipment components and wiring. Premature failure of vital protection and telemetering equipment could result in severe damage to expensive transformer banks and line conductors, as well as the loss of vital data required for efficient operation of PG&E's Transmission Operating Center and the Designated PG&E Electric Control Center. Therefore, the following requirements shall be met:
 - The equipment room shall have an HVAC system to maintain proper environmental controls All telemetering and transfer trip equipment should be installed in environmentally controlled buildings. The HVAC system should maintain a positive air pressure differential with the surrounding areas. Temperature shall be maintained between 10°C to +30° C with a 5-95% non-condensing relative humidity
 - **Maintenance of equipment area.** Typically, environmentally controlled buildings are cleaner and easier to keep clean. It should be noted that any failures of vital equipment at the Generation Entity's premise due to excessive dirt could severely damage station equipment. Labor and material costs for work performed to repair equipment so damaged will be billed to the Generation Entity.

***F.3. INSTALLATION OF LEC ENTRANCE CABLE IN SUBSTATIONS
(Risk - see [Section F.0. Notification](#))***

This section provides a notification as general information regarding the High Voltage Protection (HVP) issues. For proper installation and coordination with the LEC, the Generation Entity facility should refer to IEEE Standard 487, "IEEE Recommended Practice for the Protection of Wire-Line Communication Facilities Serving Electric Supply Locations" and IEEE Standard 1590, "IEEE Recommended Practice for the Electrical Protection of Communications Facilities Serving Electric Supply Locations Using Optical Fiber Systems".

It is extremely important that the proper cable and protection equipment be installed at substations and other high-voltage electric facilities. The main determinant is the highest expected ground potential rise (GPR). The calculated GPR value will determine what grade of telephone cable high-voltage protection equipment is required as well as the minimum dielectric strength of the cable insulating jacket. The information required to determine the GPR is as follows:

- Highest calculated line-to-ground fault current and the X/R value. The responsible party shall provide the information.
- Ground resistance (Generation Entity- provides information, after the station ground grid is installed).

The Generation Entity must also provide the station ground grid area. Based on the grid area and the GPR, the responsible party will determine the estimated distance from the grid, that the sheath of the entrance telephone cable must not be grounded. This is the distance where the GPR is expected to diminish to a magnitude of 300 volts (working limit). The working limit is the voltage at which gas tube protectors can be used (except for Class A service).

The LEC serving the area in which the Generation Entity facility is located should be contacted early (up to six months) so outside plant facilities can be engineered to serve the Generation Entity facility location. Failure to do this could result in the postponement of the Generation Entity facility's operational date and additional cost, if the entrance facility is not installed properly or the wrong materials are used. For example, entrance conduits should be non-metallic. Detailed specifications will be provided by both PG&E and the local LEC.

F.4. CIRCUIT REQUIREMENTS FOR PROTECTIVE RELAYING AND EMS/SCADA CIRCUITS INSTALLED BETWEEN GENERATION ENTITY FACILITY STATIONS AND PG&E POWER SUBSTATIONS (Risk - see [Section F.0. Notification](#))

This section provides a notification as general information regarding the High Voltage Protection (HVP) issues. For proper installation and coordination with the LEC, the Generation Entity facility should refer to IEEE Standard 487, "IEEE Recommended Practice for the Protection of Wire-Line Communication Facilities Serving Electric Supply Locations" and IEEE Standard 1590, "IEEE Recommended Practice for the Electrical Protection of Communications Facilities Serving Electric Supply Locations Using Optical Fiber Systems".

The circuits requested for protective relaying purposes require that the LEC service, including entrance circuits entering the terminal sites via the protective relaying circuit dedicated entrance cable, conform to the protection standards determined by the LEC power and PG&E's responsible engineer. Certain independent telephone companies are not tariffed to provide protection equipment for the required circuits. In such a case, the Generation Entity is responsible for the purchase of the necessary protection equipment. Even if the LEC is tariffed to provide the protection equipment, the Generation Entity may decide to purchase their own high voltage equipment to save on monthly and installation charges. It should be noted that the Generation Entity is responsible for the leased circuits or alternative communication media for circuits. If PG&E personnel are requested to perform work, and it is later determined that the cause of the problem is related to the telephone line, or other Generation Entity-owned equipment, PG&E will bill the Generation Entity for the labor and travel expenses.

PG&E will assist in determining the addresses for the PG&E facilities as well as confirm the circuit ordering specifications. The Generation Entity, when placing the service request, should inform the LEC that the circuit will terminate in a high voltage location and if the circuit will terminate at other high voltage locations. Special high voltage protection requirements should be reviewed by the LEC's protection department. The time required for this type of service is typically a minimum of 3-4 months. Ground potential rise data (ground resistance and ground mat area) is required by the LEC. The responsible party shall provide the maximum fault current value and the X/R value. The Generation Entity must determine if the high voltage protection equipment will be leased or owned.

F.5. Additional Direct Transfer Trip (DTT) Telecommunication Options

To address the discontinued DS0 leases (see Section F.0), the following three new options are allowed, effective July 1, 2012, and are shown here:

F.5.1. Option 1. All Fiber

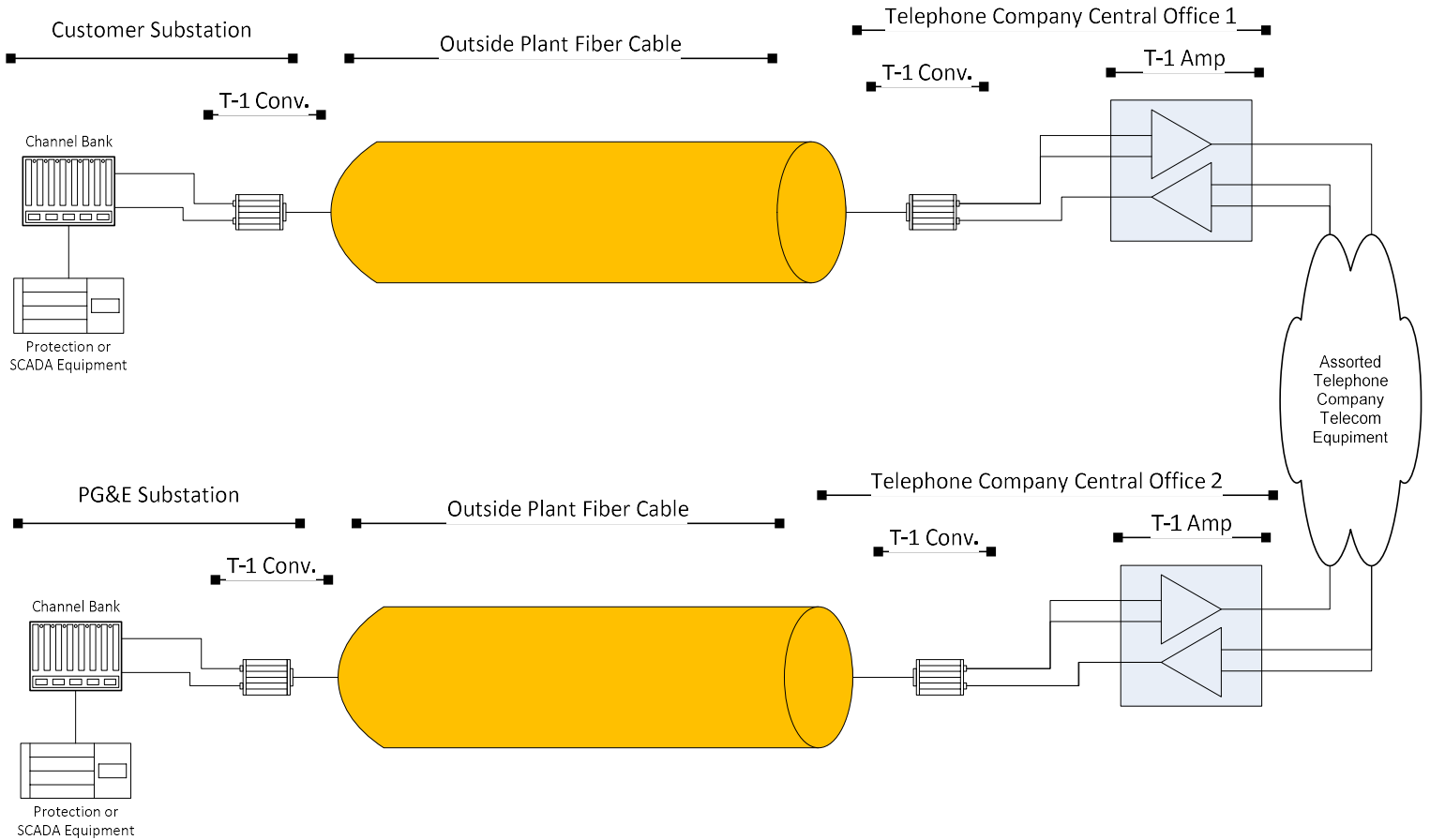

Protection Circuit Over All Fiber Between Substations
 Automatic trip upon loss of signal is not required.
 Manual trip may be required

This solution uses fiber from PG&E’s substation to the telephone company (LEC) facility to the Generation Entity’s substation (no metallic connections). It provides very high speed (multiple T1 speed) and digital circuit with demultiplexing to the T1 level and uses telephone company-provided multiplexing equipment.

One common version of this is a node on SONET ring. This is the preferred solution for protection-related transfer trip. The fiber routing must meet all IEEE Class A circuit requirements and must function prior to, during and after a fault on the line and equipment being protected.

This configuration is the preferred option, since it provides the most reliable means of transmitting a protection trip. This configuration does not require a generator trip upon loss of carrier signal. However, to protect the system during loss of channel, PG&E may request the Generation Entity to disconnect the generator.

F.5.2. Option 2. Fiber / Channelized T1 using fiber based HVP protection

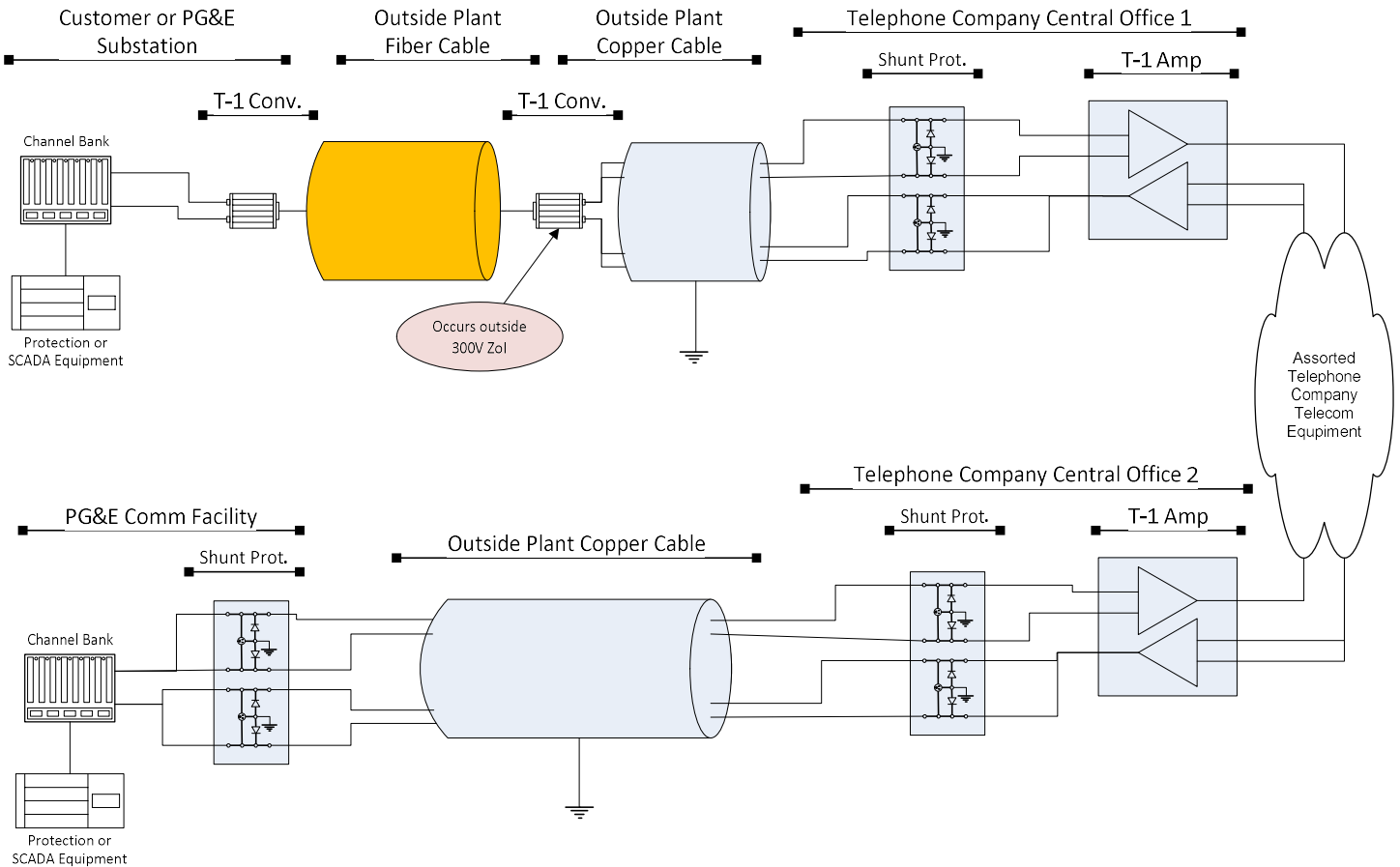

Protection Circuit Over Hybrid/Copper Facilities DTT Receiver programmed to trip the generator off line for a communication fail alarm on the Third Party Provided Telco lease line.

This solution uses conventional, copper T1 from the telephone company (LEC) to the 300V GPR point outside both PG&E's and the Generation Entity's substation. From the 300V GPR point, the circuit is extended using all dielectric fiber optic cable to the substation. This is a commonly used configuration to provide T1 service to cell sites that are co-located on high voltage towers.

All outside plant equipment involved in this solution is to be powered from the telephone company's (LEC's) central office. The Generation Entity must ensure that the final termination at the substation also has reliable, secure, power as well. Any transfer trip circuits delivered via this method (Option 2) may require

carrier fail tripping (330 milliseconds), configured to trip the Generation Entity facility’s breaker when the tripping circuit carrier signal is lost for more than 330 milliseconds. The final decision is subject to review by PG&E Electric System Protection.

The Generation Owner shall agree in writing that they could be subject to nuisance trips (for loss of signal) and not hold PG&E liable for claims of lost generation or other damages. This should be included in a “Service Level Agreement”. However, this solution is a commonly applied solution and should provide better availability and fewer trips for loss of carrier than Option 3.

F5.3. Option 3 - Copper / Channelized T1 using copper HVP

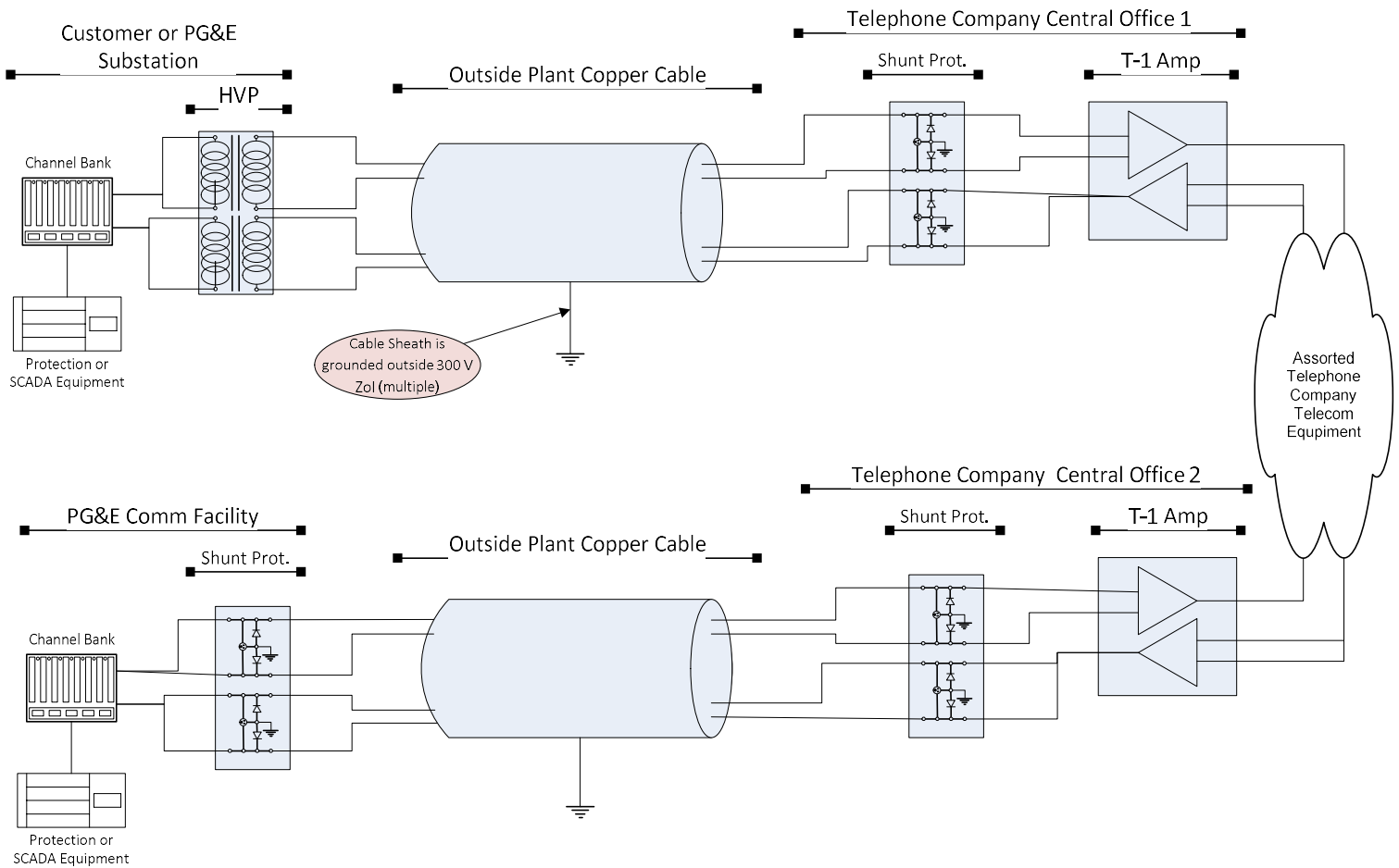

Protection Circuit Over Copper Facilities DTT Receiver programmed to trip the generator off line for a communication fail alarm on the Third Party Provided Telco lease line.

This is an all copper (Class B) transfer trip solution. The Generation Entity will install independent Class B T1 circuits to the Generation Entity’s substation and from each of the PG&E substations (if more than one PG&E substation is involved). Each Class B circuit can trip the Generation Entity independently.

This solution uses traditional T1 metallic delivery in the substation environment (Class B) and any transfer trip circuits delivered via this traditional method (Option 3) MUST be configured to trip the Generation Entity facility's breaker when the carrier signal is lost for more than 330 milliseconds.

The Generation Owner shall agree in writing they could be subject to nuisance trips (for loss of signal) and not hold PG&E liable for claims of lost generation or other damages. This should be included in a "Service Level Agreement".

F.6. Definitions

APN - Cellular Private Access Point Name - provides a private secure IP connection through a cellular carrier's network to PG&E's Secure Operational Network for a remote cellular device.

B8ZS – North American T1 line code, Bipolar with Eight-zero Substitution (B8ZS)

Class A – Non-interruptible service performance (shall function before, during, and after the power fault condition), as defined in IEEE 487-2007.

Class B – Self-restoring interruptible service performance (shall function before and after the power fault condition), as defined in IEEE 487-2007.

Demultiplexing – Separating slower speed circuits out of a higher speed circuit

DS0 - Digital Signal 0 (DS0) is a basic digital signaling rate of 64 kbit/s, corresponding to the capacity of one voice-frequency-equivalent channel. The DS0 rate forms the basis for the digital multiplex transmission hierarchy in telecommunications systems used in North America.

DS1 – Digital Signal 1 (DS1) is a T-carrier signaling scheme with a rate of 1.544 Mbit/s widely used in North America. It is a logical bit pattern used over a physical T1 line. The term is often used interchangeably with T1.

DS3 – Digital Signal 3 (DS3) is a T-carrier signaling scheme with a rate of 44.736 Mbit/s widely used in North America. It is a logical bit pattern used over a physical T3 line. The term is often used interchangeably with T3 (See T3).

DTT – Direct Transfer Trip

EMS – Energy Management System

ESF – Extended Super Frame, is a standard T1 framing standard.

GCC – Grid Control Center

GPR -- A rise in ground potential caused by a substation fault

HVP -- High Voltage Protection circuitry – prevents fault current from a ground potential rise from traveling on telephone cable pair to a remote ground

LEC - Local Exchange Carrier, also referred to as the telephone company

Multiplexing – Combining several slower speed circuits into a higher speed circuit

SCADA – Supervisory Control and Data Acquisition

SONET -- Synchronous Optical Network – one method for multiplexing and demultiplexing electrical signals onto a fiber cable

T1 – A multiplexed electrical signal containing 24 individual DSO channels. The term is often used interchangeably with DS1 (See DS1).

T3 – A multiplexed electrical signal containing 28 individual DS1 channels. The term is often used interchangeably with DS3 (See DS3).

TOC – Transmission Operation Center

F.7. Figures

Figure F-1 High Level 3rd party Generation Entity facility interconnection

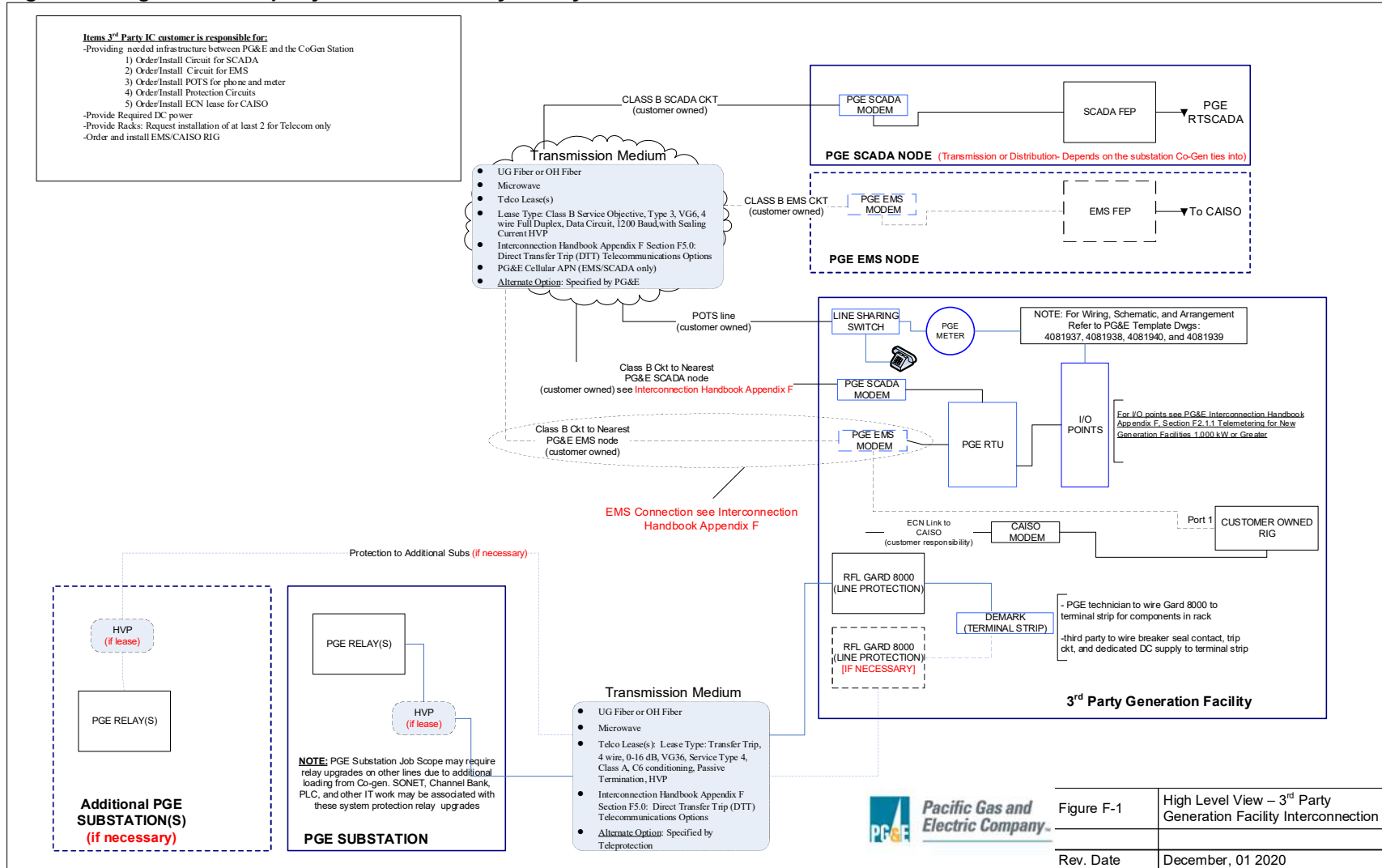

Internal

AF-22

Internal

**NETWORK
CONNECTION
ADDITIONAL OPTIONS**

OPTION A

3rd Party Cogen Owned and Maintained

3rd Party Generator/QF Location
Fiber VPN (AT&T Virtual Private Network – AVPN)

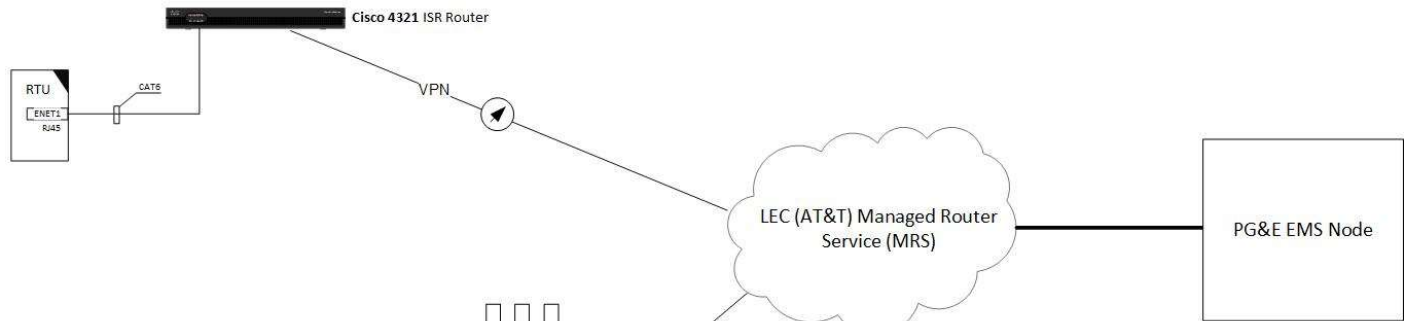

OPTION B

3rd Party Generator/QF Location
- AT&T FirstNet (Cellular)

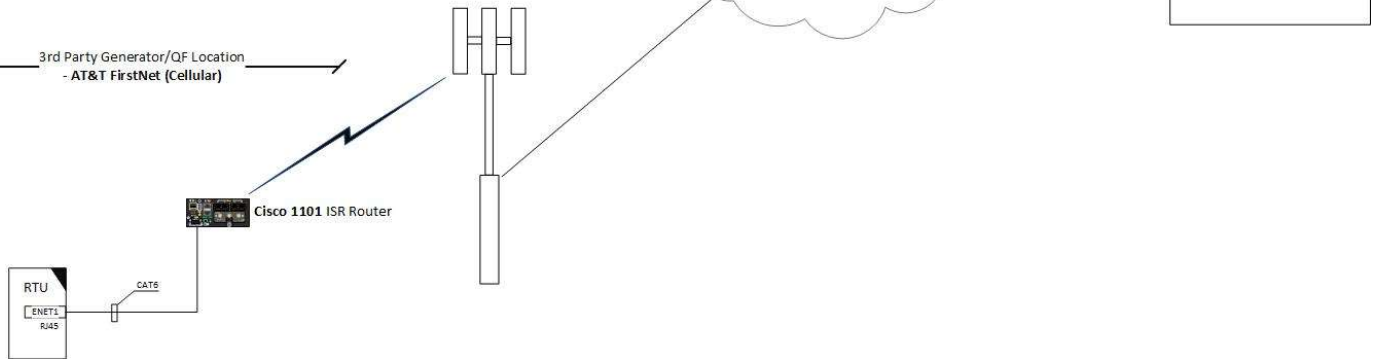

Internal

AF-23

Internal

Figure F-2 GENERATION WITH LOCKOUT RELAY

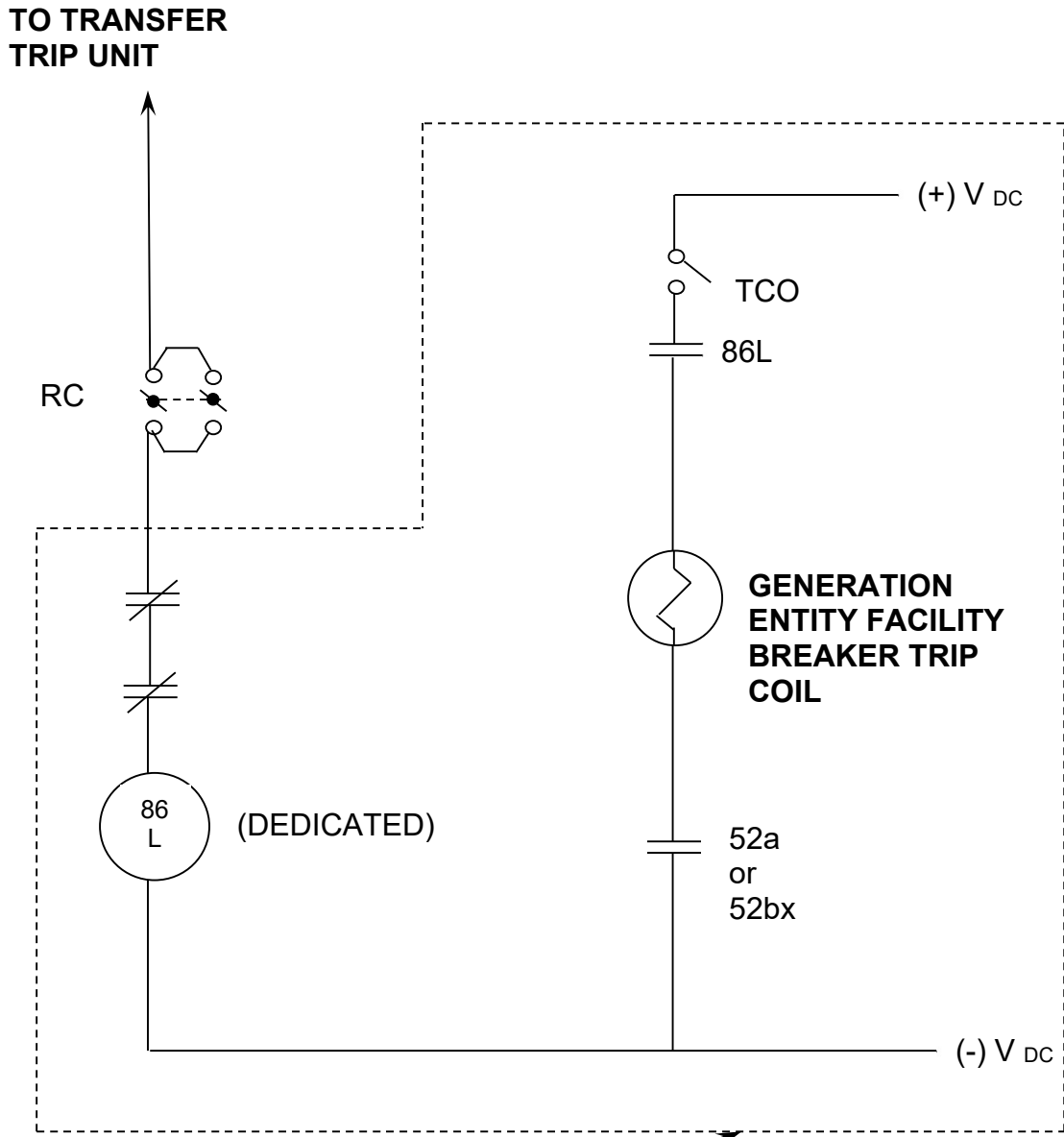

GENERATION ENTITY FACILITY

Legend:

- 52a Breaker seal "a"
- 52bx Breaker seal "b" auxiliary
- 86L Lockout relay

Internal

June 12, 2023

AF-24

Internal

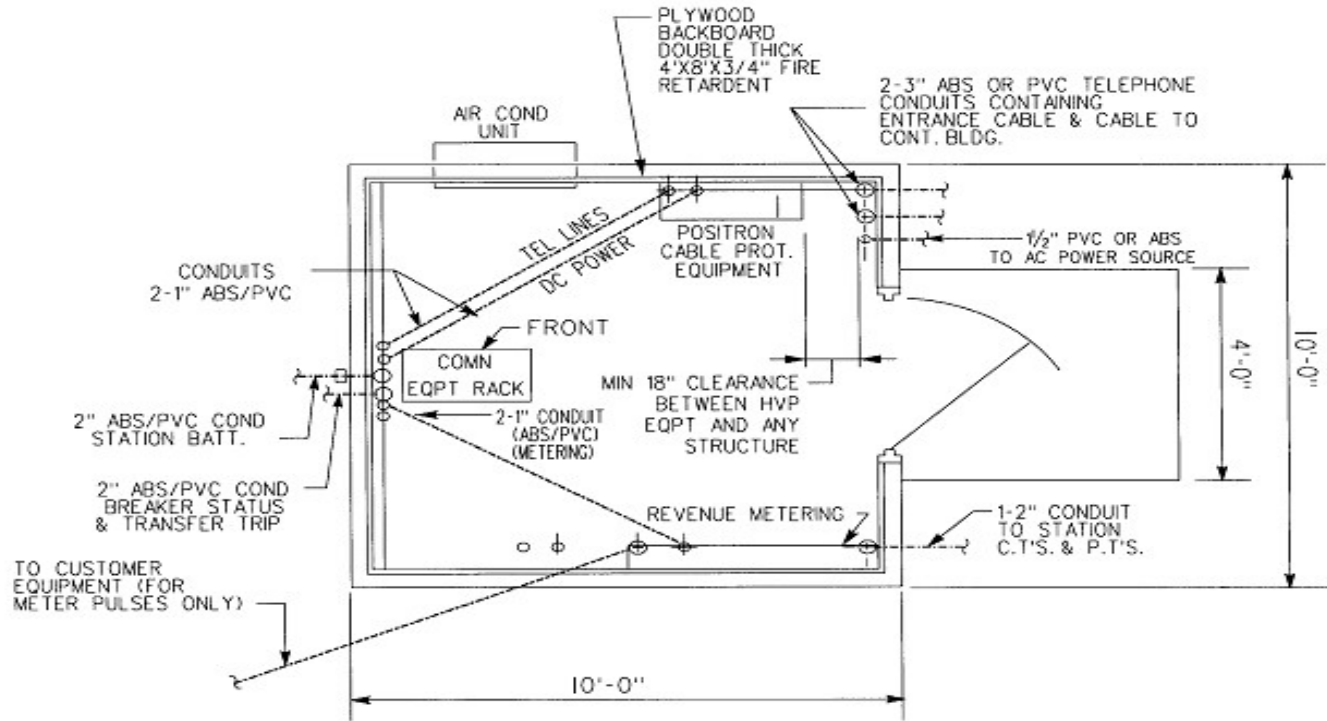

NOTE: RTU AND TRANSFER TRIP EQUIPMENT TO BE MOUNTED IN THE COMMUNICATIONS RACK

FIGURE F-4
SUGGESTED ROOM LAYOUT FOR SMALL GENERATORS

Internal

June 12, 2023

AF-25

Internal