



# **Apprentice LNG/CNG Technician (ALCT) Entrance Exam**

## **Preparation Guide**

---

## Table of Contents

Purpose .....	3
About the Exam.....	3
During the Exam.....	3
Computer-Based Exam Directions .....	4
Resources.....	7
Practice Problems .....	8
Practice Problem Answer Key .....	15

## Apprentice LNG/CNG Technician Entrance Exam

### Purpose

The Apprentice LNG/CNG Technician Entrance Exam is a computer-based knowledge test that is used in the selection process for hiring employees into the LNG/CNG Technician Apprenticeship program.

### About the Exam

- The Apprentice LNG/CNG Technician Entrance Exam allows you to demonstrate your knowledge, aptitude, and understanding of the fundamentals of basic mathematics, basic electricity, and mechanical concepts, as well as your preparedness for advanced technical training throughout your apprenticeship.
- There are **100** multiple choice and fill-in-the-blank questions on the exam and the total allotted time to take the exam is **3** hours and **25** minutes.

### Topics Covered in the Exam

- Mathematics
  - Addition, subtraction, multiplication, division
  - Fractions and decimals
  - Ratios
  - Algebra
  - Trigonometry
  - Geometry
  - Logic
  - Powers of ten
- Basic Electricity
  - Ohms Law
  - AC/DC power systems
  - Component function
  - Electrical Diagrams
- Instrumentation
  - Basic components
  - ANSI/ISA-95 Standard Symbology
  - Inputs/Outputs
- Process Control
- Mechanics
  - Ratios
  - General Mechanical Knowledge
- Tools
  - Basic knowledge of hand tools
- Physics and Chemistry
  - Pressure forces

## During the Exam

It is important that you follow the directions of the Test Administrator. If you have any questions about the testing session, be sure to ask before the testing begins.

Once you start the exam you may use the restroom but cannot leave the building. The time away from the computer will count towards the overall time limit for the exam.

All cellular devices, smart phones, smart watches, music players, earphones, personal calculators, cameras, or other electronic equipment will **NOT** be allowed in the testing area. Please secure these items **before** entering the testing location. Employees will need to complete LiveSafe prior to checking in and will secure their cell phones as they enter the testing room.

You will **NOT** be able to use your own calculator during testing. The Test Administrator will provide you with a non-programmable scientific calculator that you must use for the exam.

The Test Administrator will provide the following materials:

- Calculator: **Texas Instruments TI-30Xa**
- Scratch Paper
- Pencils

Once the exam has been submitted for scoring, the Test Administrator will collect all material.

## Computer-Based Test Directions



The Apprentice LNG/CNG Technician (ALCT) Entrance Exam is a computer-based test.

You will be seated at a computer testing station. The Test Administrator will assist with launching the exam. You will be asked to enter your candidate ID and password; this information will be provided by the Test Administrator.

You only need minimal computer experience and typing skills. You will only use the keyboard for minimal entries (information to identify you and a password). You will answer all questions with a computer mouse.

A test time will be visible throughout the exam in the top right corner. The time will start once you launch the exam. The exam automatically closes when the time limit expires. If the exam times out before you submit, the exam will end, and any unanswered questions are scored as incorrect.

---

Block 1 of 1 Time remaining:: 02 : 15 : 00  

When you have selected your answer to a question, click the “Next Question” button in order to move to the next question. To return to a question, click the “Previous Question” button.

Answers can be changed any time during the exam until the time runs out or when you click the “Submit” button. **Once you click “Submit”, you cannot change your answers.** Please do not select “Submit” until all questions have been answered. If you click “Submit” by mistake, you will receive a display warning box. Click “Cancel” if you want to continue working.



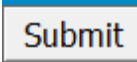

The “Assessment Navigator” will help identify questions that have been answered.

- Orange = unanswered question
- White = answered question

In the example below, questions 6 and 13-19 have not been answered, while 1-5 and 7-12 have been answered.

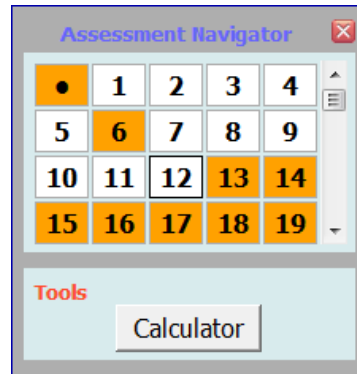
In addition, you can use the “Assessment Navigator” to jump to a particular question by clicking on the question number.



The “Flag” button , at the bottom of the window, allows you to mark a question for further review. When you click on the “Flag” button, this adds a black corner to the question number in the “Assessment Navigator”. In the example below, question 6 has been flagged. Click the “Flag” button again to un-flag the question.

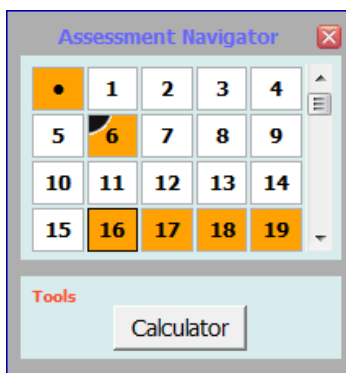

Below is an example of what you can expect to see when taking the computer-based test.

The screenshot shows a test interface for PG&E Academy. At the top, it displays the date 'Apr 16 2014', the user 'Logged in as: Testers Name', 'Block 1 of 1', and 'Time remaining: 02:15:00'. The main content area shows a question: '83 of 95 Potentiometers have \_\_\_ terminals, while rheostats have \_\_\_ terminals.' with three radio button options: '2, 3', '3, 2', and '4, 2'. The '3, 2' option is selected. Below the question, there are navigation buttons: '< Previous Question', 'Next Question >', 'Assessment Navigator', and 'Submit'. An 'Assessment Navigator' window is open, showing a grid of question numbers from 75 to 94. Question 81 is highlighted with a flag icon. A 'Tools' section at the bottom of the window contains a 'Calculator' button. Annotations with arrows point to various elements: 'Question with responses' points to the question text; 'Time Remaining' points to the timer; 'Font Size increase/decrease and contrast icons' points to the icons next to the timer; 'The Assessment Navigator will help identify questions that have been answered' points to the Assessment Navigator window; 'To move forward to the next questions or backwards' points to the 'Previous Question' and 'Next Question' buttons; 'Flag icon, mark a question for further review' points to the flag icon in the Assessment Navigator; and 'To send in the test, click Submit.' points to the 'Submit' button.

**Note:** During the exam if you experience any technical issues, raise your hand for assistance.

## Resources

The Internet is an excellent resource for much of the information to prepare for this exam. Many excellent mathematics, basic electricity, and electronics books are available from libraries, bookstores, and on-line resources. A general reference book is invaluable as a supplement to other textbooks from classes or specific subjects, and as an instrument for general review in preparing for qualifying tests. However, it is not a substitute for formal education and training.

The following are suggested resources to review:

- *Electricity: Principles and Applications* by Richard Fowler
- *Instrumentation and Process Control* by Kirk, Weedon, and Kirk
- *Control Loop Foundation – Batch and Continuous Processes* by Blevins and Nixon
- ANSI/ISA-95 Instrumentation Standards

Additional resources for improving understanding of the concepts may be found at local libraries, online, and bookstores.

Make sure that you are physically and mentally alert when you are scheduled to take your test.

We hope you find this information helpful.

Pacific Gas and Electric Company wishes you the best of luck in qualifying on your exam.



## Formulas and Symbols

The following formulas and symbols will be helpful when taking the test.

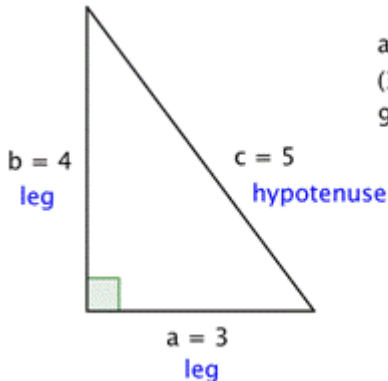
<b>Mathematics</b>	
<b>Order of Operations</b>	PEMDAS= Parenthesis, Exponents, Multiply or Divide, before you Add or Subtract
<b>Basic Operations</b>	Addition Subtraction Multiplication Division Place values (tenths, hundredths, thousandths, etc.) Ratios Fractions <ul style="list-style-type: none"> <li>• Simplest Terms</li> <li>• Addition</li> <li>• Subtraction</li> <li>• Multiplication</li> <li>• Division</li> </ul>
<b>Pythagorean Theorem</b>	$a^2 + b^2 = c^2$  $a^2 + b^2 = c^2$ $(3)^2 + (4)^2 = (5)^2$ $9 + 16 = 25$

## Trigonometry

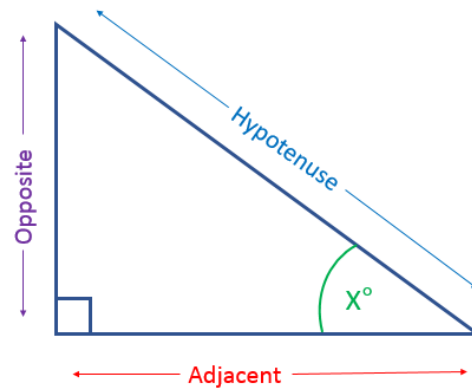

$$\text{Sine} = \frac{\text{Opposite}}{\text{Hypotenuse}}$$

$$\text{Cosine} = \frac{\text{Adjacent}}{\text{Hypotenuse}}$$

$$\text{Tangent} = \frac{\text{Opposite}}{\text{Adjacent}}$$

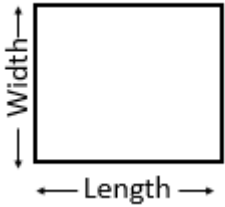
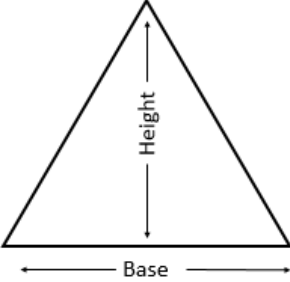
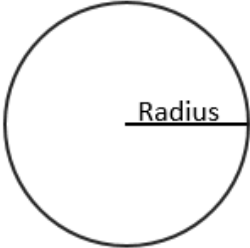
<b>Area</b>	Rectangle 	<b><math>Area = Length \times Width</math></b>
	Triangle 	<b><math>Area = \frac{(Base \times Height)}{2}</math></b>
	Circle 	<b><math>Area = \pi \times radius^2</math></b>
<b>Linear Algebra</b>	Used to determine position on a line	<b><math>y = mx + b</math></b>

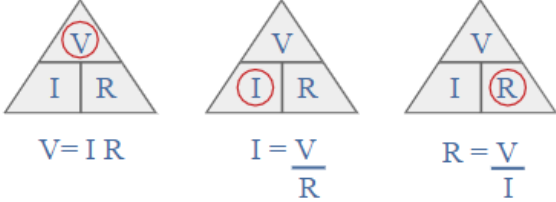
Basic Electricity	
<b>Ohm's Law</b>	 <p>                     V = voltage expressed in Volts                      I = current expressed in Amps                      R = resistance expressed in Ohm                 </p>

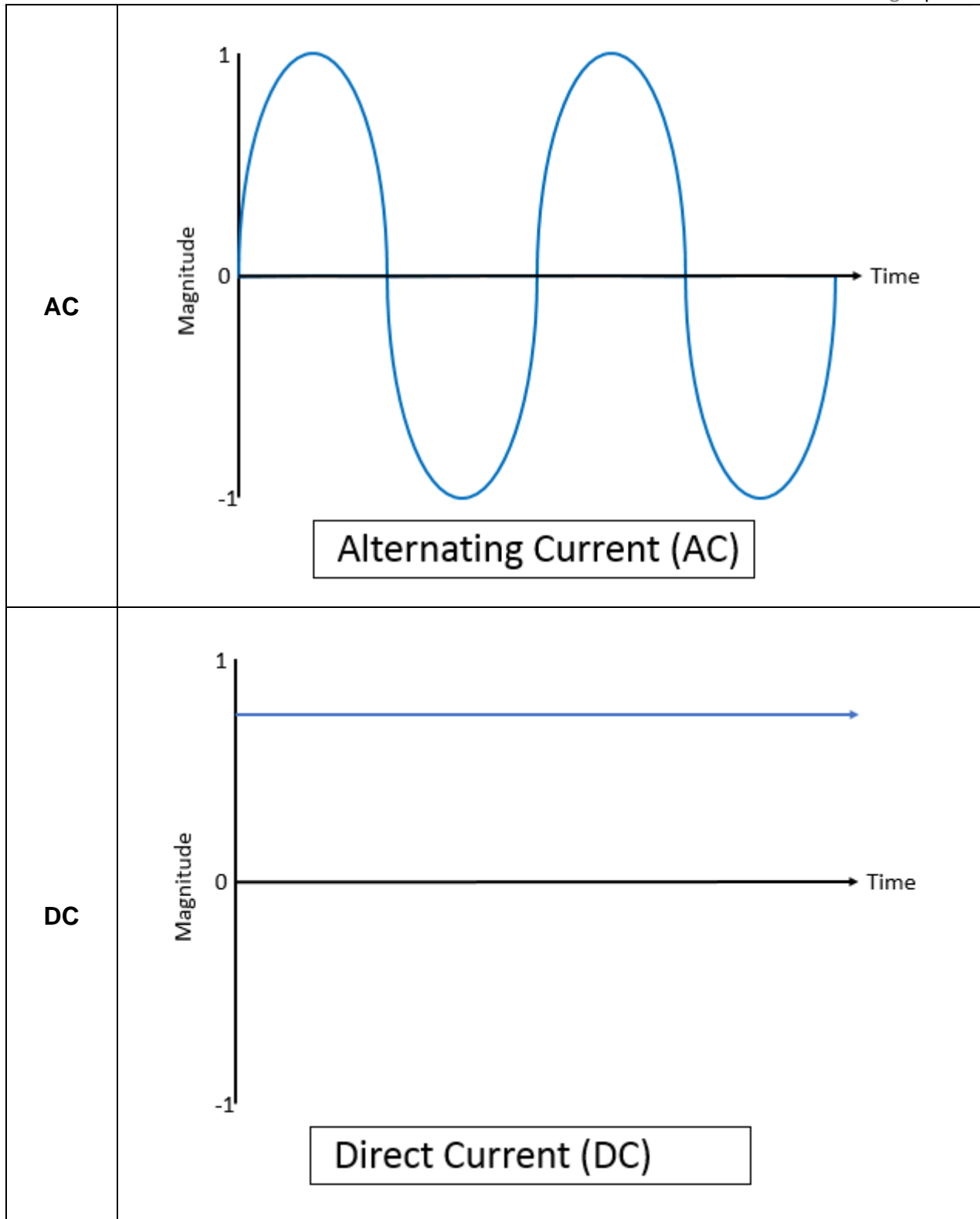

## Instrumentation

Below are a selection of symbols according to the ANSI/ISA-95 Instrumentation Standards. This selection provides an idea of the types of symbols which you will use in the field and will be covered on the exam. Please note that these do **NOT** cover **ALL** standard or PG&E specific symbols.

You can find additional symbols in the ANSI/ISA-95 Standards, and in the *Instrumentation and Process Control* textbook by Kirk, Weedon, and Kirk.

ANSI/ISA-95  
Standard  
Symbols

Discrete Instrument,  
field mounted



Discrete instrument,  
accessible to operator



Visible on video Display



Figure 7-11. Excerpt from ISA-5.1 General Instrumentation or Symbol Function

General Symbol

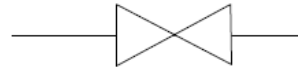

Ball Valve



Globe Valve

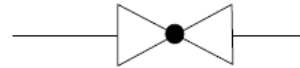

Damper

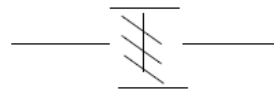
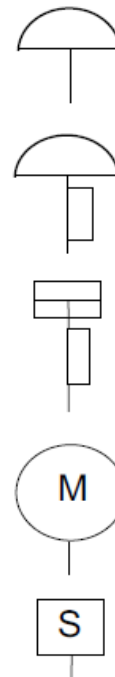

Figure 7-12. Excerpt from ISA-5.1 Valve Body and Damper Symbols

- Generic actuator, Spring-diaphragm
- Spring-diaphragm with positioner
- Linear piston actuator with positioner
- Rotary motor operated actuator
- Solenoid actuator for on-off valve



**Figure 7-13. Excerpt from ISA-5.1 Actuator Symbols**

Restriction Orifice, With Flow Transmitter



Hand Valve



Inline Measurement



Measurement Element

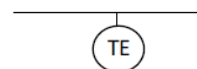

**Figure 7-14. Excerpt from ISA-5.1 Symbols for Other Devices**



This table is intended to provide insight to how symbols are labeled on a diagram. While you are not expected to memorize this table for this test, you should have a general idea of what the letters may mean for instruments. Sample commonly used tags in the Natural Gas industry are noted in **BOLD** text and highlighted in either Blue or Orange.

Instrument  
Tag ID  
Table

	First Letter		Second Letter		
	Measured or Initiating Variable	Modifier	Readout or Passive Function	Output Function	Modifier
A	Analysis		<b>Alarm</b>		
B	Burner Flame			<b>Control</b>	
C	Conductivity				
D	Density or Specific Gravity	<b>Differential</b>			
E	<b>Voltage</b>		Primary Element		
F	<b>Flow Rate</b>	Fraction/ Ratio			
G	Gaging (Dimensional)		Glass		
H	<b>Hand/ Manually Ctrl</b>				High
I	<b>Current</b>		<b>Indicate</b>		
J	Power	Scan			
K	Time			Control Station	
L	Level		Light (Pilot)		Low
M	Moisture				Middle or Intermediate
N					
O			<b>Orifice (Restriction)</b>		
P	<b>Pressure</b>		Point		
Q	Quantity or Event	<b>Total, Integrate</b>			
R	Radioactivity		<b>Record or Print</b>		
S	<b>Speed or Frequency</b>	<b>Safety</b>		Switch	
T	<b>Temperature</b>			<b>Transmit</b>	
U	Multivariable		Multi-function	Multi-function	Multi-function
V	Viscosity, Vibration			<b>Valve, Damper, Louver</b>	
W	Weight, Force		Well		

	First Letter		Second Letter		
	Measured or Initiating Variable	Modifier		Measured or Initiating Variable	Modifier
X					
Y	Event or State			Relay or Computer	
Z	Position			Drive, Actuate	

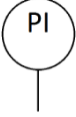
For example:

Symbol	First Letter(s)	Second Letter(s)	Instrument
	T	I	Temperature Indicator (Temperature Gauge)
	P	I	Pressure Indicator (Pressure Gauge)
	F, Q	Y	Total Flow Computer

**Mechanics**

**Sample tool list used by LNG/CNG Technicians:**

Screwdrivers	Drills	Drill Bits
Tape Measure	File	Saws
Torque Wrench	Vise	Pipe Wrench
Crescent Wrenches	Tubing Benders	Pressure Gauges
Wire Strippers	Wire Cutters	Multimeter
Mallets/Hammers	Pipe Cutter	

**Physics**

**Gas Laws**

Boyle's Law

$$P_1 \cdot V_1 = P_2 \cdot V_2$$

Charles's Law

$$\frac{V_1}{V_2} = \frac{T_1}{T_2} \text{ or } \frac{V_1}{T_1} = \frac{V_2}{T_2}$$



## Practice Problems

## Math

1. What part of the object is shaded?

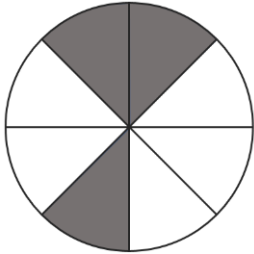

\_\_\_\_\_ fraction

\_\_\_\_\_ decimal

\_\_\_\_\_ percent

2. Find the length of "c" in the triangle below:

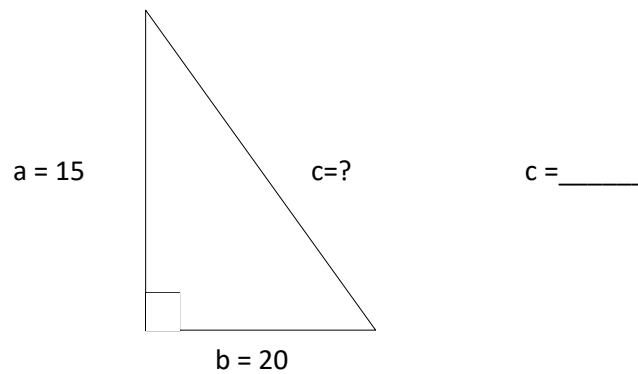

Use the triangle below for the next four questions.

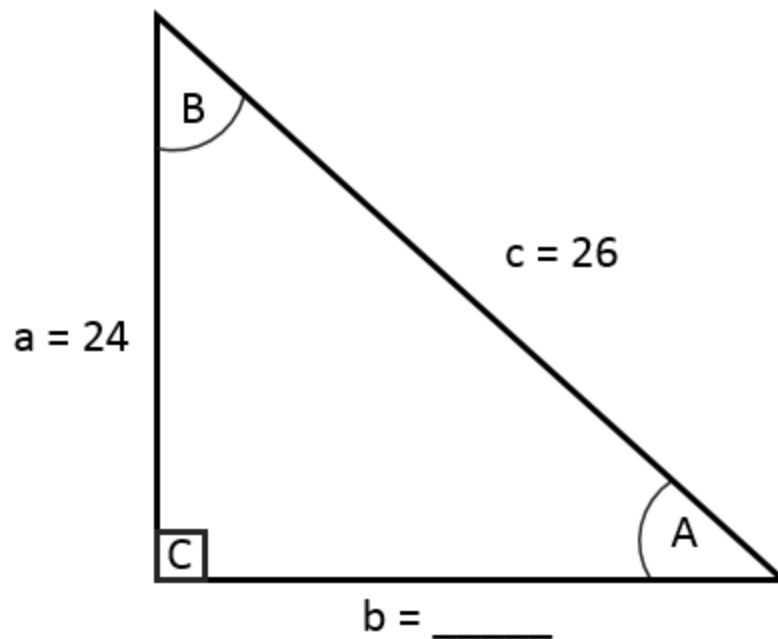

3. What is the length of side “b” in the triangle below? Side b = \_\_\_\_\_
4. What is the measurement of angle A, to the nearest tenth?  $\angle A = \underline{\hspace{2cm}}$
5. What is the measurement of angle B, to the nearest tenth?  $\angle B = \underline{\hspace{2cm}}$
6. What is the measurement of angle C, to the nearest tenth?  $\angle C = \underline{\hspace{2cm}}$

7. Complete the pattern? 12, 16, 20, \_\_\_\_\_, 28
8. How many meters are there in 900mm?
9. Solve the following equation, rounding to the nearest hundredth:

$$2.25(3.14)(0.678) = \underline{\hspace{2cm}}$$

10. What is 9% of 64.52, rounded to the nearest hundredth? \_\_\_\_\_
11. Solve the following equation:

$$(-1)(-4) = \underline{\hspace{2cm}}$$

12. Solve the following equation:

$$\frac{(-8 + 3)}{(7 + (-3))} = \underline{\hspace{2cm}}$$

13. Subtract and express in simplest terms:

$$15\frac{2}{3} - 3\frac{1}{2} = \underline{\hspace{2cm}}$$

14. A pressure transducer with a range of 0 – 1000 psig is installed in a control system where it outputs 1 – 5 vdc. What voltage signal would you expect when the pressure transducer senses 675 psig? \_\_\_\_\_
15. Assuming  $\pi = 3.14$ , what is the area of a circle with a diameter of 5 feet, rounded to the nearest hundredth? \_\_\_\_\_

### Electrical

16. According to Ohm's Law, what happens to current as resistance increases? \_\_\_\_\_
17. If three 6V 30 amp/hr batteries are installed in series, what is the available voltage?
- 6V
  - 12V
  - 18V
18. If two 6V 30 amp/hr batteries are installed in parallel, what is the available current?
- 15 amp/hr
  - 30 amp/hr
  - 60 amp/hr

19. What electrical component allows current to flow in only one direction?
- Transformer
  - Conductor
  - Diode

### Instrumentation

20. Which of the below symbols represents a Hand Valve on a Piping and Instrumentation Diagram, according to the ANSI/ISA-95 standards?

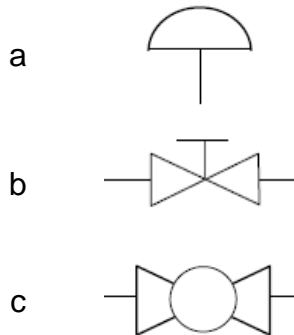

21. What instrument does the following symbol represent on a Piping and Instrumentation diagram?



- Motor
  - Pressure Gauge
  - Linear piston actuator with positioner
22. A 15 lb. frozen turkey and a 3 lb. bag of potatoes are dropped from a delivery drone traveling approximately 150 ft in the air. Which will reach the ground first?
- Turkey
  - Potatoes
  - Both at the same time

Use the diagram below to answer the following 3 questions:

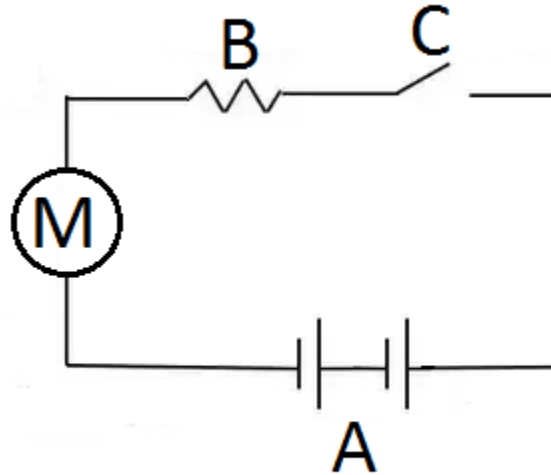

23. Complete the statement: The batteries in the circuit are installed in a \_\_\_\_\_ circuit configuration.
- Series
  - Parallel
  - Combined
24. What does component “B” do to the current in the circuit?
- Increases
  - Decreases
  - It has no effect
25. When switch “C” is closed, in which direction does current flow out of “A”?
- Left
  - Right
  - Both directions

**Practice Problem Answer Key**

1.  $\frac{3}{8}$ , 0.375, 37.5%
2. 25
3. 10
4.  $67.4^\circ$
5.  $22.6^\circ$
6.  $90.0^\circ$
7. 24
8. 0.9 m
9. 4.79
10. 5.81
11. 4
12. -1.25
13.  $12\frac{1}{6}$
14. 3.70 vdc
15.  $19.63 \text{ ft}^2$
16. Decreases
17. C – 18V
18. C – 60 amp/hr
19. C – Diode
20. B
21. C
22. C – Both at the same time
23. A - Series
24. B - Decreases
25. B - Right