	<b>TEMPORARY UNDERGROUND ELECTRIC SERVICE SINGLE-PHASE, 120/240 VOLT, 200 AMPS MAXIMUM</b>		<b>036670</b>
	<b>Asset Type:</b> Electric Metering	<b>Function:</b> Design and Construction	
<b>Issued by:</b> Quoc Hoang (QxH1) 	<b>Date:</b> 07-31-15		
<b>Rev. #04:</b> This document replaces PG&E Document 036670, Rev. #03. For a description of the changes, see Page 4.			

**This document is also included in the following manuals:**

- [Gas and Electric Service Requirements \(Greenbook\)](#)
- [Electric Meter Work Practices](#)

**Purpose and Scope**

This document shows minimum requirements for a customer-installed wood post or portable structure for temporary installation of a single-phase 120/240 V 200-amp maximum underground electric service. PG&E cannot establish service to posts which do not meet these minimum requirements. The maintenance of customer-owned service posts in conformity with these requirements is the sole responsibility of the customer.

**General Information**

1. Local ordinances may include requirements in addition to those shown in this document. Consult local inspection authorities for these requirements. In areas where local ordinances require permits and inspection, these must be obtained before PG&E can establish service. Meters will be installed and energized by PG&E after the customer's metering equipment has been properly installed and after an inspection clearance has been given to PG&E by the appropriate electrical inspection authority.
2. Definition of a "temporary service:" Service for enterprises or activities which are limited to one year or less in duration.
3. If temporary overhead wires are to be extended from poles, the poles shall conform to requirements of [G.O. 95](#), as shown in [Document 025055](#).
4. Customer shall install conduit and cable as required by local codes.
5. The customer must contact the Underground Service Alert (USA) or PG&E to locate and mark underground facilities in the work area. Failure to do so can result in injury to personnel and/or costly damage to utility facilities.
6. When single-phase service larger than 200-amps or three-phase service is desired, consult PG&E.
7. Service Post Installation (see Page 3)
  - A The use of temporary service posts shall be restricted to installation of a temporary nature, such as building construction, temporary sales locations, etc. Temporary service posts shall be furnished and installed by the customer. If the temporary service is to be established at the permanent meter location, consult PG&E.
  - B Minimum dimensions of posts shall be 4" x 6" x 7' 0" long and depth of setting shall be 24 inches minimum.
  - C Post installations shall be in protected locations, out of the way of vehicular traffic or other hazardous conditions.
8. Service to Substantial Portable Structure (see Page 4)
  - A Portable buildings, such as small sheds, combined office/toilet structures, etc., are not considered to be substantial structures unless staked in place in the manner shown in Figure 3 on Page 4.
  - B Temporary underground service to a portable building will only be connected to a substantial portable structure. For definition of substantial portable structure and method of installation, see Figure 3 on Page 4, Note 8A on Page 1, and Note 1 on Page 4.

**Temporary Underground Electric  
Service Single-Phase, 120/240 Volt, 200 Amps Maximum**

---

9. Grounding

The customer shall be responsible for bonding and grounding all exposed non-current-carrying metal parts. Grounding shall be in accordance with the National Electrical Code and local ordinances except that the grounding wire shall be protected against mechanical damage by rigid steel conduit or armored copper ground wire may be used (minimum #8 AWG copper). For installation, see Figure 1 on Page 3.

10. Service Trench

The minimum conduit depth shown in Figure 1 on Page 3 and Figure 3 on Page 4, may be reduced from 24 inches to 18 inches for the length of the customer's service trench. However, in the vicinity of PG&E's splice box, the conduit depth must be 24 inches to assure proper entry into boxes' conduit knockout. Splice boxes without extensions do not require a 24-inch trench depth at the box location. Contact PG&E to determine if the splice box has an extension.

<b>References</b>	<b>Location</b>	<b>Document</b>
<a href="#">Requirements for Customer-Owned Poles</a> .....	<a href="#">OH: Services</a> .....	<a href="#">025055</a>
<a href="#">Rules for Overhead Electric Line Construction</a> .....	<a href="#">Technical Information Library</a> .....	<a href="#">G.O. 95</a>

## Temporary Underground Electric Service Single-Phase, 120/240 Volt, 200 Amps Maximum

### Service Post Installation

#### Notes

1. The customer's cables will be connected by PG&E. The customer is to contact PG&E when they are ready to extend the conduit and cable into the splice box. Customer runs adequately insulated unstripped cable into the splice box. Customer's cables are to extend a minimum of 24 inches into the splice box.
2. PG&E secondary splice box is normally located adjacent to the sidewalk. Consult PG&E for exact location. If a splice box is not present, PG&E will install an appropriate splice box at the customer's expense.
3. Conduit is to enter the splice box through knockout positions only.
4. Meter height can be reduced to a minimum of 36" if the meter is enclosed or guarded by a hinged protective hood.

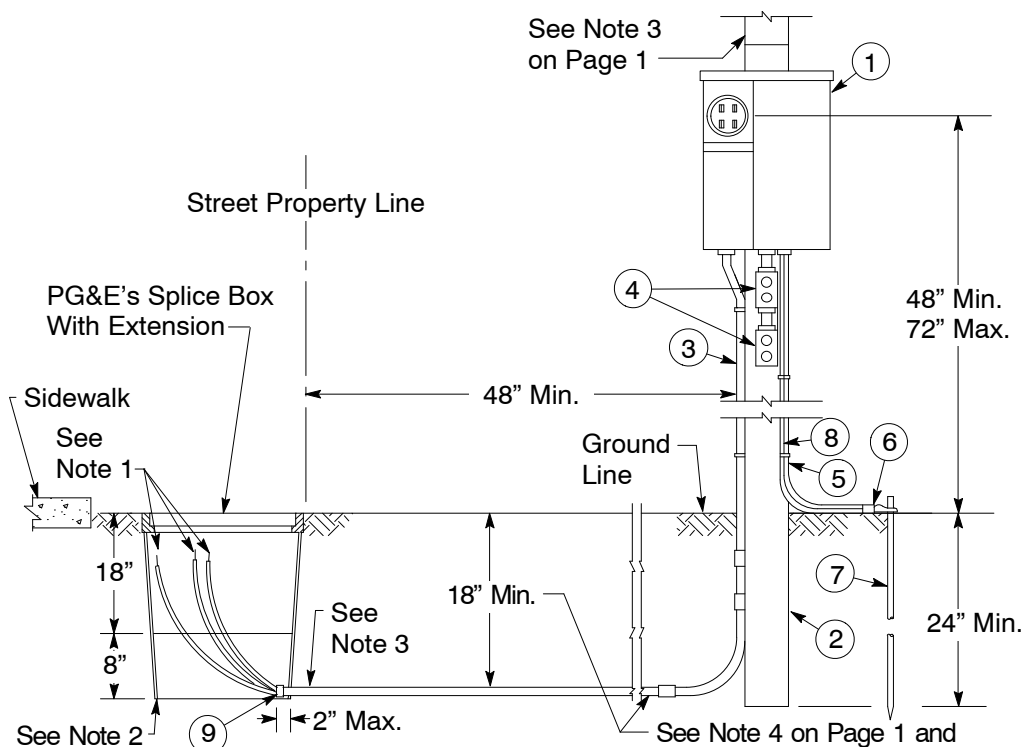

**Figure 1**  
**Service Post Metering**  
**Preferred Installation**

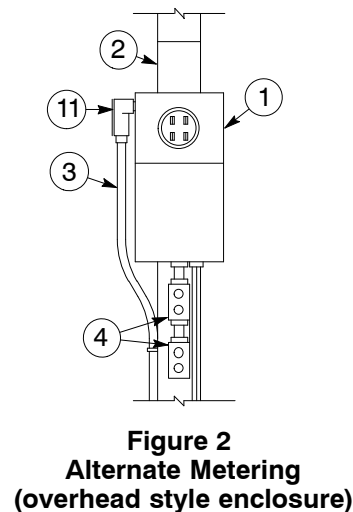

**Figure 2**  
**Alternate Metering**  
**(overhead style enclosure)**

**Table 1 Materials to be Furnished and Installed by the Customer**

Item	Description
1	Service Termination Enclosure, Combination Meter Socket Panel
2	Post, Minimum Dimension 4" x 6" x 7' 0" Long (see Note 7B on Page 1)
3	Conduit, Rigid Steel, Galvanized, or Schedule 80 Pvc 1-1/2" Minimum I.D. for #2 or 1/0 Aluminum Service Cable
4	Weatherproof Outlets
5	Conduit, Rigid Steel, Galvanized, With Pipe Strap (for bare ground wire, omit if armor clad wire used)
6	Hub and Clamp, Grounding, to Suit Item 5
7	Ground Rod (see Note 9 on Page 2)
8	Ground Wire, Copper, Bare or Armor Clad (size in accordance with applicable electrical codes and local requirements)
9	Conduit Bushing or Bell End (as required)
10	Service Termination Enclosure, 8" x 12" x 4", Rain-Tight, Circle AW No. R-9007A or Equivalent (see Note 2 on Page 4)
11	Conduit Fitting, Threaded With Cover and Gasket (size to suit Item 3)

**Temporary Underground Electric  
Service Single-Phase, 120/240 Volt, 200 Amps Maximum**

**Commercial Service to Substantial Portable Structure**

**Notes**

1. Structure Anchoring: To prevent overturning, the structure is required to be securely anchored in place using one of the following methods:
  - A. Four 2" x 4" minimum wood stakes driven a minimum of 24 inches into the ground and attached to the framework of the structure using 1/4-inch minimum bolts or lag screws.
  - B. Four steel stakes having strength equivalent to 3/4-inch rigid steel pipe driven a minimum of 24 inches into the ground and attached to the framework of the structure using 1/4-inch minimum bolts or lag screws.
  - C. Four steel stakes having strength equivalent to 3/4-inch rigid steel pipe driven a minimum of 24 inches into the ground with a cross member of each stake firmly contacting the upper surface of the timber used as a base or skid for the structure.
  - D. Methods A and B described the *preferred* methods of attaching the stakes to the structure framework. However, four 16d (8 gauge 3-1/2") common nails per stake may be used in lieu of the bolts or lag screws, providing the wood is in good enough condition to permit a secure attachment.
2. Item 10 may only be used if the service conductor is 1/0 AWG or smaller.

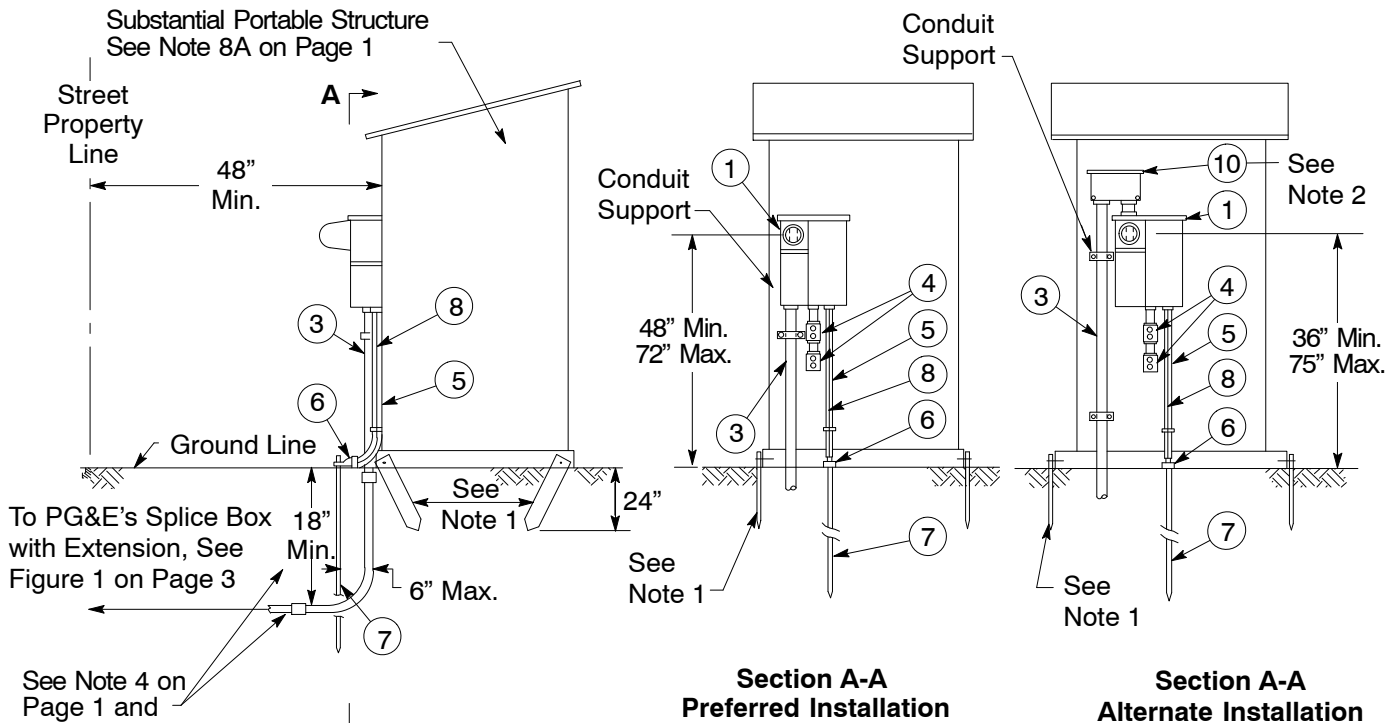

**Revision Notes**

Revision 04 has the following changes:

1. Revised 100 Amp to 200 Amp maximum.
2. Revised Note 1 on Page 3 :customer is to contact PG&E when they are ready to extend the conduit and cable into the splice box.