	CONNECTORS FOR INSULATED CABLES UNDERGROUND DISTRIBUTION SYSTEMS	015251
Asset Type:	Electric Distribution	Function: Design and Construction
Issued by:	Liseth Villareal (LDV2) <i>Liseth Villareal</i>	Date: 06-30-23
Rev. #08: This document replaces PG&E Document 015251, Rev. #07. For a description of the changes, see Page 39.		

Purpose and Scope

This document provides application and ordering information for cable connectors and terminals for use in underground distribution systems.

General:

This document applies to connectors for copper-to-copper, copper-to-aluminum, and aluminum-to-aluminum conductors. The use of aluminum conductors and the necessity of splicing aluminum-to-copper presents some specific problems as follows.

1. All connectors shall meet the requirements of **ANSI C119 Class A**.

2. Oxide Film

Unlike copper, aluminum is normally covered with a thin, hard film of invisible aluminum oxide. This film is a good insulator and forms immediately whenever aluminum is exposed to air. Therefore, aluminum connectors must meet the following requirements.

- A. Connectors should exert sufficient pressure on the cable to break through the oxide film.
- B. Connectors should exert approximately equal pressures on all strands.

3. Thermal Expansion and Plastic Flow

The difference in the thermal expansion of copper and aluminum must be addressed. Aluminum expands and contracts approximately 38% more than copper with the same temperature change. Copper connectors and copper cables expand together as do aluminum connectors and aluminum cables.

If copper connectors are used on aluminum cables, the aluminum cable expands more than the copper connector. As the temperature rises this causes the aluminum to extrude out of the connector. When the joint cools, the copper connector cannot shrink to fit the reduced diameter of the aluminum conductor. This cycle, repeated over time, results in loose connections and high resistance joints. Therefore, it is important to use connectors that have the same coefficient of expansion as the cable. For example, copper connectors with copper cable and aluminum connectors with aluminum cable.

Aluminum-to-copper connections must be made with special aluminum connectors designed to run cooler than the copper conductor and compensates for the difference in the coefficient of expansion. These connectors have a larger mass than standard aluminum connectors.

4. Corrosion

- A. **Electrolysis:** The third characteristic of aluminum that affects connectors is not peculiar to aluminum alone but is common to all metals. Aluminum in contact with another metal in the presence of moisture will have an electrolysis action.

This problem exists in the connection of aluminum-to-copper, and the electrolysis action causes corrosion of the anode material (aluminum), leaving the cathodic material (copper) undamaged.

- B. **Chemical:** Moisture in the absence of air reacts with aluminum forming aluminum hydroxide, which, in a very short time, will seriously corrode the aluminum material.

It is of extreme importance that aluminum conductors and connectors installed underground be free of moisture. Special care must be used to prevent moisture from entering into underground splices by using an inhibitor, and carefully and correctly taping or sealing splices.

**Connectors for Insulated Cables
Underground Distribution Systems**

5. General Rules for Battery Presses.

- A. A 6-ton in-line or pistol grip battery-powered press is equivalent to the older mechanical hand tools used for pressing connectors - for example, the Burndy MD6-8 tool.
- B. A 6-ton tool uses the same dies and the same number of compressions that the mechanical hand tool does.
- C. If the connector is stamped with a die designation of HYD, it means a 12-ton tool is necessary with a U die. In the past only 12-ton presses were hydraulic. Examples:
 - A Kearney 303 connector shows “HYD O DIE”. This means a 12-ton tool with a U-O die (with 1 compression) is required. An O die in a 6-ton tool is not sufficient.
 - A Kearney 308 connector shows “HYD D OR D3 DIE”. This means a 12-ton tool with a U-D or U-D3 die (with 1 compression) is required.
- D. If the connector is stamped with a die designation of HAND or MEC, it means a 6-ton tool can be used with a W die. Example:
 - A Kearney 302 connector shows “HYD B – MEC K”. This means a 6-ton tool with a W-KK die (with 3 compressions) can be used or a 12-ton tool with a U-B die (with 1 compression) can be used. The 6-ton tool is much lighter than the 12-ton tool and is preferred for ergonomics.

6. For information on multi-tap splices for 600V insulated cable refer to [Document 036640](#)

7. All information for field drilling connectors has been removed in revision (06). Use range taking connectors (shearbolt) when dealing with non-standard cable sizes.

8. Ground terminal connector has been replaced with a more robust design. See Table 12 on page 15.

Application

1. There are four general types of connectors: solder sweated, bolted, compression, and shear-bolt. The advantages, disadvantages, and normal application of these four types of connectors are described in Table 1.
2. Compression tap connectors, Pages 16 through 19, are the preferred connectors for residential and light commercial installations.

Table 1 UG Connector Comparison

Connector Type	Application	Advantages	Disadvantages
Solder Sweated Split Tinned Copper ¹	For Copper-to-Copper Straight Connections (Page 14)	<ul style="list-style-type: none"> • Inexpensive • Excellent Electrical Connection 	<ul style="list-style-type: none"> • Special Tool Required • Must Be Sweated on (increasing time and labor) • Limited to Copper Cables
Bolted	Terminals and Tap Connections Rated Less Than 600 V (Pages 15, 31, 33, 35, and 36 - 37)	<ul style="list-style-type: none"> • Fast and Easy Install • Wide Range of Sizes • No Special Tools Required • Low Cost 	<ul style="list-style-type: none"> • More Difficult to Seal
Compression (preferred)	Straight and Tap Connections for Copper and Aluminum Cables (Pages 9 - 13, 17 - 30, and 38)	<ul style="list-style-type: none"> • Preferred Electrical Connection • Ease of Installation 	<ul style="list-style-type: none"> • Requires Specific Tools and Dies
Shearbolt	Straight and Y & H Cold-Shrink Splices	<ul style="list-style-type: none"> • Range Taking • Excellent Electrical Connection • Ease of Installation • No Special Tool Required 	<ul style="list-style-type: none"> • More Expensive







1. Use only with paper-insulated lead-covered (PILC) Cable.

**Connectors for Insulated Cables
Underground Distribution Systems**

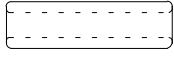
References	Location	Document
Joints for 15 kV Three-Conductor Paper-Insulated Lead-Covered Cable for Use on 12 kV Circuits	UG-2: Splices	022709
Method of Terminating 15 kV Paper Insulated Lead-Covered Cable	UG-2: Terminations	022820
Splice for Leaded to Non-Leaded Cable	UG-2: Splices	022824
Splice for 5 kV and 15 kV Type RO&N Cable Single Conductor Shielded	UG-2: Splices	022827
Street Light Cable Splices	UG-2: Splices	022830
Splice for Varnished Cambric Insulated Cable With Flameproof Jacket	UG-2: Splices	022832
Installation of Cable Risers on Wood Poles	OH: Risers/UG-1 Terminations	027742
Joints for 15 kV & 25 kV Single Conductor Paper Insulated Lead-Covered Cable for Use on 12 kV & 22 kV Circuits	UG-2: Splices	033585
Distribution Transformer Requirements, Single-Phase and Three-Phase, Overhead-Type	OH: Transformers	034963
Single-Phase, Subsurface, Round Transformers	UG-1: Transformers	035313
Installation of Subsurface, Load-Break, and Dead-Break Primary Junction	UG-1: Switches	035380
Multi-Tap Splice for 600-Volt Insulated Cables	UG-1: Splices	036640
Installation of 200-Amp, Subsurface Sectionalizing Switches	UG-1: Switches	039954
Cables for Underground Distribution	UG-1: Cable	039955
Compression-Type Connectors for Overhead Distribution and Transmission	OH: Conductors	041010
Installation of Live-Front, Low-Profile, Single-Phase, Pad-Mounted Transformers	UG-1: Transformers	042762
Installation of Three-Phase, Radial-Style, Pad-Mounted Transformers	UG-1: Transformers	043817
Method of Terminating 15 KV and 22KV I/O & Smaller Concentric Type Cable – XLP-CONC–PVC & XLP-CONC	ELS	043902
Installation of Loop-Style, Three-Phase, Pad-Mounted Transformers	UG-1: Transformers	045291
Installation of Three-Phase, 600-Amp, Subsurface Sectionalizing Switches	UG-1: Switches	050859
Straight and Tap Splice for 600 Volt Insulated Cable	UG-1: Splices	051034
600-Amp Separable Insulated Connectors	UG-1: Terminations	051071
Premolded 600-Amp Splices for Primary Underground Cables	UG-1: Splices	053732
Pad-Mounted Transformers Installed Indoors	UG-1: Transformers/Greenbook/EMWP	057521
Single-Phase, Dead-Front, and Duplex, Pad-Mounted Transformer Installations	UG-1: Transformers	064308
Cold Shrink 600-Amp Splices for Primary Underground Cable	UG-1: Splices	066204
Fired Wedge Connectors for Primary and Secondary Distribution Lines	OH: Conductors	066194
Straight Cold Shrink™ 15 KV Transition Splices	ELS	072152
Cold-Shrinkable Trifurcating 600-Amp 15KV Transition Splice	ELS	076245
Cold-Shrinkable Straight 600-Amp 15 KV Transition Splice	ELS	076246
Medium Voltage Y and H Splices for Manhole Applications	UG-2: Splices	076261
Grounding of Tape Shield and Flat Strap Neutral Cables	UG-1: General	076264

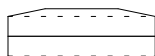
Connectors for Insulated Cables Underground Distribution Systems

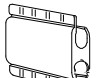
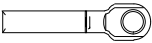

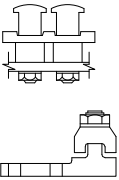
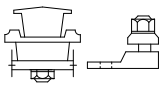
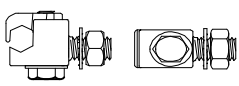
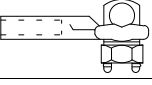

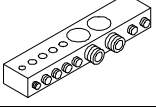
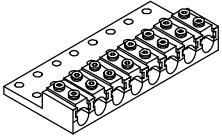

Table 2 Connectors – Pictorial Index

Connector	Type		Page	Application	
				Cable	Document ¹
	Straight Connectors	Compression	9 to 10	Copper-to-Aluminum	022824 022827 022830
			11 & 16	Aluminum-to-Aluminum	041583 043901 051034
			12 to 14	Copper-to-Copper	022709 022824 022827 022830 022832 033585 041583 043901 051034
			Shearbolt	2	Bi-Metal Copper or Aluminum
	Split Connectors	Solder	14	Copper-to-Copper	022709 022824 022827 022830 022832 033585 041583 043901 051034
	Tap Connectors	Bolted	15	Copper-to-Copper (San Francisco and Oakland Network only)	051034
		Compression	16 to 20	Aluminum-to-Aluminum or Aluminum-to-Copper (for secondary conductors)	
			20 to 24	Copper-to-Copper (for secondary conductors)	
	Terminal Connectors		25 to 30	Aluminum-to-Copper (for transformer spade terminals)	042762 043817 045291

¹ For a description of the application document, see “References” on Page 3.

**Connectors for Insulated Cables
Underground Distribution Systems**

Table 2 Connectors – Pictorial Index (continued)

Connector	Type		Page	Application	
				Cable	Document ¹
	Terminal	Compression	4	Bi-Metal Copper or Aluminum	051071
		Shearbolt	4		076261
	Terminal Connectors	Bolted	31 to 34	Copper (for transformer spade terminals, non-preferred)	028114 033701
	Terminal Connectors	Bolted	35	Copper (transformer terminals)	028114 033701
	Ground Terminal	Bolted	15	Copper (equipment tank grounds and primary concrete enclosures)	035313 035380 039954 050859
	Tap Connectors	Bolted	35	Copper-to-Copper	042762
			35	Copper-to-Aluminum	042762
	Slip-Fit Connectors	Bolted	36	Aluminum or Copper	064308
	Multiple Transformer Terminal	Bolted	37	Aluminum or Copper	043817 045291
	Pin Terminals	Compression	38 – 39	Aluminum or Copper	027742 041584 043902
Tool and Die Information		Compression	7	Copper Cables Aluminum Cables	-
			8		
Connectors for splicing or tapping concentric wires and flat straps		Compression	20 – 21	Copper Cables	039955

¹ For a description of the application document, see “References” on Page 3.

**Connectors for Insulated Cables
Underground Distribution Systems**

Tools and Dies for Compression Connectors

Table 3 Installation Information for Copper Cables

Tool Index No.	Hypress & Circular or Indentor Die ¹									
	Connector Nominal O.D.	Burndy Index No.	6-Ton Press	12-Ton Press			15-Ton Press		40-Ton Press	
			Circular Die	Circular Die	Nest Die	Circular Die	Circular Die ³	Circular Die ⁴	Circular Die	Nest Die
4C	.34	8	–	A4CR	A4CD	U4CRT	U4CRT	U4CRT	C4CR	–
2C	.42	10	–	A2CR	A2CD	U2CRT	U2CRT	U2CRT	C2CR	–
2CS	.50	163	W163	–	–	U163	–	U163	–	–
1C	.46	11	–	A1CR	A1CD	U1CRT	U1CRT	U1CRT	C1CR	–
1/0 C	.51	12	–	A25R	A25D	U25RT	U25RT	U25RT	C25R	–
2/0 C	.56	13	–	A26R	A26D	U26RT	U26RT	U26RT	C26R	–
3/0 C	.62	14	–	A27R	A27D	U27RT	U27RT	U27RT	C27R	–
4/0 C	.69	15	–	A28R	A28D	U28RT	U28RT	U28RT	C28R	C28D
250 C	.75	16	–	A29R	A29D	U29RT	U29RT	U29RT	C29R	C29D
300 C	.81	17	–	A30R	A30D	U30RT	U30RT	U30RT	C30R	C30D
350 C	.88	18	–	A31R	A31D	U31RT	U31RT	U31RT	C31R	C31D
400 C	.95	19	–	A32R	A32D	U32RT	U32RT	U32RT	C32R	C32D
500 C	1.10	20	–	A34R	A34D	U34RT	U34RT	U34RT	C34R	C34D
600 C	1.19	22	–	–	–	U36RT	U36RT	U36RT	C36R	C36D
750 C	1.30	24	–	–	–	–	112H	P39RT	C39R	C39D
1000 C	1.50	27	–	–	–	–	125H	P44RT	C44R	C44D
1500 C	1.84	31	–	–	–	–	–	–	C46R	C46D

¹ For reference purposes all available dies are shown. It is not intended that all dies indicated be provided with every tool.

² T & B equivalent: TBM15, 15500 Adapter.

³ Use UT15 tool with 15 CAP adapter on Burndy dies for #4 through 500 kcmil only.

⁴ A U-die adapter must be used when utilizing U-dies in a 15-Ton press.

**Connectors for Insulated Cables
Underground Distribution Systems**

Tools and Dies for Compression Connectors (continued)

Table 4 Installation Information for Aluminum Cables

Tool Index No.	Hypress & Circular or Indentor Die ¹									
	Conn. Nom. O.D.	Burdny Index No.	6 Ton Press	12-Ton Press			15-Ton Press		40-Ton Press	
			Circular Die	Circular Die	Nest Die	Circular Die	Circular Die ³	Circular Die ⁴	Circular Die	Nest Die
4A	.43	375	–	A4CAB	A1CD	U4CABT	U4CABT	U4CABT	C4CAB	–
2A	.53	348	–	A2CAB	A26D	U2CABT	U2CABT	U4CABT	C2CAB	–
1A	.54	471	–	A1CAB		U1CART	U1CABT	U1CABT	C1CARR	–
1/0 A	.60	296	–	A25AR	A27D	U25ART	U25ART	U25ART	C25AR	–
1/0 AS	.65	BG	W-BG ⁵	–	–	U-BG	U-BG	U-BG	–	–
2/0 A	.67	297	–	A26AR	A29D	U26ART	U26ART	U26ART	C26AR	–
3/0 A	.76	467	–	A27AR	A30D	U27ART	U27ART	U27ART	C27AR	–
4/0 A	.85	298	–	A28AR	A31D	U28ART	U28ART	U28ART	C28AR	–
4/0 AS	.90	249	W249	–	–	U249	U249	U249	–	–
250 A	.92	324	–	A29AR	A32D	U29ART	U29ART	U29ART	C29AR	–
300 A	1.01	470	–	A30AR	A34D	U30ART	U30ART	U30ART	C30AR	C34D
350 A	1.11	299	–	–	–	U31ART	U31ART	U31ART	C31AR	C35D
400 A	1.19	472	–	–	–	U32ART	U32ART	U32ART	C32AR	
500 A	1.32	300	–	–	–	U34ART	U34ART ⁶	U34ART	C34AR	C39D
600 A	1.44	473	–	–	–	U36ART	140H	U36ART	C36AR	C44D
700/750 A	1.60	301	–	–	–	–	140H	P39ART	C39AR	C45D
800 A	1.65	474	Y-60	–	–	–	140H	P40ART	C40AR	
1000 A	1.84	302	Y-60	–	–	–	150H/161R ⁷	P44ART	C44AR	C46D
1250 A	2.25	478	L44ART	–	–	–	–	–	–	–
1500 A	2.26	478	L46ART	–	–	–	–	–	–	–
1750 A	2.46	587	L47ART	–	–	–	–	–	–	–
2000 A	2.60	479	L48ART	–	–	–	–	–	–	–

¹ For reference purposes all available dies are shown. It is not intended that all dies indicated be provided with every tool.

² A U-die adapter must be used when utilizing U-dies in a 15-Ton press.

³ Use UT15 tool with 15 CAP adapter on Burdny dies for #4 through 500 kcmil only.

⁴ Use P-ADUPT adaptor die in Y46 to utilize all Y35 dies (ie., U-RT or U-ART).

⁵ The OH-25 handtool may be used on insulated service sleeves only.

⁶ Homac equivalent of this die is 106A.

⁷ 150H no longer available, either die is acceptable.

Applications of Straight Connectors Compression-Type (copper-to-aluminum)

Notes

1. Circular dies should be used on all primary and secondary splices. In these small sizes, the indent-type dies distort the connector.
2. Tool index numbers may be applied to in-line cable-to-cable limiters.
3. For the correct number of crimps, see the appropriate numbered document or the manufacturer's instructions on the package. When the information is not available, make as many non-overlapping crimps as possible without going over the outer end.
4. Pages 9 through 13 and 16 through 20 show compression-type connectors used to connect copper conductors to aluminum conductors. These connectors may also be used to connect aluminum-to-aluminum conductors.
5. Table 5 on Page 9 and Table 6 on Page 10 show compression splice connectors which accommodate specific conductor sizes.
6. Use a clean wire brush to remove oxides from the conductors prior to installing the connectors.
7. After the connector has been pressed on, insulating and sealing of pressed connections is accomplished in the same manner as shown in [Document 051034](#). Special attention must be given to the following:
 - A. Both ends of the aluminum connector should contain oxide inhibitor. Connectors shown in Table 5 on Page 9 and Table 6 on Page 10 are prefilled with inhibitor. See [Document 028852](#) for approved oxide inhibitors.
 - B. After the connector has been pressed on the cable, excess oxide inhibitor must be wiped from the connector and conductor surface.
 - C. Use special care to ensure a moisture-proof splice.
8. Table 9 on Page 14 shows solder-type connectors. These connectors must not be used on aluminum conductors. This type of connection is only allowed on paper insulated lead covered (PILC) cable.
9. If several insulated aluminum conductors are to be connected to one insulated copper conductor, each aluminum conductor must first be spliced to a short length of copper conductor so that the multiple connection can be made with all copper conductors. This multiple connection may be a tee tap (or several tee taps) as shown in [Document 051034](#).
10. Special care must be used to prevent moisture from entering through the copper strands when connecting a bare stranded copper conductor to an insulated aluminum conductor (e.g., copper-to-aluminum neutral connection). See Figure 1 below for these connections.

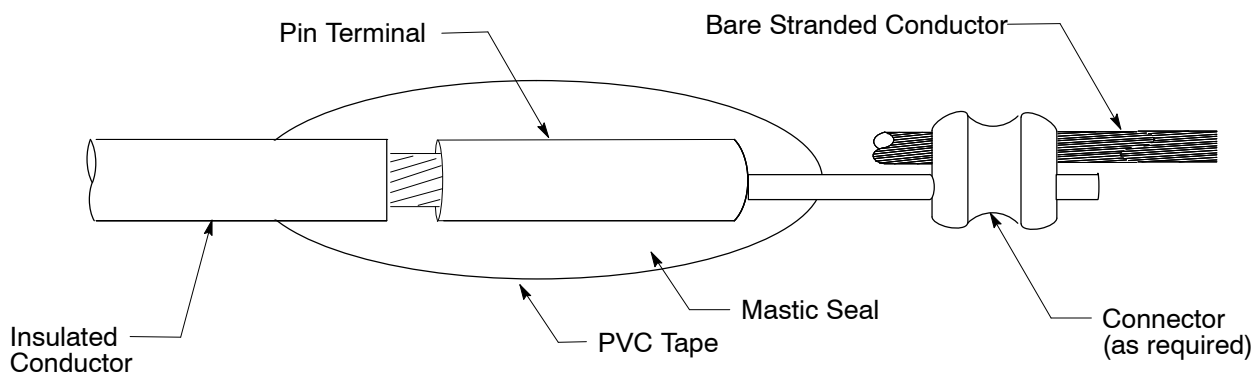
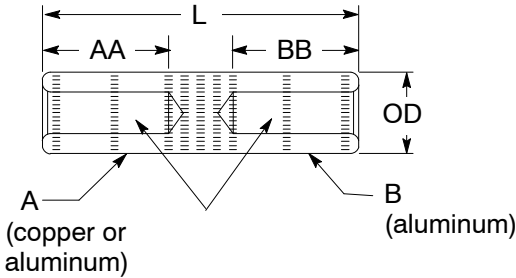

Figure 1
Connection Between Bare and Insulated Conductor

**Connectors for Insulated Cables
Underground Distribution Systems**

Straight Connectors Compression-Type (predrilled) Copper-to-Aluminum



**Figure 2
Overall Dimensions**

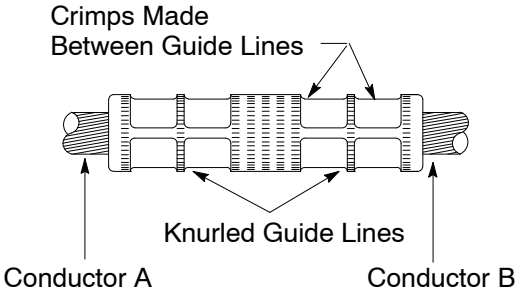

**Figure 3
View After Connector Installation
(for Figure 2)**

Table 5 Compression-Type Connectors – Predrilled

Conductor Size – AWG or kcmil		Connector Dimensions (inches)				Manufacturer and Catalog Numbers			6-Ton Tool Die # 5	Connector Code
A ¹ (Cu or Al)	B (Al)	AA	BB	L ²	OD	Burndy	Richards	Homac	12-Ton Tool Die # 15-Ton Tool Die #	
4	2	1.03	1.03	2.75	0.65	See Document 028852			W-BG U-BG U-BG ⁴	305558 ³
2	2					See Document 028852				305559 ³
2	1					YR1CA2CCAG ₁	ALCR 8-7	SAC1R2		305569
2	1/0					See Document 028852				305562 ³
2	2/0	1.56	1.56	4.00	0.91	YR26A2CCAG1	ALCR 10-7	SAC2/0 R2	W249 U249 U249 ⁴	305571
2/0	2/0					YS26UG2	ALC 10	SAC2/0		305581
2/0	3/0					YR27A26CAG1	ALCR 11-10	SAC3/0 R2/0		305582
2/0	4/0					YR28A26CAG1	ALCR 12-10	SAC4/0 R2/0		305585

¹ Maximum copper conductor size.
² These dimensions may vary slightly among the various suppliers.
³ These connectors are overhead-type insulated service sleeves. The insulation on these sleeves does not provide an adequate seal for underground application. These sleeves must be insulated and sealed as shown in [Document 051034](#) as if they were bare.
⁴ A U-die adapter must be used when utilizing U-dies in a 15-Ton press.
⁵ Within this column, the first entry corresponds to a 6-ton press tool, the second entry corresponds to a 12-ton press tool, and the third entry corresponds to a 15-ton press tool.

**Connectors for Insulated Cables
Underground Distribution Systems**

Straight Connectors Compression-Type (predrilled) Copper-to-Aluminum (continued)

Table 6 Compression-Type Connectors – Predrilled

Conductor Size – AWG or kcmil		Dimensions (inches)				Manufacturer and Catalog Numbers			6-Ton Tool-Die # 12-Ton Tool Die # 15-Ton Tool Die #	Connector Code
A ¹ (Cu or Al)	B (Al)	AA	BB	L ²	OD	Burdny	Richards	Homac		
250	250	1.86	1.86	4.62	1.12	YS29UG1	ALC 13	SACB250	– U31ART U31ART ³	305586
250	300					YR30A29CAG1	ALCR 14-13	SAC300R250		305602
250	350					YR31A29CA	ALCR 15-13	SAC350R250		305127
250	400	2.55	2.55	6.19	1.62	YR32A29CAG1	ALCR 16-13	SACL400R250	– – P39ART	305604
500/600	500					YS34APGE	ALC 18	SACL500		305108
500	600					YR36A34CA	ALCR 20-18	SAC600R500		305129
500	700, 750					YR39A34CA	ALCR 25-18	SAC750R500		305107
750	1,000					YR44AG3	ALCR 28-23	ATC1000R750		– – P44ART
For Circuits Above 5 kV										
4	2	1.50	1.50	3.57	0.65	YR2CA4CCATG1	OATCR7-5	SATC2R4	W-BG U-BG U-BG ³	305607
2	2					YS2CUTG1	OATC 7	SATC2		305608
2	1/0					YR25A2CCATG3	OATCR9-7	SATC1/0R2		305609
2/0	4/0	2.08	2.08	4.82	0.91	YR28A26CATG2	OATC 12-10	SATC4/0R2/0	W249 U249 U249 ³	305610
250	350	2.61	2.96	6.66	1.12	YR31A29CAT	OATC15-13	SAC350R250	– U31ART U31ART ³	305143
500/600	700, 750	3.75	4.19	9.41	1.62	YR39A34CAT	OATC23-18	ATC750R500	– – P39ART	305403
750	1,000	4.10	4.10	9.09	1.84	YR44ATG1	OATC28-13	ATC1000R750	– – P44ART	305611

¹ Maximum copper conductor size.

² These dimensions may vary slightly among the various suppliers.

³ A U-die adapter must be used when utilizing U-dies in a 15-Ton press tool.

⁴ Within this column, the first entry corresponds to a 6-ton press tool, the second entry corresponds to a 12-ton press tool, and the third entry corresponds to a 15-ton press tool.

Notes

1. Connectors must be pre-filled with an approved oxide inhibitor.
2. All connectors must have an oil stop.
3. The material for these connectors is bi-metal for use with aluminum to aluminum and aluminum to copper conductors.

**Connectors for Insulated Cables
Underground Distribution Systems**

Straight Connectors Compression-Type (aluminum-to-aluminum)

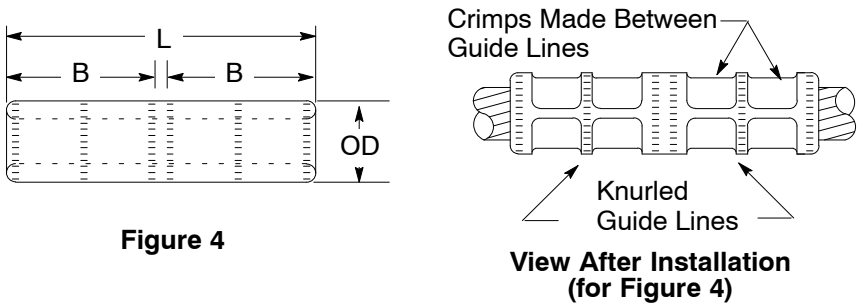

Figure 4

**View After Installation
(for Figure 4)**

Table 7 Dimensions and Ordering Information – Aluminum-to-Aluminum (Figure 4)

Conductor Size AWG or kcmil	Refer to	Dimensions (inches)			Manufacturer and Catalog Number			6-Ton Tool Die # ⁴ 12-Ton Tool Die # 15-Ton Tool Die #	Connector Code
		L	B	OD	Burndy	Richards	Homac		
2	Figure 5 On Page 12	2.75	1.18	0.65	See Document 028852			W-BG	305559 ¹
1/0		2.75	1.18	0.65				U-BG	305563 ¹
4/0		3.30 ²	1.54 ²	0.91	YS28AG9	ALC12	ASC4/0	W249 U249 U249 ³	305616
350		6.97	3.38	1.12	YS31AY	ALC15	AC350-HM	– U31ART U31ART ³	305148
700/750		8.28	4.00	1.62	YS39AY	ALC23	AC750	– – P39ART	305150
1,000	10.81	5.25	1.84	YS44AY	ALC28	AC1000	– – P44ART	305618	

¹ These connectors are overhead-type insulated service sleeves (see [Document 028852](#)). The insulation on these sleeves will not provide an adequate seal for underground application. These sleeves must be insulated and sealed as shown in [Document 051034](#) as if they were bare.

² For Burndy & Richards, Dimension L = 2.34", B = 1.09".

³ A U-die adapter must be used when utilizing u-dies with 15-Ton press.

⁴ Within this column, the first entry corresponds to a 6-ton press tool, the second entry corresponds to a 12-ton press tool, and the third entry corresponds to a 15-ton press tool

Notes

1. Connectors must be pre-filled with an oxide inhibitor.
2. Connectors shown in Table 7 above are not suitable substitutes for the compression connectors supplied in the 3M pre-molded splice kits. The connector ODs supplied in the splice kits are larger than normal to provide a heat sink and facilitate sliding the pre-molded housing back and forth.
3. These connectors are aluminum unplated finished and must be used only with aluminum cables.

Connectors for Insulated Cables Underground Distribution Systems

Straight Connectors Compression-Type (copper-to-copper)

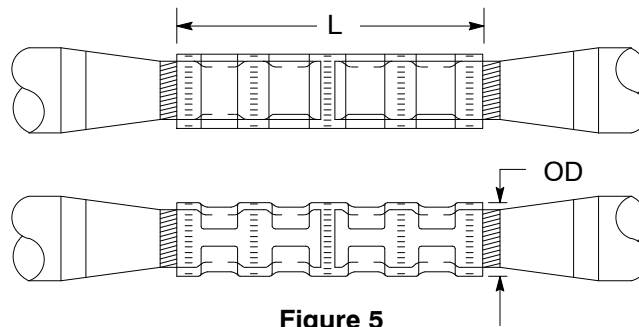

Figure 5

Table 8 Straight Connectors – Compression-Type – Copper-to-Copper (Figure 4)

Conductor Size AWG or kcmil	Dimensions (inches)		Manufacturer and Catalog Number				6-Ton Tool Die # ⁴ 12-Ton Tool Die # 15-Ton Tool Die #	Code
	Length (L)	OD	Burndy	Richards	Homac	Dossert		
4	2.38	0.34	YSP4CT	OCC5	PC-4-HM	DPCP 4	W4CRT U4CRT U4CRT ³	305164 ¹
2 ²	2.62	0.42	YSP2CT	OCC7	PC-2-HM	DPCP 6	W2CRT U2CRT U2CRT ³	305165 ¹
2/0	2.21	0.56	YS26T	CC10	TC-2/0	DPC 13-T	W26RT U26RT U26RT ³	305283
2/0	3.13	0.56	YSP26T	OCC10	PC-2/0	DPCP 13	U26RT ³	305167 ¹
4/0	2.39	0.69	YS28T	CC12	TC-4/0	DPC 21-T	W28RT U28RT U28RT ³	305285
250	3.38	0.75	YSP29T	OCC13	PC-250-HM	DPCP 25	– U29RT U29RT ³	305429 ¹
250	3.38	0.75	YS29	CC13	C-250-HM	DPC 25	U29RT ³	305202
500	4.62	1.06	YSP34T	OCC18	PC-500	DPCP 50	– U34RT U34RT ³	305428 ¹
500	4.63	1.06	YS34	CC18	C-500-HM	DPC 50	U34RT ³	305203
750	4.23	1.3	Y39T	CC23	TC-750-HM	DPC 75-T	– – P39RT	305488
1,000	6.13	1.50	YS44	CC28	C-1000	DPC 100	– – P44RT	305480
1,500	6.5	1.84	YS46	CC30	C-1500	DPC 150	– – P46RT	305511

¹ These connectors have oil stops. These are more costly connectors and should only be used for splicing P&L cable to rubber or polyethylene insulated cables.

² For #2 Solid, use Burndy 162 die index. Refer to Table 22 on Page 21 for Die ordering information.

³ A U-die adapter must be used when utilizing u-dies with 15-Ton press.

⁴ Within this column, the first entry corresponds to a 6-ton press tool, the second entry corresponds to a 12-ton press tool, and the third entry corresponds to a 15-ton press tool.

Connectors for Insulated Cables Underground Distribution Systems

Straight Connectors Compression-Type (copper-to-copper)(continued)

Notes

1. For material and finish information refer to “Specifications for Straight Compression Type Connectors for Insulated Copper Conductors”.
2. Connectors shown in Figure 5 on Page 12 are to be used to connect cables of up to 35 kV rating or lower, and can be used on bare cables where such cables will not be subjected to tension.
3. An indenter type compression die (clacker) should not be used on #4 or #2 AWG size connectors because it distorts the connector.
4. Round the sector cable with rounder tool.

**Connectors for Insulated Cables
Underground Distribution Systems**

Straight Connectors Solder-Type (copper-to-copper)

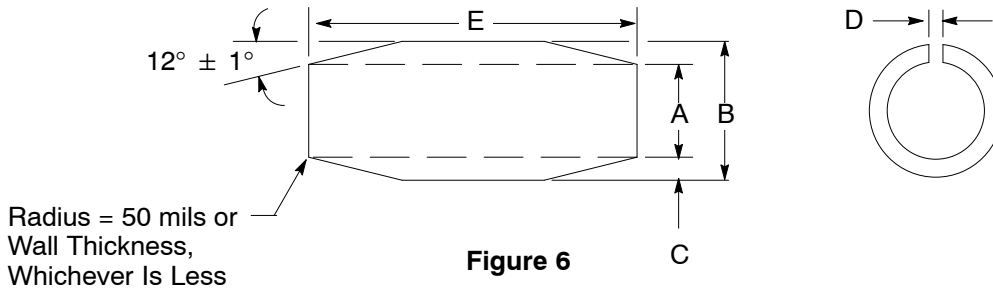

Table 9 Straight Connectors – Split Tinned-Type – Copper-to-Copper, All Voltages (Figure 6)

Cable Size AWG or Kcmil (round or compact sector)	Nominal Dimensions – Inches					Standard Package	Bumdy Part Number	Richards	Code
	A ID	B OD	C (wall thickness)	D (slot width)	E (length)				
8	5/32	3/16	1/32	1/32	1-1/2	200	SS8C8C	RSS2	305041
6	3/16	1/4	1/32	1/32	1-1/2	200	SS6C6C	RSS3	305042
4	7/32	5/16	1/32	1/32	2	100	SS4C4C	RSS5	305043
2	9/32	3/8	1/32	1/32	2	100	SS2C2C	RSS7	305044
1/0	3/8	1/2	1/16	1/16	2	100	SS2525	RSS9	305045
2/0	13/32	9/16	1/16	1/16	2	100	SS2626	RSS10	305046
3/0	15/32	5/8	1/16	1/16	2	100	SS2727	RSS11	305059
4/0	17/32	23/32	1/16	1/16	2-1/2	50	SS2828	RSS12	305047
250	9/16	25/32	3/32	1/8	2-1/2	50	SS2929	RSS13	305048
350	11/16	29/32	3/32	1/8	2-1/2	20	SS3131	RSS15	305324
400	23/32	31/32	1/8	1/8	3	10	SS3232	RSS16	305049
500	13/16	1-3/32	1/8	1/8	3	10	SS3434	RSS18	305050
600	29/32	1-3/16	1/8	5/32	3-1/2	10	SS3636	RSS20	305051
750	1-1/32	1-11/32	5/32	5/32	3-1/2	10	SS3939	RSS23	305052
1,000	1-5/32	1-9/16	3/16	7/32	4-1/2	1	SS4444	RSS28	305053
1,500	1-7/16	1-29/32	7/32	9/32	5	1	SS4646	RSS30	305054
2,000	1-21/32	2-7/32	1/4	9/32	6	1	SS4848	RSS32	305055

Notes

- For material and finish refer to “Edison Electric Institute Specification TD 160 “Specifications for Solder-Sweated Split Tinned Copper Connectors”.
- When splicing cables of different sizes, cut a sector from one half of the connector.
- When tinning and sweating the connector onto the conductors:
 - Protect the insulation.
 - Wipe smooth, removing all sharp solder points.
- Round the sector cable with a rounder tool.

Application

These connectors must be used only to tap splices 5,000 V and above on copper PILC cable in sizes larger than #2 AWG.

**Connectors for Insulated Cables
Underground Distribution Systems**

Bolted Connectors for Underground Network Systems

A. These copper alloy connectors are for making copper-to-copper current carrying connections on underground network secondary systems in San Francisco and Oakland.

Table 10 Split Bolt Connectors For Copper-to-Copper Connections (Figure 7)

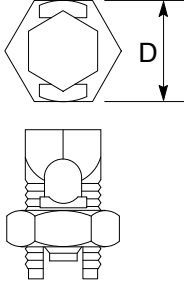

Figure 7

Conductor Size AWG or kcmil		Nut Size D	Torque Inch-lbs. (ft./ lbs)	Code	Manufacturer and Catalog Number			
Solid	Stranded				Blackburn	Burndy	Penn-Union	Homac
10	10	7/16"	80 (7)	305026	9H	KS90	S-10-S	-
8	8	1/2"	80 (7)	305027	8H	KS15	S-8-S	E-8
6	8	11/16"	-	305028	6H	KS17	S-6-PGE	E-6
4	6	3/4"	-	305029	4H	KS20	S-4-PGE	E-4
2	4	7/8"	-	305030	2H	KS22	S-3-PGE	E-2
1	2	7/8"	-	305031	1H	KS23	S-2-S	-
2/0	1/0	1"	-	305032	10H	KS25	S-1/0-S	E-1/0
3/0	2/0	1-1/18"	385 (32)	305033	20H	KS26	S-2/0-S	E-2/0
4/0	3/0, 4/0, 250	1-5/16"	650 (54)	305034	40H	KS29	S-250-PGE	E-250

Table 11 Two Bolt Connectors for Copper-to-Copper Connections (Figure 8)

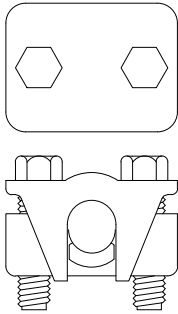

Figure 8

Conductor Size AWG or kcmil		Code	Manufacturer and Catalog Number					
Main Run	Min. Tap		Hubbell	Blackburn	Burndy	Penn-Union	AFL	Homac
4/0	6	305431	K-3	2B40	KVS28	VT-2	DSU21	-
250 to 350	1/0	305432	K-4	2B350	KVS31	VT-3	DSU35	TBC 350
400 to 500	2/0	305433	K-5	2B500	KVS34	VT-4	DSU50	TBC 500
600 to 750	4/0	305434	K-6	2B800	KVS40	VT-5	DSU80	TBC 800
800 to 1,000	4/0	305435	K-7	2B1000	KVS44	VT-6	DSU1000	TBC 1000

Notes

1. Connectors shown in Table 10 and Table 11 are for use on unshielded insulated cables rated 600 V or lower.
2. Connectors shown in Table 10 may also be used to connect unshielded streetlighting cable.
3. If necessary, double back on small size tap wires to obtain a tight fit.
4. The connectors described on this page can be used on bare cables where such cables will not be subjected to tension.
5. These connectors shall not be used in overhead applications.

Ground Terminal

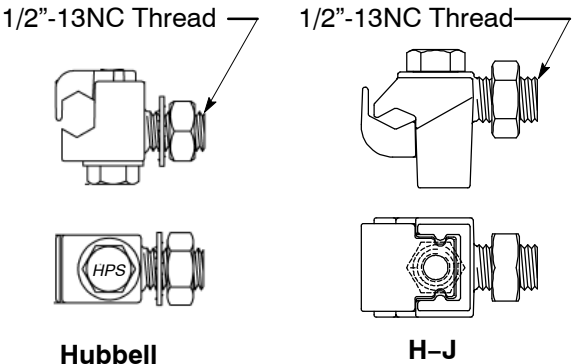

Figure 9

Table 12 Ground Terminal (Figure 9) ^{1,2}

Conductor Size AWG	Manufacturer and Catalog Number		Code
#4 Str. - 2/0	Hubbell	GC-208	M301546
#4 Solid - 2/0	H - J	AS1372-002	M301655

- 1 Use H-J vise-type ground terminal lug to ground OH and UG equipment.
- 2 Use Hubbell vise-type ground terminal lug **only** to ground UG equipment. Do not use Hubbell vise-type ground terminal to ground OH equipment.

**Connectors for Insulated Cables
Underground Distribution Systems**

Tap Connectors Compression-Type (#6 through 397.5 kcmil aluminum-to-aluminum or aluminum-to-copper)

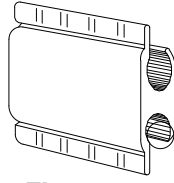

**Figure 10
H-Type Connector**

Table 13 Tap Connectors - Compression-Type - Aluminum-to-Aluminum or Aluminum-to-Copper (Figure 10) ¹

Conductor Size AWG or kcmil		Tap																
Conductor Size AWG or kcmil		#6 Sol.	#4 Sol.	#4 Str.	#2 Sol.	#1 Sol.	#2 Str.	1/0 Sol.	1/0 Str.	2/0 Str.	3/0 Str.	4/0 Str.	250	266.8 Str.	336.4 Str.	350	397.5	
Run	#6 Sol.	Code 305507				-		-		-		-		-				
	#4 Sol.	Code 305507				-		-		-		-		-				
	#4 Str.	Code 305507				-		-		-		-		-				
	#2 Sol.	Code 305509				-		-		-		-		-				
	#1 Sol.	Code 305509				-		-		-		-		-				
	#2 Str.	Code 305509				-		-		-		-		-				
	1/0 Sol.	Code 305509				-		-		-		-		-				
	1/0 Str.	Code 305510				-		-		Code 305519		-		-				
	2/0 Str.	Code 305510				-		-		Code 305519		Code 305831		-				
	3/0 Str.	Code 305520				-		-		Code 305830		Code 305831		-				
	4/0 Str.	Code 305520				-		-		Code 305830		Code 305831		-				
	250	-				-		-		-		-		-				
	266.8 Str.	-				-		-		-		Code 305833		Code M305834				
	336.4 Str.	Code 305832				-		-		-		Code 305833		Code M305834				
350	Code 305832				-		-		-		Code 305833		Code M305834					
397.5	Code 305832				-		-		-		Code 305833		Code M305834					

¹ For required number of compressions, Refer to Table 15 on Page 17.

Table 14 Aluminum Compression Connectors for Secondary Connections to Streetlight Conductors

Conductor Size (AWG)		Tap	
		#10 Sol.	#8 Sol.
Run	#2 Str.	Code 305842	
	1/0 Str.	Code 305842	
	2/0 Str.	Code 305842	
	3/0 Str.	Code 305843	
	4/0 Str.	Code 305843	

**Connectors for Insulated Cables
Underground Distribution Systems**

Tap Connectors Compression-Type (#6 through 397.5 kcmil aluminum-to-aluminum or aluminum-to-copper) (continued)

Note

The material for these connectors is bi-metal for use with aluminum to aluminum and aluminum to copper conductors.

Application

These connectors are used for straight splice or tap, residential and light commercial.

Table 15 Aluminum H-Type Compression Connectors

Tools and Dies Data				
Connector Code 1	6-Ton Tool		12-Ton Tool	
	Die	Required # of Compressions	Die	Required # of Compressions
305507	W-O	4	U-O	2
305509		5 ¹		
305510	W-D	5 ¹	U-D	2
305519				
305520				
305830				
305831		7		3
305832	-	-	U-N	2
305833				3
305834				
Connectors for Connection to Secondary Streetlight Conductors				
305842	W-O	4	U-O	2
305843	W-D	4	-	-

¹ These connectors are the same tap connectors shown in [Document 041010](#).

Note

1. Do not use the N Die with UT-15 tools
2. Use U-die adapter with U-dies when a 15-ton press tool is utilized.

Connectors for Insulated Cables Underground Distribution Systems

Tap Connectors Compression-Type for Secondary Conductors (2/0 through 1000 kcmil aluminum-to-aluminum or aluminum-to-copper)

Table 16 Tap Connectors – Compression-Type for Secondary Conductors

Conductor Size AWG or kcmil	Tap														
	2/0	3/0	4/0	250	268.8	300	397.5	500	600	636	700	715.5	750	900	1000
Run	397.5	Code 305833			Code 305834			Code 305522			-				
	500	Code 305521						Code 305522			-				
	600	Code 305521						Code 305522			-				
	636	Code 305524						Code 305526			Code 305537				
	700	Code 305524						Code 305526			Code 305537				
	715.5	Code 305524						Code 305526			Code 305537				
	750	Code 305524						Code 305526			Code 305537				
	900	Code 305524						Code 305526			Code 305537				
1,000	Code 305804			Code 305875			Code 305976					Code 305538			

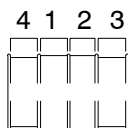

Marking on Connector for Compression with R Die

Figure 11

Order of Compression Sequence for R Die



Position of Z Die on R Die Compression Markings

Figure 12

Order of Compression Sequence for Z Die

Table 17 Ordering Data for Z Die for Use in UT-15 Hydraulic Tool

Die Designation	Code	Manufacturer and Catalog Number
Z	216248	Homac 15 CZ
P-KR	216263	Burndy



Figure 13
Homac 15 CZ Die



Figure 14
Burndy PKR Die

Notes

1. The material for these connectors is bi-metal for use with aluminum to aluminum and aluminum to copper conductors.
2. Use dies in Table 17 to press connectors in Table 16.
3. The head for the Homac 15 CZ die is the UT-15 hydraulic.
4. Use a 15-ton battery powered press with Burndy PKR die.

Application

These connectors are used for straight splice or tap, residential and light commercial.

**Connectors for Insulated Cables
Underground Distribution Systems**

Tap Connectors Compression-Type for Secondary Conductors (copper-to-copper)

Table 18 YP-C-Tap (Figure-6 Type) (Figure 15) Copper Connectors



**Figure 15
Burndy YP-C-Tap Type**

Conductor Size AWG or kcmil		Tap										
		#6 Sol.	#4 Sol.	#4 Str.	#2 Sol.	#1 Sol.	#2 Str.	1/0 Sol.	1/0 Str.	2/0 Str.	3/0 Str.	4/0 Str.
Run	#6 Sol.	Code 305844					-			Code 012086		
	#4 Sol.											
	#4 Str.											
	#2 Sol.											
	#1 Sol.											
	#2 Str.											
	1/0 Sol.	Code 305845					-					
	1/0 Str.											
	2/0 Str.											
	3/0 Str.											
4/0 Str.												
250	-											

Table 19 Die Information for YP-C (Figure-6 Type) Connectors (Figure 15)

Manufacture and Catalog Numbers		Die ^{1, 2}	Connector Code	Required Number of Compressions
Brundy	Dossert	Die		
YP2C2	DC6	U-O	305844	1
YP29C26	DC25-13	U-D3	305845	1
YP28C28	-	U-D3	012086	1

¹ These dies use a 12-ton press tool.

² Refer to Table 23 on Page 21 for Die ordering information.

Connectors for Insulated Cables Underground Distribution Systems

Tap Connectors Compression Type for Secondary Conductors (copper-to-copper) (continued)



Figure 16
Blackburn, Kearney,
Homac, Penn-Union
H-Tap Type

**Table 20 Blackburn, Homac, Kearney and Penn-Union H-Tap
Copper Connectors (Figure 16)**

Conductor Size AWG or kcmil		Tap										
		#6 Sol.	#4 Sol.	#4 Str.	#2 Sol.	#1 Sol.	#2 Str.	1/0 Sol.	1/0 Str.	2/0 Str.	3/0 Str.	4/0 Str.
Run	#6 Sol.	Code 305243										
	#4 Sol.											
	#4 Str.	Code 305244			-							
	#2 Sol.											
	#1 Sol.											
	#2 Str.	Code 305245						Code 305246				
	1/0 Sol.											
	1/0 Str.											
	2/0 Str.									Code 305249		Code 305846
	3/0 Str.	-		Code 3052147 ¹								
4/0 Str.												

¹ Only the Kearney connector is currently approved for use with #6 solid using a U-D die

Table 21 Blackburn, Kearney, and Penn-Union Connectors

Connector Code	Blackburn Part No.	Kearney Part No.	6-Ton Tool		12-Ton Tool	
			Die	Required Number of Compressions	Die	Required Number of Compressions
305243 ¹	CF-44-1	301-82	W-KB	3	-	-
305244 ¹	CF-22-1	302-82	W-KK	3	-	-
305245	CF-102-1	304-82	-	-	U-O	1
305246	CF-1010-1	303-82	-	-	U-O	1
305247 ¹	CF-402-1	309-82	-	-	U-D	1
305249	CF-4010-1	308-82	-	-	U-D, D3	1
305846	CF-4040-1	307-82	-	-	U-D, D3	1

¹ Do not use W-BG die for M305243 and M305244 codes.

² Only the Kearney connector is approved for use with #6 solid using a U-D die.

**Connectors for Insulated Cables
Underground Distribution Systems**

Table 22 Die Ordering Data for 6-Ton Press Tool

Burndy Catalog Number	Die Code ^{1, 2}	Burndy Catalog Number	Die Code ^{1, 2}
W-BG	202848	W-164	200917
W-KB	202240	W-165	200918
W-KK	202241	W-166	200919
W-O	200925	W-167	2713954
W-4CRT	210229	W-243	202673
W-25RT	210230	W-245	200921
W-28K	210228	W-247	200922
W-31ART	206041	W-4CRT	210229
W-161	200915	W-249	203039
W-162	200916	W-687	2649576
W-163	203038	W-K840	210598

¹ Code includes one complete set of dies consisting of two half-sections.

² These dies are only available for purchase in MRO integrated solution catalog via Ariba. The codes shown on this table are the PG&E part number.

Notes

The material for connectors shown on Pages 19 and 20 is copper alloy.

Application

Connectors shown on Pages 19 and 20 are used for straight splice or tap.

Table 23 Dies Ordering Data for 12-Ton Press Tool

Burndy Catalog Number	Die Code ^{1, 2}	Burndy Catalog Number	Die Code ^{1, 2}
U-BG	216272	U-31ART	216130
U-O	216083	U-32ART	216068
U-D	2811758	U-34RT	216166
U-D3	216084	U-34ART	216069
U-N	216085	U-36RT	2603893
U-BKT	216133	U-36ART	216247
U-2CABT	216063	U-39RT	26706
U-25RT	216276	U-164	216582
U-25ART	216064	U-165/U205	210596
U-26RT	216164	U-166/U459	216583
U-26ART	216065	U-167/U568	210597
U-27RT	216277	U-168	216584
U-27ART	216262	U-169	216585
U-28RT	216278	U-243	216566
U-28ART	216066	U-247	210622
U-29RT	216165	U-248	216569
U-29ART	216067	U-249	216273
U-30RT	216279	U-251	216081
U-30ART	236866	U-321	210623
U-31RT	216280	U-468	210624

¹ Code includes one complete set of dies consisting of two half-sections.

² These dies are only available for purchase in MRO integrated solution catalog via Ariba. The codes shown on this table are the PG&E part number.

**Connectors for Insulated Cables
Underground Distribution Systems**

Table 23 Dies Ordering Data for 12-Ton Press Tool (continued)

Burndy Catalog Number	Die Code ^{1, 2}	Burndy Catalog Number	Die Code ^{1, 2}
U-39ART2	210600	U-654	210625
U-161	2791549	U-690	216556
U-163	2755406	U-1011	2688161
U-608	2724024		

¹ Code includes one complete set of dies consisting of two half-sections.

² These dies are only available for purchase in MRO integrated solution catalog via Ariba. The codes shown on this table are the PG&E part number.

Table 24 Dies Ordering Data for 15-Ton Press Tool

Burndy Catalog Number	Die Code ^{1, 2}
P-KR	216263
P39ART	216578
P39RT	216580
P44ART	216579
P44RT	216581
P724RT	216264

¹ Code includes one complete set of dies consisting of two half-sections.

² These dies are only available for purchase in MRO integrated solution catalog via Ariba. The codes shown on this table are the PG&E part number.

**Connectors for Insulated Cables
Underground Distribution Systems**

Connectors for Splicing and Tapping Concentric Wires and Flat Straps

Table 25 For Splicing and Tapping of XLP-Conc-PVC Cable Concentric Wires ²

Primary Cable Size AWG or kcmil Document 039955 ¹	2/0 Cu 1/0 Al 4/0 Al	350 Al	#2 Al	#4 Cu 250 Cu	#2 Cu	700 Al	500 Cu	1,000 Al
Conc. Size	8 - #14	9 - #14	10 - #14	11 - #14	17 - #14	18 - #14	13 - #12	16 - #12
2/0 Cu 1/0 Al 4/0 Al	8 - #14	Code 305244		Code 305245				Code 305245
350 Al	9 - #14							
#2 Al	10 - #14							
#4 Cu 250 Cu	11 - #14	Code 305245		Code 304526				
#2 Cu	17 - #14							
700 Al	18 - #14							
500 Cu	13 - #12							
1,000 Al	16 - #12	Code 305245						
-	#2 Str. Cu	Code 305244		Code 305245				
-	#2 Solid Cu	Code 305244		Code 305245				

¹ For extension or splicing out of concentric neutral wires, see [Document 051071](#). or [Document 066204](#).

² This cable design is no longer approved for purchase.

Table 26 Connectors for Splicing and Tapping EPR Cable Concentric Wires ¹

Primary Cable Size AWG or kcmil Document 039955 ²	#2 1/0 600	Concentric Size (AWG)	10-#14	12-#14
		10-#14	Code 305244	Code 305245
1,100 (Al)		12-#14	Code 305245	Code 305246
1,100 (Cu)		14-#12		Code 305246

¹ This cable design is our current standard.

² For extension or splicing out of concentric neutral wires, see [Document 051071](#) or [Document 066204](#)

Table 27 Connectors for Splicing and Tapping EPR-Cable Flat Straps ¹

Primary Cable Size AWG or kcmil Document 039955 ² (Cu)	Flat Straps Size (mils x mils)= (AWG)	#2	350 500	750	1,100
		8 - 175X20 = #4	10 - 175X20 = #4	16 - 175X20 = #2	18 - 215X25 = 1/0
#2	8 - 175X20 = #4	Code 305507		Code 305509	-
350 500	10 - 175X20 = #4				
700	16 - 175X20 = #2	Code 305509			Code 305509
1,100	18 - 215X25 = 1/0				Code 305519

¹ This cable design is used in special application.

² For extension or splicing out of concentric wires, see [Document 051071](#). or [Document 076264](#).

**Connectors for Insulated Cables
Underground Distribution Systems**

Connectors for Splicing and Tapping Concentric Wires and Flat Straps (continued)

Table 28 Equivalent Conductor Size for Concentric Wires ¹

Equivalent Size	Concentric Size
<p align="center">#4 Approximate</p>	8 – #14
	9 – #14
	10 – #14
<p align="center">#2 Approximate</p>	11 – #14
	12 – #14
	17 – #14
<p align="center">1/0 Approximate</p>	18 – #14
	13 – #12
	14 – #12
	16 – #12

¹ To connect these concentric wires to conductors other than #2, use the equivalent conductor size and select a connector from Table 18 and Table 20 on Page 19 and Page 20 accordingly.

**Connectors for Insulated Cables
Underground Distribution Systems**

**Terminal Connectors Compression-Type
(aluminum cable for flat bar or transformer spade terminals)**

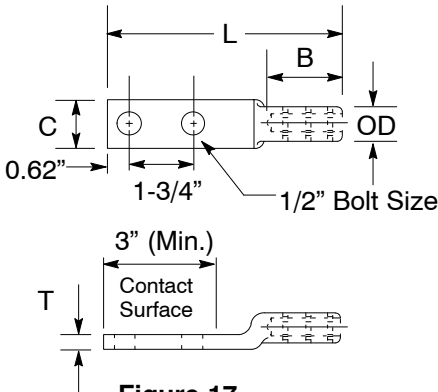

**Figure 17
Straight Terminal**

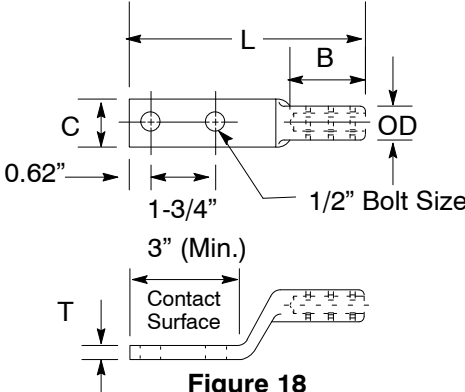

**Figure 18
Stacking Terminal**

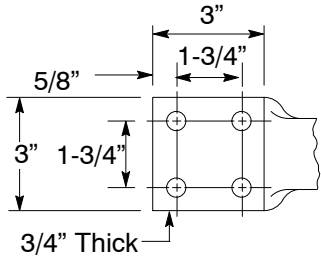

**Figure 19
4-Hole Pad**

Table 29 Specifications for Terminal Connectors – Aluminum Cable to Flat Bar (Figure 17 and Figure 18)

Cable Size AWG or kcmil	Refer to	Approved for Purchase					Connector Code	6-Ton Tool Dies # ⁷ 12-Ton Tool Dies # 15-Ton Tool Dies #
		Approximate Dimensions (inches)						
		B	C ¹	L ¹	T ¹	OD		
4	Figure 17	1.24	1.25	4.92	0.25	0.65	303829	W-BG U-BG U-BG ⁸
2		1.10	0.91	5.62	0.25	0.65	303761	
1/0		1.10	0.91	5.62	0.25	0.65	303760	
2/0		1.60	1.25	5.43	0.25	0.91	303830	– U26ART U26ART ⁸
4/0		1.60	1.25	5.75	0.30	0.91	303759	– U28ART U28ART ⁸
250		1.96	1.25	5.88	0.25	1.12	303831	– U249ART U249ART ⁸
350		1.91	1.62	6.84	0.38	1.12	303758	– U31ART U31ART ⁸
500/600		2.62	1.62	6.78	0.38	1.62	303832	– U34ART U34ART ⁸
700/750 ²		2.65	1.62	8.22	0.62	1.62	303833	– – P39ART
1,000/1,100 ²		2.97	1.62	8.88	0.62	1.84	303834	– – P44ART
1,250 ³		2.58	2.60	7.53	0.51	1.84	303835	L727 ⁶
1,500 ³		3.19	3.09	8.59	0.81	2.26	303836	L46ART ⁶
1,750 ³		3.69	3.33	8.38	0.86	2.46	303837	L735 or L735W ⁶
2,000 ³		3.69	3.57	8.50	0.94	2.60	303838	L48ART ⁶

**Connectors for Insulated Cables
Underground Distribution Systems**

***Terminal Connectors Compression-Type
(aluminum cable to flat bar or transformer spade terminals) (continued)***

**Table 29 Specifications for Terminal Connectors – Aluminum Cable to Flat Bar (Figure 17 and Figure 18)
(Continued)**

Cable Size AWG or kcmil	Refer to	Approved for Purchase					Connector Code	6-Ton Tool Dies # ⁷ 12-Ton Tool Dies # 15-Ton Tool Dies #
		Approximate Dimensions (inches)						
		B	C ¹	L ¹	T ¹	OD		
6 ⁵	Figure 18 ^{4, 5} (stacking terminals)	1.50	0.87	5.25	0.21	0.62	303732	W-BG U-BG U-BG ⁸
2 ⁵		1.10	0.91	5.62	0.25	0.65	303731	
1/0 ⁵		1.10	0.91	5.62	0.25	0.65	303730	
4/0 ⁵		1.52	1.17	6.20	0.30	0.91	303729	– U28ART U28ART ⁸
250		1.90	1.62	6.6	0.38	1.0	301283	– U249ART U249ART ⁸
350 ⁵		2.25	1.62	6.84	0.38	1.12	303728	– U31ART U31ART ⁸
700/750 ^{2, 5}		2.65	1.62	8.22	0.62	1.62	303839	– – P39ART
1,000/1,100 ^{2, 5}		2.97	1.62	8.88	0.62	1.84	303840	– – P44ART

¹ These dimensions may vary slightly among the various suppliers.

² These connectors shall be designed to fit side by side on a standard NEMA spade terminal (see Figure 26 on Page 32).

³ To order 4-hole terminals larger than 1,000 kcmil, select the Burndy or Homac terminal for the proper cable size and substitute 4 for 2 in the catalog number. Example: YA45A-4NTN or Homac AL-750-4NTN. See Figure 19 on Page 25.

⁴ If it is necessary to stack copper conductors, use aluminum stacking connectors.

⁵ These connectors shall be capable of being stacked on any straight terminal of equal or larger size (up to and including 1,000 kcmil).

⁶ These Die require a 60-ton press tool.

⁷ Within this column, the first entry corresponds to a 6-ton press tool, the second entry corresponds to a 12-ton press tool, and the third entry corresponds to a 15-ton press tool.

⁸ A U-die adapter must be used when utilizing U-dies in a 15-Ton press.

**Connectors for Insulated Cables
Underground Distribution Systems**

**Terminal Connectors Compression-Type
(aluminum cable to flat bar or transformer spade terminals) (continued)**

Table 30 Terminal Connectors (aluminum cable to flat bar)

Cable Size AWG or kcmil	Approved for Purchase		
	Manufacturer and Catalog Number		Connector Code
	Homac	Burndy	
4	SA4NTN	YAR4U2NTN	303829
2	SA2NTN	YAR2U2NTN	303761
1/0	AL1/0-NTN	YAK25A-2GA	303760
2/0	SA2/0-NTN	YAR2/0U2NTN	303830
4/0	AL4/0-NTN	YA4/0A2NTN	303759
250	SAB4/0-NTN	YA250A2NTN	303831
350	AL350-NTN	YA350A2NTN	303758
500	SAL500-NTN	YA500A2NTN	303832
700/750 ¹	AL750-NTN	YA750A2NTN	303833
1,000/1,100 ¹	AL1000-NMS	YA1000A2NTN	303834
1,250 ²	AL1250-NTN	YA1250A2NTN	303835
1,500 ²	AL1500-NTN	YA1500A2NTN	303836
1,750 ²	AL1750-NTN	YA1750A2NTN	303837
2,000 ²	AL2000-NTN	YA2000A2NTN	303838
Stacking Terminal			
6 ^{3, 4}	SASL 6-NTN	YARSO6U2NTN	303732
2 ^{3, 4}	ASL 2-NTN	YARSO2U2NTN	303731
1/0 ^{3, 4}	ASL1/0-NTN	YARSO1/0U2NTN	303730
4/0 ^{3, 4}	ASL4/0-NTN	YASO4/0A2NTN	303729
250	ASL250-NTN	YASO250A2NTN	301283
350 ^{3, 4}	ASL350-NTN	YASO350A2NTN	303728
700/750 ^{1, 3, 4}	ASL750-NTN	YASO750A2NTN	303839
1,000/1,100 ^{1, 3, 4}	ASL1000-SSNTN	YASO1000A2NTN	303840

- ¹ These connectors shall be designed to fit side by side on a standard NEMA spade terminal (see Page 30).
² To order 4-hole terminals larger than 1,000 kcmil, select the Burndy or Homac terminal for the proper cable size and substitute 4 for 2 in the catalog number. Example: YA45A-4NTN or Homac AL-750-4NTN.
³ If it is necessary to stack copper conductors, use aluminum stacking connectors.
⁴ These connectors shall be capable of being stacked on any straight terminal of equal or larger size (up to and including 1,000 kcmil).

Notes

1. The material for these connectors, is tinned aluminum alloy, tubular.
2. Attach terminal connectors using Everdur bolts and washers shown on page 31. For ordering Everdur Bolts refer to Table 32 on Page 31.
3. Partially filled with oxide inhibitor and sealed. For ordering Everdur bolts refer to Table 33 on Page 31.
4. Connections of copper-to-copper, tinned aluminum-to-copper, and tinned aluminum-to-tinned aluminum require no special precautions other than a clean surface. Any combination involving an untinned aluminum surface requires the application of oxide inhibitor to the surface. Wire brush the surface through the compound thoroughly. Brushing through this inhibitor prevents the oxide from reforming. If in doubt as to the materials or tinning, applying inhibitor will do no harm

**Connectors for Insulated Cables
Underground Distribution Systems**

**Terminal Connectors Compression-Type
(copper cable to flat bar or transformer spade terminals) (continued)**

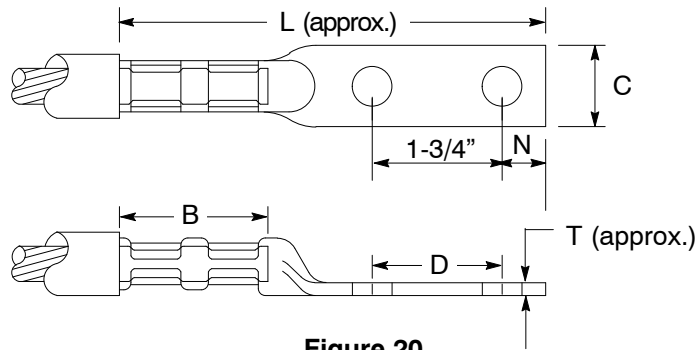

Figure 20

Table 31 Specifications for Terminal Connectors – Copper Cable to Flat Bar (Figure 20)

Cable Size AWG or kcmil	Manufacture and Catalog Number		Approved for Purchase							Bolt Size	Connector Code	6-Ton Tool Dies # ¹ 12-Ton Tool Dies # 15-Ton Tool Dies #
			Dimensions (inches)									
			B	C	D	L	N	T				
4 ⁵	L4N	YA4C-2N	1-1/8	13/16	3	4-1/2	5/8	1/8	1/2	303916	W4CRT ² U4CRT ² U4CRT ^{2,6}	
2 ^{2,5}	L2N	YA2C-2N	1-1/4	13/16	3	4-23/32	5/8	1/8	1/2	303221	W2CRT U2CRT U2CRT ⁶	
1 ⁵	L1N	YA1C-2N	1-3/8	13/16	3	4-7/8	5/8	1/8	1/2	303804	W1CRT1 U1CRT1 U1CRT1 ⁶	
1/0 ⁵	L1/0N	YA25-2N	1-3/8	13/16	3	4-29/32	5/8	1/8	1/2	303209	W25RT U25RT U25RT ⁶	
2/0 ⁵	L2/0N	YA26-2N	1-1/2	13/16	3	4-29/32	5/8	1/8	1/2	303220	W26RT U26RT U26RT ⁶	
3/0 ⁵	L3/0N	YA27-2N	1-1/2	29/32	3	4-15/16	5/8	1/8	1/2	303219	W27RT U27RT U27RT ⁶	
4/0 ⁵	L4/0N	YA28-2N	1-5/8	1	3	5-1/16	5/8	9/64	1/2	303917	– U28RT U28RT ⁶	
250 ⁵	L250-N	YA29-2N	1-5/8	1-3/32	3	5-5/32	5/8	5/32	1/2	303092	– U29RT U29RT ⁶	
300	L300-N	YA30-2N	2	1-11/16	3	5-3/4	5/8	5/32	1/2	303451	– U30RT U30RT ⁶	
350 ⁵	L350-N	YA31-2N	2	1-25/32	3	5-11/16	5/8	3/16	1/2	303452	– U31RT U31RT ⁶	
500 ⁵	L500-N	YA34-2N	2-1/4	1-17/32	3	5-15/16	5/8	15/64	1/2	303093	– U34RT U34RT ⁶	

**Connectors for Insulated Cables
Underground Distribution Systems**

**Terminal Connectors Compression-Type
(copper cable to flat bar or transformer spade terminals)**

**Table 31 Specifications for Terminal Connectors – Copper Cable to Flat Bar (Figure 20 on Page 28)
(Continued)**

Cable Size AWG or kcmil	Manufacture and Catalog Number		Approved for Purchase							Bolt Size	Connector Code	6-Ton Tool Dies # ¹ 12-Ton Tool Dies # 15-Ton Tool Dies #
			Dimensions (inches)									
			B	C	D	L	N	T				
600 ^{3, 4}	L600-N	YA36-2N	2-11/16	1-1/2	3	6-5/8	5/8	17/64	1/2	303454	- U36RT U36RT ⁶	
750 ^{3, 4, 5}	L750-N	YA39-2NN1	2-7/8	1-3/4	3	6-3/4	5/8	17/64	1/2	303296	- - P39RT	
1,000/ 1,100 ^{3, 5}	L1000N	YA44-2NG10	3	1-3/4	3	6-15/16	5/8	21/64	1/2	303461	- - P44RT	

¹ Within this column, the first entry corresponds to a 6-ton press tool, the second entry corresponds to a 12-ton press tool, and the third entry corresponds to a 15-ton press tool

² For #2 Solid, use Burndy 162 die index. For Die ordering information refer to Table 22 on Page 21

³ Dimension C shall not exceed 1-3/4".

⁴ To order 4-hole terminals, select the Homac or Burndy terminal for the proper cable size and substitute 4 for 2 in the catalog number. For example: YA39-4NNT, for Burndy L750-4N for Homac.

⁵ Conductor can be compressed or compact.

⁶ A U-die adapter must be used when utilizing U-dies in a 15-Ton press.

Notes

1. Attach using Everdur bolts and washers as shown on Table 33 on Page 31.
2. Connections of copper-to-copper, tinned aluminum-to-copper, and tinned aluminum-to-tinned aluminum pads require no special precautions other than a clean surface. Any combination involving an untinned aluminum surface requires the application of oxide inhibitor to the surface. Wire brush the surface through the compound thoroughly. Brushing through this inhibitor prevents the oxide from reforming. If in doubt as to the materials or tinning, application of the inhibitor will do no harm.

Applications of Compression-Type Terminal Connectors

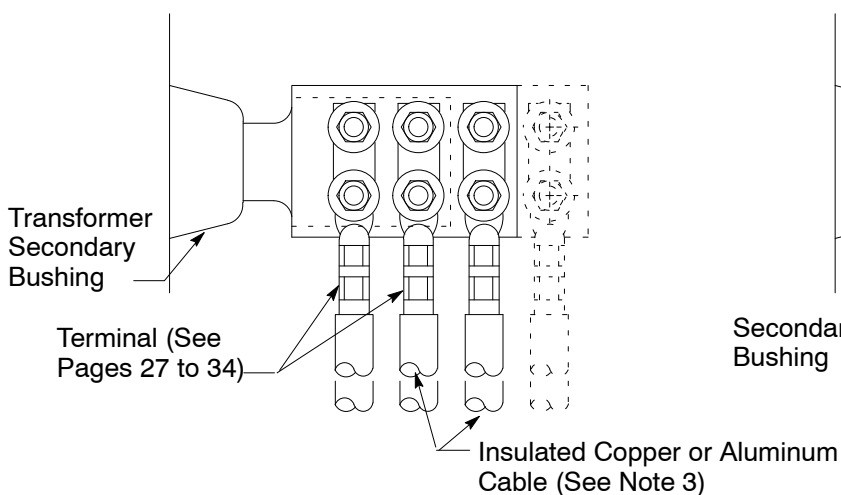
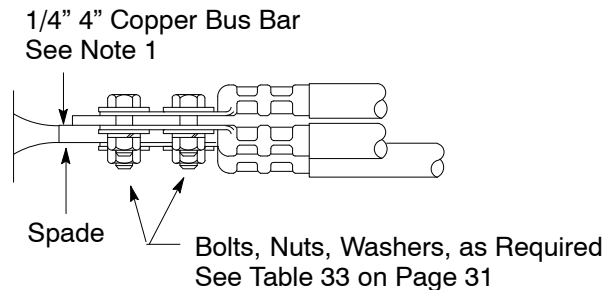
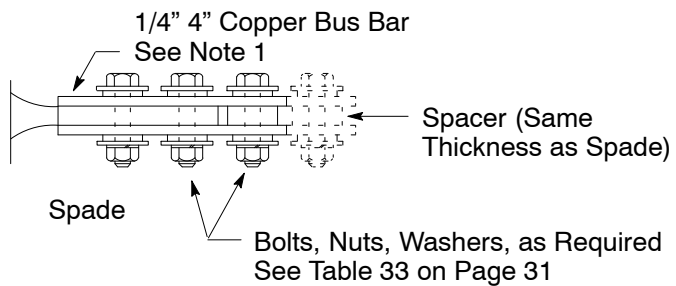

Figure 21

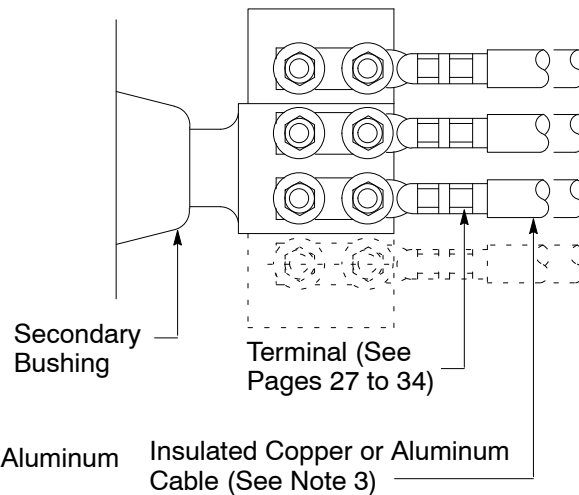

Figure 22

Notes

1. Where the transformer spade does not provide sufficient space for cables to be connected, it may be extended with a short length of 1/4" x 4" copper bus bar, 3.86 pounds per foot, **Code M156024**. The current carrying capacity of the bus bar, when insulated with tape is as follows:
 1,200 amps for one 1/4" x 4" bus bar.
 2,200 amps for two 1/4" x 4" bus bars (one on each side of the spade).
 The spade itself has capacity sufficient for the rating of the transformer.
2. Where large size or a large number of cables are attached to secondary spade, they should be supported to prevent excessive strain on the secondary bushings.
3. Installations shown in this document **cannot** be used for aluminum cables 1,250 kcmil and larger, or copper cables 750 kcmil and larger, as the flat portion of the connector is wider than the hole spacing provided on the transformer spade.

**Connectors for Insulated Cables
Underground Distribution Systems**

**Terminal Connectors Bolted-Type
(copper cable eye bolt to flat bar for transformer spade terminals) (non-preferred)**

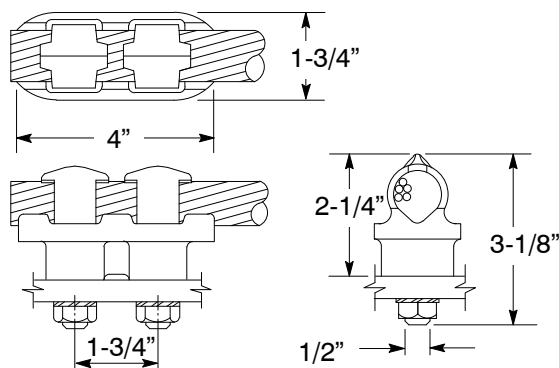

Figure 23

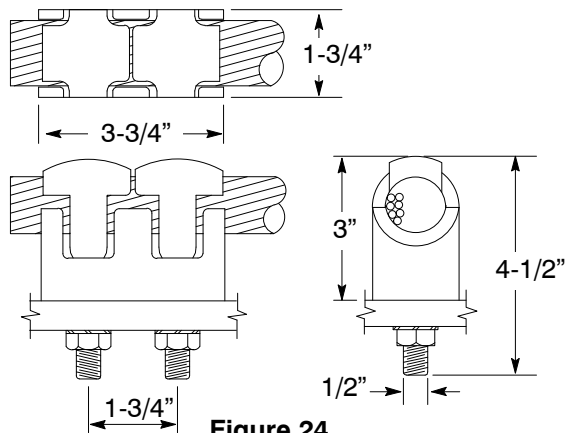

Figure 24

Table 32 Connectors (copper cable eye bolt-to-flat bar type) ¹

Use for Cable Range (AWG-kcmil)	Manufacturer and Catalog Number						Code
	Refer to	A.E. Corp. ²	Burndy	So. States	Royal	Dossert	
2/0-500	Figure 23	TLD-62	QQGF34-G6	UNNS-4656T	12222	T2L-50E	303169
600-1,100	Figure 24	TLDN-86	QQGFL44-G4	UNNS-5666T	19599	T2L-50E	303286

¹ Connectors shown in Figure 23 and Figure 24 have two cable clamping elements and require a minimum of space and taping. The recommended tightening force for the 1/2" eye bolt on these connectors is 25–40 foot-pounds.

² Formerly Anderson Brass Works.

Note

1. See Pages 24 to 29 for preferred compression connectors for this application.

Table 33 Bolts, Nuts, and Washers (Figure 23 above, Figure 28 on Page 33, Figure 36 on Page 37) ^{1, 2, 3}

Item	Description	Code
1	Screw, Cap (bolt) Everdur, Hex. Head 1/2" x 1-1/2" ^{1, 2}	193023
2	Screw, Cap (bolt) Everdur, Hex. Head 1/2" x 2" ^{1, 2}	193025
3	Screw, Cap (bolt) Everdur, Hex. Head 1/2" x 2-1/2" ^{1, 2}	193177
4	Nut, Bolt, Everdur, Hex. 1/2" ¹	195013
5	Washer, Round, Everdur, 1/2"	195252
6	Washer, Lock, Everdur, 1/2"	195193
7	Screw, Cap (bolt), Steel, CDPL, Hex. HD 1/2" x 1-1/2"	193271
8	Screw, Cap (bolt), Steel, CDPL, Hex. HD. 1/2" x 2"	193272
9	Screw, Cap (bolt), Steel, CDPL, Hex. HD. 1/2" x 2-1/2"	193273
10	Screw, Cap (bolt), Steel, CDPL, Hex. HD. 1/2" x 3"	193274
11	Nut, Bolt, Steel, CDPL, Hex. 1/2"	195449
12	Washer, Round, Steel, CDPL 1/2"	195450
13	Washer, Lock, Steel, CDPL 1/2"	195451

¹ The recommended tightening force for a 1/2" Everdur bolt is 40 foot-pounds. Normally, the use of an 8" wrench will give this range of torque.

² Everdur cap screws are low silicon bronze, Spec 651 per ASTM F468 with Class 2A threaded.

³ Use Items 1 – 6 as shown in Figure 25 on Page 32 and Figure 36 on Page 37. Use Items 7 – 13 as shown in Figure 28 on Page 33.

Connectors for Insulated Cables Underground Distribution Systems

Terminal Connectors Bolted-Type (copper cable-to-flat bar for transformer spade terminals)(non-preferred) (continued)

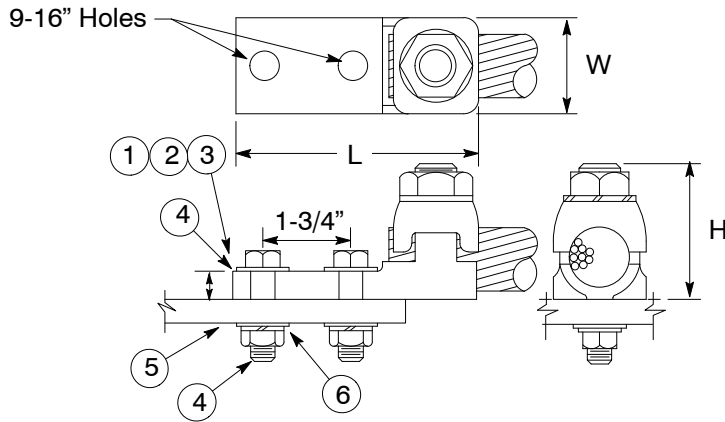

Figure 25

Table 34 Connectors – Bolted Tongue-to-Copper Cable Type ¹ (Figure 25)

Use for Cable Range (kcmil)	Manufacturer and Catalog Number			Dimensions (inches) ²				Connector Code
	Burndy	Royal	Dossert	L	W	H	T	
400-500	QA34-2N	18726	HL 50-2N	4-11/16	1-3/8	1-15/16	5/16	303188
600-800	QA40-2N	18727	HL 80-2N	4-13/16	1-5/8	2-5/16	3/8	303298
850-1,000	QA44-2N	18728	HL 100-2N	4-15/16	1-7/8	2-1/2	1/2	303189

¹ Bolt on these connectors is 40 foot-pounds of applied torque.

² Dimensions shown are for Burndy connectors; others may vary slightly.

Notes

1. Figure 26 Below shows standard transformer spade terminals per Electronic Edison Institute (EEI) Specification.

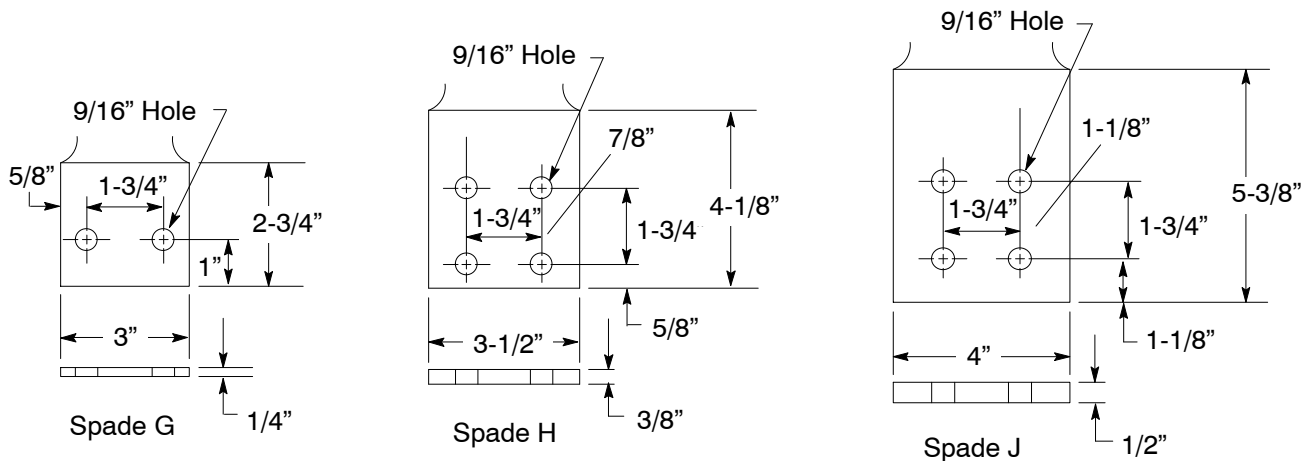

**Figure 26
Standard Transformer Spade Terminals (EEI-NEMA)**

**Connectors for Insulated Cables
Underground Distribution Systems**

**Terminal Connectors Bolted-Type
(copper cable-to-flat bar for transformer spade terminals)(non-preferred)(continued)**

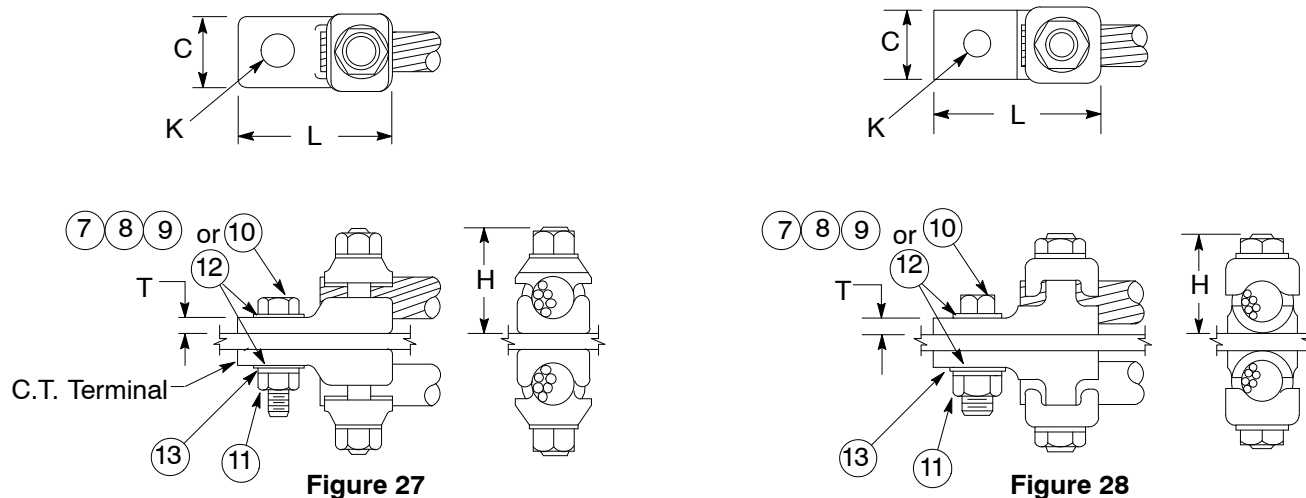

Table 35 Connectors – Copper Cable Eyebolt-to-Flat Bar Type (Figure 27 and Figure 28)

Cable Range (AWG or kcmil) Min – Max	Manufacturer and Catalog Number			Approximate Dimensions (inches) ¹				Code
	Figure 28	Figure 28	Figure 27	H	J	L	W	
	Burndy	Royal	Dossert					
2 – 350	QGFL-31B1	12208	QL35	2-3/4	1/2	1-3/4	1-7/16	303165
1/0 – 500	QGFL-34B1	12209	QL50	3-3/16	1/2	2-1/4	1-13/16	303233
750 – 1,000	QGFL-44B1	12212	QL100	3-1/2	1/2	2-1/4	2-3/16	303179

¹ The recommended tightening force for the 1/2" eye bolt on these connectors is 40 foot-pounds of applied torque.

² Dimensions shown are for Burndy connectors; others may vary slightly.

Terminal Connectors Bolted-Type (copper cable-to-flat bar for current transformer terminals only)

Table 36 Connectors – Cable-to-Flat Bar-to-Copper Cable Type (Figure 27 and Figure 28)

Cable Range (AWG or kcmil) Min – Max	Manufacturer and Catalog Number				Approximate Dimensions (inches) ¹					Code
	Figure 27	Figure 28	Figure 27	Figure 28	C	H	K (min.)	L	W	
	A.E. Corp.	Burndy	Royal	Dossert						
3/0 – 4/0	ITE024-A	QA28-B3	18723	HL 21-1-50	1	1-7/16	9/16	2-1/4	1/4	303297
250 – 350	ITE035-A	QA31-B	18724	HL 35-1	1-3/16	1-11/16	17/32	2-11/16	5/16	303182
400 – 500	ITE050-A	QA34-B	18725	HL 50-1	1-3/8	2	17/32	3-3/16	5/16	303112
600 – 800	ITE080-A	QA40-B	19600	HL 75-1	1-5/8	2-3/8	11/16	3-11/16	3/8	303122
850 – 1,000	ITE100-A	QA44-B	19601	HL 100-1	1-7/8	2-1/2	11/16	3-15/16	1/2	303121

¹ Dimensions shown are for Burndy connectors; others may vary slightly.

Notes

- Connectors shown in Table 35 on Page 33 are less costly than those shown in Table 36 and should be used when connecting one cable to bar-type primary terminal.
- Use connectors shown in Table 35 on Page 33 to connect two cables to bar-type primary terminal by placing them back-to-back as shown in Figure 27 and Figure 28.

Where severe corrosive conditions exist, use Everdur cap screws, nuts, and washers shown in Table 33 on Page 31.

Connectors for Insulated Cables Underground Distribution Systems

Tap Connectors for Cable Termination (copper or aluminum cable) Pad-Mounted Transformers

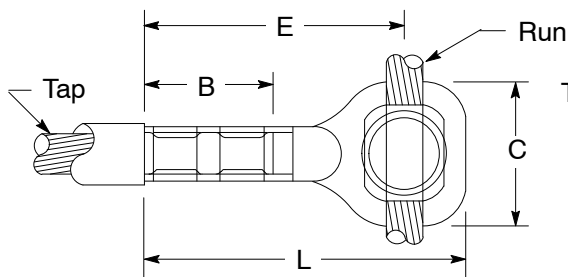

Figure 29

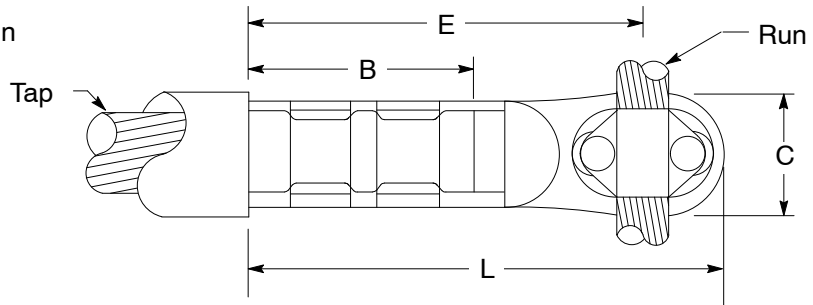

Figure 30

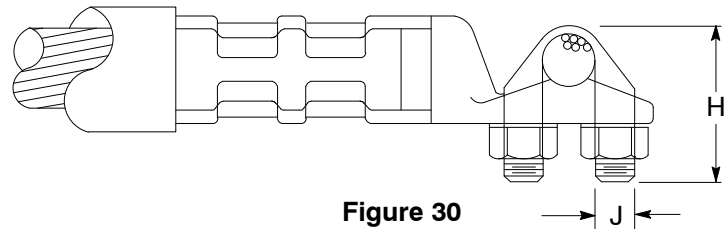
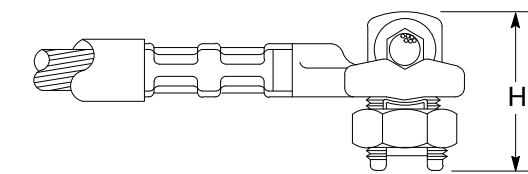

Table 37 Tap Connectors – Tee-Type (copper-to-copper, for circuits 5,000 V or lower)

Cable Size AWG or kcmil		Approved for Purchase										6-Ton Tool Dies # ¹ 12-Ton Tool Dies # 15-Ton Tool Dies #
Run	Tap	Refer to	Dimensions (inches)						Burdny Catalog Number	Dossert Catalog Number	Code	
			B	C	E	H	J	L				
6 to 2/0	2	Figure 27	1-11/32	1-5/8	2-17/32	1-13/16	-	3-7/32	VYT262CG 1	UTDK 13-6	305638	W2CRT U2CRT U2CRT ²
6 to 2/0	2/0		1-17/32	1-5/8	2-23/32	1-13/16	-	3-13/32	VYT2626G 1	UTDK 13-13	305639	W26RT U26RT U26RT ²
1/0 to 300	2	Figure 28	1-11/32	1-3/8	2-3/4	1-27/32	7/16	3-23/32	VYT302C	UTSK 30-6	305640	W2CRT U2CRT U2CRT ²
1/0 to 300	2/0		1-17/32	1-3/8	3-1/16	1-27/32	7/16	4	VYT3026	UTSK 30-13	305641	W26RT U26RT U26RT ²
1/0 to 300	250		1-21/32	1-3/8	3-1/4	1-27/32	7/16	4-7/32	VYT3029	UTSK 30-25	305642	- U29RT U29RT ²
1/0 to 300	500		2-9/32	1-3/8	3-1/16	1-27/32	7/16	5	VYT3034	UTSK 30-50	305643	- U34RT U34RT ²

¹ Within this column, the first entry corresponds to a 6-ton press tool, the second entry corresponds to a 12-ton press tool, and the third entry corresponds to a 15-ton press tool.

² A U-die adapter must be used when utilizing U-dies in a 15-Ton press.

Notes

1. If Tee Connectors, shown in Figure 29 and Figure 30 are to be attached to an aluminum overhead conductor run, use a short length of bare copper conductor between the connector and the aluminum conductor, and attach it with a fired wedge per [Document 066194](#).
2. If the desired connector size is not shown, special sizes may be acquired by ordering a connector similar to the connector shown.

**Connectors for Insulated Cables
Underground Distribution Systems**

Tap Connectors for Cable Termination (copper or aluminum cable) Pad-Mounted Transformers (continued)

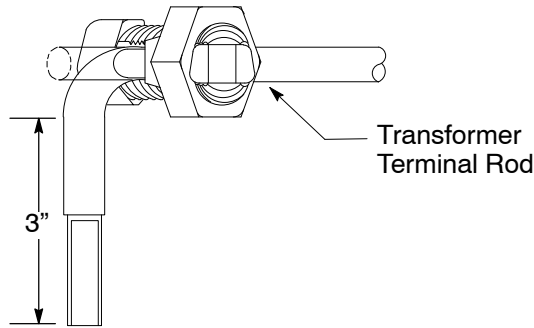

Figure 31

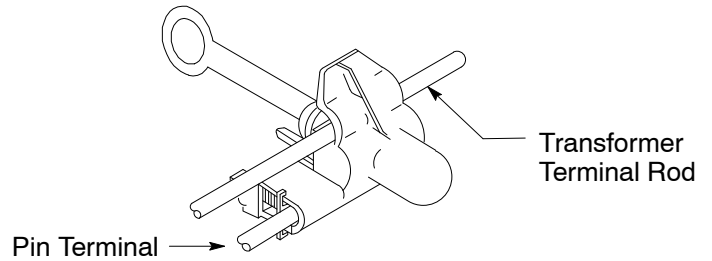

Figure 32
Blackburn Catalog Number PGH3, Code 305997
Application: Tap clamp for live-front loop-style, 3-phase pad-mounted transformer. [Document 045291](#) and [Document 057521](#) conductor range #2 AWG to 2/0.

Application

See “Low Profile” Single-Phase 6.9 and 12 kV pad-mounted transformer, [Document 042762](#).

Table 38 Tap Connectors for Cable Termination in “Low-Profile” Pad-Mounted Transformers (Figure 31)

Connector Size AWG or kcmil	Manufacturer and Catalog Number	6-Ton Tool Dies # ¹	Connector Code
	Kortick	12-Ton Tool Dies # 15-Ton Tool Dies #	
4 Cu	PMT-401	W4CRT UCRT UCRT ²	305057
2 Cu	PMT-201	W2CRT U2CRT U2CRT ²	305058
2 Al	PMTA-201	W2CART U2CART U2CART ²	305153
1/0 Al	PMTA-1001	- U25ART U25ART ²	305264

¹ Within this column, the first entry corresponds to a 6-ton press tool, the second entry corresponds to a 12-ton press tool, and the third entry corresponds to a 15-ton press tool.

² A U-die adapter must be used when utilizing u-dies in a 15-ton press.

Connectors for Insulated Cables Underground Distribution Systems

Slip-Fit Connector Installation, Aluminum or Copper Cable

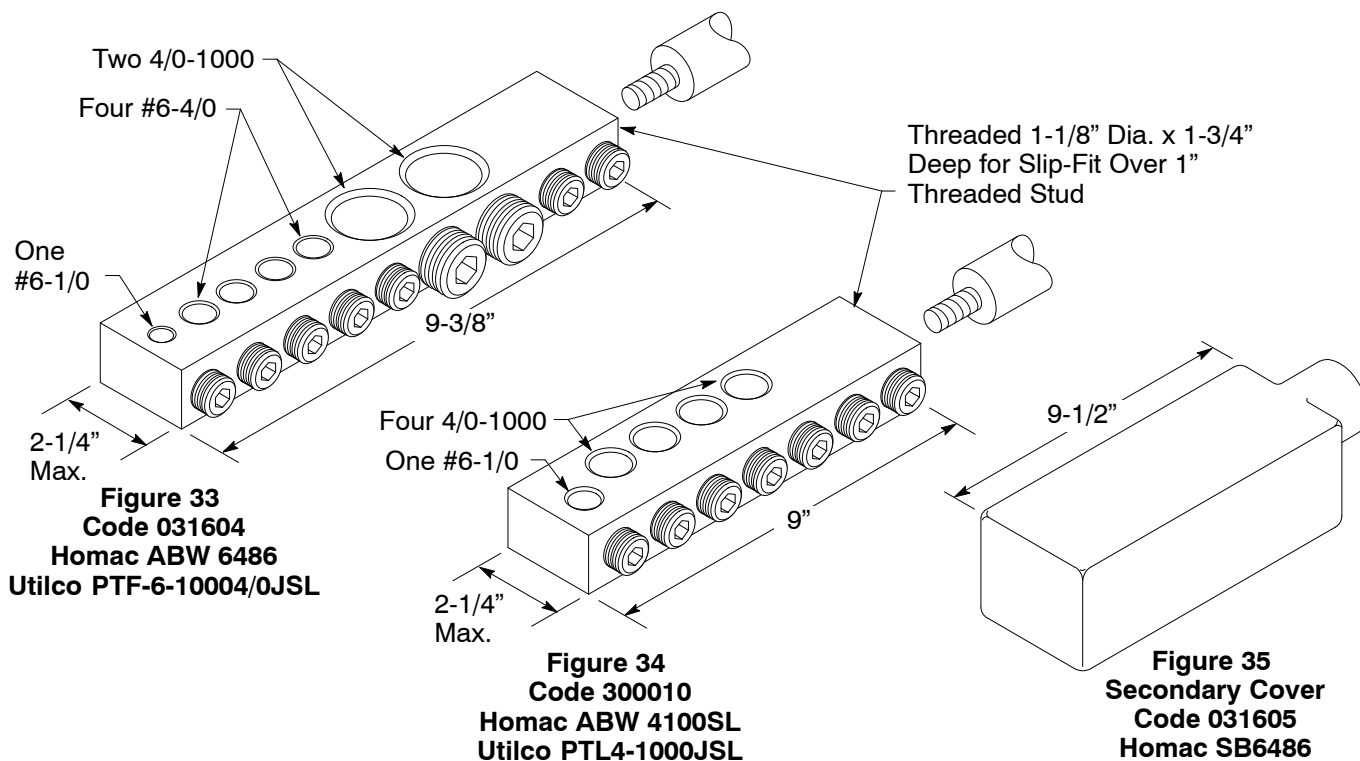

Scope

This page shows slip-fit connectors for single-phase, dead-front transformer, low voltage, secondary installations (see [Document 064308](#)).

Notes

1. All set screws to be 5/16" Allen head drive.
2. The bar is rated in excess of 1,600 amps, which exceeds the maximum allowable transformer load.
3. Connectors may be used for aluminum or copper conductors.
4. Never combine conductors in one port.
5. Connector is designed to slip onto the stud even though the terminal is threaded.
6. Secondary cover, see Figure 35, is a tool to be used when required to insulate the energized secondary slip-fit connectors.

Instructions

1. Remove any jam nuts from transformer studs.
2. Slide the connector onto the transformer stud, position the connector to allow a straight, smooth cable entry, mesh the threads together, and tighten the setscrews to lock the connector in place.
3. To prepare the cable, remove the insulation, wire brush the conductor, and apply inhibitor.
4. Insert the conductor in the port and tighten the setscrew.
5. After completing work on the secondary connectors, make sure all connections are tightened as indicated in Table 39.

Table 39 Conductor/Torque

Conductor	Torque (ft/lbs)
#6 – 350 and Transformer Stud	25
500 – 1,000	40

**Connectors for Insulated Cables
Underground Distribution Systems**

Multiple Transformer Terminal Aluminum or Copper Cable

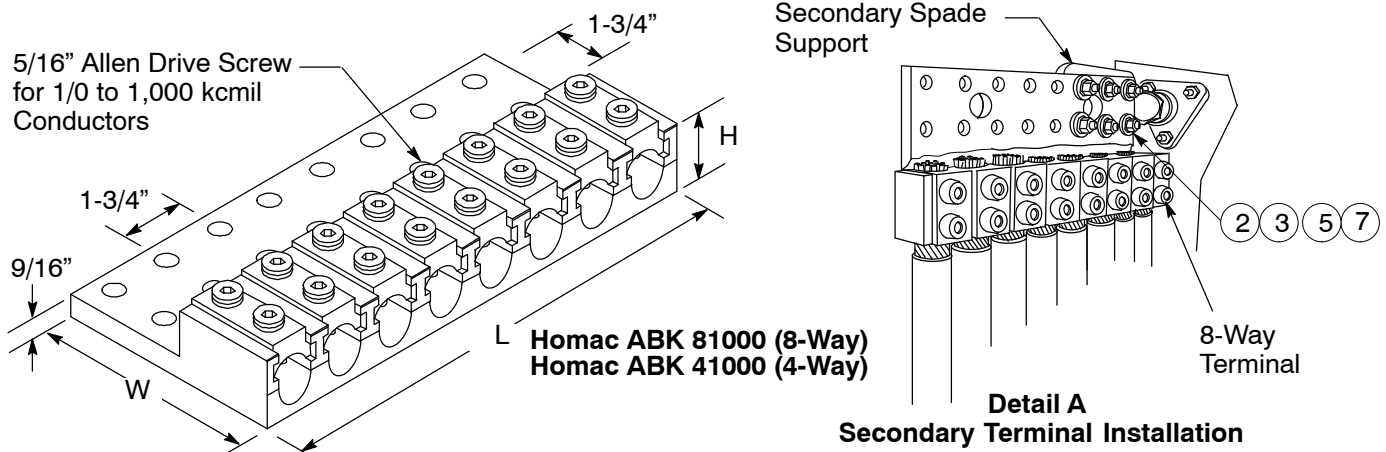

**Figure 36
8-Way Terminal Illustrated (1,000 kcmil)**

**Table 40 EZ Keeper Lay-In Terminals for Copper or Aluminum Conductors (600 V or lower)
(refer to Figure 36)**

Conductor Range	Ampacity (minimum)	Number of Conductors	Dimensions – Approximate (inches)			Mounting Hole Diameter	Code
			L	W	H		
1/0 – 1,000	3100	4	7.0	6.25	1-7/8	9/16"	301281
	5100	8	13.75	6.25			301282

Scope

These connectors are for use in connecting service cables from 1/0 to 1,000 kcmil to the spade of three-phase, pad-mounted transformers ([Document 043817](#) and [Document 045291](#)). Cable-to-flat bars are replaced in this design by set screws and a removable lay-in connection. If needed to terminate a #2 neutral onto one of these bars, it is necessary to splice a piece of 1/0 tail for insertion into the lay-in port.

Notes

1. Connectors may be used for copper or aluminum conductors.
2. Never put more than one cable in a port.
3. Install the lower (X_0 and X_2) connectors first, then the higher (X_1 and X_3). Use as many bolts as there are holes in the spade.
4. If transformer spades are not supported, install a secondary cable support kit (see [Document 045291](#)).
5. To prepare the cable, remove the insulation, wire brush the conductor, and apply inhibitor.
6. Make sure all set screws are tightened as indicated in Table 39 on Page 36. (Torque them to the specified value, wait 5 minutes, and make the final torque).
7. See Table 33 on Page 31 for bolts, nuts, and washers.

Connectors for Insulated Cables Underground Distribution Systems

Pin Terminals

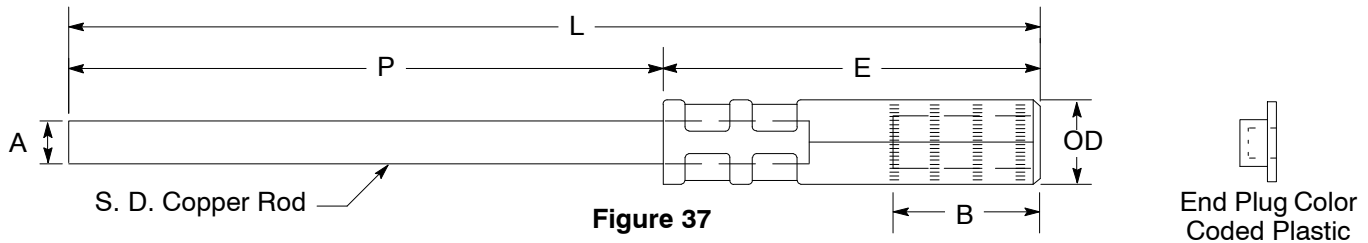

Table 41 Specifications for Aluminum Pin Terminal ¹

Copper/ Al. Cable Size	Copper Stud Equivalent	Approved for Purchase									Code	6-Ton Tool Die # ¹ 12-Ton Tool Die # 15-Ton Tool Die #
		Manufacturer and Catalog Number		Dimension (inches)								
		Homac	Brundy	A	B	OD	E Approx.	L Approx.	P			
6	8	SAPT-6-26	YE6R-40	0.250	1.75	0.65	3.25	9.25	6.00	303843	W-BG U-BG U-BG ²	
2	4	SAPT-2-26	TE2R-40	0.250	1.75	0.65	3.25	9.25	6.00	303844		
1/0	2	SAPT-1/0-26	YE25R-60	0.250	1.75	0.65	3.25	9.25	6.00	303845		
4/0	2/0	SAPT-4/0-206	YE28R-60	0.375	1.54	0.91	3.50	10.9	6.00	303846	W249 U249 U249 ²	
350	4/0	PTB-350-6	YE31AG3	0.460	2.25	1.12	4.70	10.7	6.00	303554	- U31ART U31ART ²	
500/600	500	PTM-500-346	YE34APGE	0.750	2.56	1.57	6.30	12.3	6.00	300013	- U34ART ³ U34ART ^{2,3}	
700	500	PTL-750	YE39AGB	0.750	2.56	1.60	6.30	12.3	6.00	303555	- - P39ART	
1,000	700	PTF-1000-346	YE44AG7	0.750	2.56	1.60	6.30	12.3	6.00	033757	- - P44ART	

¹ Within this column, the first entry corresponds to a 6-ton press tool, the second entry corresponds to a 12-ton press tool, and the third entry corresponds to a 15-ton press tool.

² A U-die adapter must be used when utilizing U-dies in 15-ton press tool.

³ Homac equivalent of this die is 106A.

Notes

- The material for the pin terminals is on Table 41. Copper Rod-Soft Drawn, Tinned, Aluminum Connector EC Grade, Untinned
- Connector is supplied pre-filled with inhibitor and sealed.
- Connector is supplied pre-filled with inhibitor and sealed.
- Pin terminals connected to copper secondary conductors use a copper connector. Pin terminals connected to aluminum secondary conductors use a fired wedge or h-tap.

Application

- To make straight connections of insulated aluminum secondary neutral to bare copper neutral, see Note 10 Page 8.
- To connect aluminum primary stress cone termination to terminal tap connector or cutout.
- To make watertight termination for secondary risers.

Connectors for Insulated Cables Underground Distribution Systems

Pin Terminals (continued)

Table 42 Color Coding

Color Coding Requirements for Plastic End Plugs in Pin Terminals	
Conductor Size	Plug Color
#6	Blue
#2	Red
1/0	Yellow
4/0	Pink
350	Brown
700	Purple

Table 43 Specifications and Ordering Information for Copper Pin Terminal

Cu Cable Size	Cu Stud Size	Manufacturer and Catalog Number			Dimensions (inches)						6-Ton Tool Die # ¹ 12-Ton Tool Die # 15-Ton Tool Die #	Code
		Dossert	Mac Prod Co.	Brundy	A	B	OD	E	L	P		
2	2	SDP 6-PG	CAS2-2	YE2CLH128	0.25	1.25	0.415	2.25	9.00	6.00	W2CRT U2CRT U2CRT ²	303847

¹ Within this column, the first entry corresponds to a 6-ton press tool, the second entry corresponds to a 15-ton press tool.

² A U-die must be used when utilizing u-dies 15-ton press tool.

Notes

- The material for the pin terminals on Table 43 is copper rod-soft-drawn, tinned.
- Rod may be bent for installation convenience. It is recommended that bending take place 1/2" beyond the copper sleeve.

Application

- To make straight connections of insulated aluminum secondary neutral to bare copper neutral, see Note 10 Page 8.
- To connect bare copper secondary neutral to aluminum bar connector using Thermofit boot, see [Document 036640](#).
- To make watertight termination for secondary risers.

Revision Notes

Revision 08 has the following changes:

- Updated Reference documents and also change some document links to TIL Viewer instead of D2.
- Added one row (last one listed) to Table 2 on Page 5.
- Added Table 3 and Table 4 tools and dies for compression connectors on Page 6 and Page 7 respectively.
- Revised Homac catalog part numbers for some codes in Table 5, Table 6, Table 7, Table 29 and Table 30.
- Revised Table 6 footnotes on Page 10.
- Separated codes for ground lug connectors and added requirement where (OH or UG application) to use them, P15.
- Revised Table 13 on Page 16.
- Revised Table 16, Table 17. Added new Figure 13 and 14 and revised notes on Page 18.
- Remove information about primary T connectors. These connectors are no longer used in our system.
- Revised Die number for several Copper connectors in Table 29 starting on Page 25.
- Revised concentric sizes to Table 28 on Page 24.