



Contents

INTRODUCTION TO JOB AID: OVERHEAD ASSESSMENT 5

- Overhead Job Aid Training*7
- Target Audience*7
- Before You Start*7
- DEFINITION OF MINOR WORK8
 - Examples of OH Inspection Minor Work*8
 - Requirements for Minor Work during Inspections*10
 - Requirements for Minor Work during Patrols*10
 - Minor Work Process*12
 - Recommended Work Flow Steps*13

ACCESS AND CONFIRMATIONS16

- CLIMBING SPACE19
 - Climbing Space – Obstructed*19
 - Climbing Space – Obstructed by Vegetation*21
- ADHOC INSPECTION PROCESS24

POLES/STRUCTURES25

- LEANING POLE27
 - Examples*28
- CROSS-SECTION OR HORIZONTAL CRACK31
 - Examples*32
- REDUCED CIRCUMFERENCE36
 - Examples*37
- SPLIT (VERTICAL SEPARATION)40
 - Examples*40
- OVERLOAD (BENT)46
 - Examples*47
- DECAYED / ROTTEN51
 - Examples*51
- WOODPECKER55
 - Examples*57
- SOIL EXCESSIVELY ERODED OR WASHED AWAY AT BASE OF POLE64
 - Example*64
- TRANSMISSION POLES AND DISTRIBUTION UNDERBUILD65
 - Example 1*66
 - Example 2*67
 - Example 3*69
 - Example 4*70
- SOLELY OWNED POLES WITH THIRD-PARTY UTILITY ATTACHMENTS72
- INTUMESCENT POLE COVERS72
- DISTRIBUTION TOWERS / STEEL LATTICE73
- TREE ATTACHMENTS74
 - Tree Attachments Found in the Field Procedure***75
 - Examples*78



BUDDY POLE	79
<i>Example</i>	79
EQUIPMENT	80
OIL-FILLED EQUIPMENT	80
<i>Equipment Oil: Leaking/Weeping Stain</i>	80
CORROSION	85
<i>Examples</i>	86
INTERNAL FAULT DEVICE ACTIVATED	88
<i>Example</i>	88
TRANSFORMER – PARALLEL	89
<i>Examples</i>	89
TRANSFORMER BUSHINGS.....	90
<i>Examples</i>	90
SMARTMETER / SCADA EQUIPMENT / OTHER EQUIPMENT ON POLES	91
<i>Broken/Damaged SmartMeter Relay/Access Point/Data Collector Unit or SCADA Equipment</i>	91
SWITCH HANDLE/CONTROL BOX IS NOT LOCKED.....	93
SURGE “LIGHTNING” ARRESTORS	93
<i>Broken or Flashed</i>	93
LOOSE HARDWARE	95
CONDUCTOR.....	96
BARE PRIMARY & SECONDARY CONDUCTOR.....	96
<i>Part 1</i>	96
VIBRATION DAMPER	98
WEDGE CONNECTORS.....	115
<i>Part 2</i>	120
SERVICE CONDUCTOR	145
<i>Category 1 – Exposed hot leg on the service</i>	145
<i>Category 2 – Broken Service Bob</i>	155
<i>Category 3 – Conductor Clearance</i>	157
CLEARANCE EVALUATION JOB AID	158
COVERED CONDUCTOR.....	176
<i>Category 1 – Exposed energized portions on covered conductor</i>	176
CROSSARM / INSULATORS / CUTOUTS	181
FRAMING.....	181
1. <i>Crossarm Broken/Deteriorated</i>	181
2. <i>Bonding Exists and Needs to be Repaired</i>	187
3. <i>Underarm Bus Not Securely Attached</i>	189
INSULATORS.....	192
1. <i>Damaged Insulators</i>	192
2. <i>Squatters – Primary or Secondary</i>	196
3. <i>Flying Bells</i>	198
4. <i>Cotter Key</i>	198
CUTOUTS / FUSES / SWITCHES.....	201
1. <i>Damaged Arcing Horns</i>	201
2. <i>Cutouts</i>	201



3. Fuses203
Liquid Filled Fuses203

CALIFORNIA POWER LINE FIRE PREVENTION FIELD GUIDE207
 CALIFORNIA POWER LINE FIRE PREVENTION FIELD GUIDE207

MISCELLANEOUS OTHER COMPELLING ABNORMAL CONDITIONS207

GUYS / ANCHORS.....207
Down Guy Preform Buried207
Visible Portion of Anchor Rod has Significant Corrosion212
Guy Broken / Slack / Corroded213
Guy Clearance Issue215
Down Guy Grounded above Guy Insulator (vegetation or other)221
Down Guy Marker Missing/Damaged224

GROUNDS / GROUND MOLDING228
Exposed Ground Below 8'228
Exposed Ground above 8' to the Communication Level.....232
Ground Molding Unsecured/Loose234
Exposed Ground Rod.....236
Broken Grounds237

MARKINGS.....240
High Voltage Sign Not Installed as Required.....240
Operating Number Incorrect / Illegible / Missing244
Damaged or Missing Visibility Strips on Poles / Guy Markers247

STREETLIGHTS.....253
Broken or Damaged Streetlight Pole.....253
Day Burner255
Missing Streetlight Head.....255

WILDLIFE PROTECTION256
Existing Migratory Bird Protection Damaged256
Exiting Wildlife Protection Damaged258
Bird protection.....258

RISER MOLDING.....259
Broken/Missing Riser Ground259
U-Shape Riser Molding Broken/Damaged or Unsecured259

POLE STEPS261

DECLARATION ITEMS261

TREES261
Trees within 4 Feet of a Primary Line261
Trees Causing Strain or Abrasion to a Secondary Conductor or Service.....265
Trees Overgrown, NOT Causing Strain or Abrasion to a Secondary Conductor or Service269

IDLE FACILITIES271
Identifying and Documenting Idle Facilities.....271
Energized Electric Line Facility No Longer Used to Serve Customer Load275
De-Energized Electric Line Facility Already Identified on a Pending EC Notification but Not Mapped276
Idle Hardware276
Abandoned Pole Butt276



Job Aid: Overhead Assessment

TD-2305M-JA02

Publication: Jan 4, 2024, Effective: Feb. 1, 2024

Rev: 12

3 RD PARTY NOTIFICATION.....	279
<i>Utility – Cable, Phone, and other Electric Utility Partners.....</i>	279
<i>Antennas - Third Party Communication.....</i>	283
<i>Non - Utility.....</i>	284
FDA - DISTRIBUTION OH FACILITY DAMAGE ACTION TABLE	287
TABLE 1	287



Introduction to Job Aid: Overhead Assessment

This job aid is designed to assist Electric Distribution Compliance Inspectors, PG&E Employees, and Contractors in assessing and prioritizing compelling **abnormal conditions** on overhead facilities, including but not limited to GO 165 Inspections. Compelling Abnormal Condition is defined as any electric distribution pole, equipment, component, conductors, vegetation, or third-party condition that causes a safety or fire ignition risk that, in the judgment of the field employee, may adversely impact public safety and/or service reliability.

The field employee’s primary responsibility when inspecting an overhead electric facility is to **examine and record any compelling abnormal conditions** and per GO95 Rule 18 level 3 conditions that can be completed as opportunity work. This job aid provides guidance on issues that field employees may encounter most frequently in the field but is not intended to be an all-inclusive listing of all abnormal conditions or corrective actions.

During any inspection or field assessment, the field employee may change the priority of any EC Tag based on the field conditions.

Proposed PG&E Prioritization				
	PG&E Priority	Tier 3	Tier 2/HFRA	Non-HFTD
Level 1: immediate risk of high potential impact to safety and reliability	A	Within 24 hours	Within 24 hours	Within 24 hours
Level 2: at least moderate potential impact	X	Up to 5 days	Up to 5 days	Up to 5 days
	B	Up to 6 months	Up to 6 months	Up to 6 months
	E	Up to 6 months	Up to 12 months	Up to 36 months
Level 3: low potential impact	F	60 months	60 months	60 months

Field personnel will continue to have the ability to set deadlines shorter than the default deadlines for B and E tags based on specific location / consequence potential.



Job Aid: Overhead Assessment

TD-2305M-JA02

Publication: Jan 4, 2024, Effective: Feb. 1, 2024

Rev: 12

The statement “Minor Work” referenced in this document is specific to compliance inspectors.

When in the field, if a compliance inspector completes minor work, the work must be completed to current construction standards, with the exception of make-safe situations.

The FDA (Facility Type / Damage / Action) located in [Table 1](#) at the bottom of this document provides general guidance on EC tag notification for the specific scenario.

Overhead Job Aid Training



- Refresher Training
 - TECH-0020
- The Annual Refresher Training program is designed for PG&E’s Compliance Inspectors who conducted detailed inspections in the previous year. Content includes explanations of changes to the annual inspection program, mobile applications, and the checklist. A review of this Job Aid is included in this course.
-
- New Inspector Training
 - ELEC-1000
- The New Inspector Training program is a 3-day training program designed for new Compliance Inspectors and Canus contractors who may be assigned Electric Distribution GO165 Overhead/Underground inspection and patrol work. A review of this Job Aid is included in this course.
-
- New Contractor Training
 - ELEC-0340, 0341, 0342
- The New Contractor Training program is a 3-day training program, followed by an assessment day plus a 2 day in-the-field-training. It is designed for new contractors who will be assigned Electric Distribution GO165 Overhead inspection work. A review of this Job Aid is included in this course.

Target Audience

- Qualified Electrical Workers (QEW)

Before You Start

- Follow all applicable safety rules, procedures, and protocols.
- Wear appropriate personal protective equipment (PPE) for specific tasks and work area.

Uniform Symbols for Job Aid	
Symbol	Definition
	Ground
	Aerial+

Definition of Minor Work

Minor Work is maintenance work and/or repair activities that can be accomplished safely and efficiently at the site of the electric distribution facility by the Inspector.

Minor Work is recorded using your approved electronic device.

Within the mix of supporting PG&E's OH and UG Electric Distribution system, Minor Work is a highly effective process that immediately improves reliability, operational safety, and public safety. It is also the most cost-effective preventive maintenance model used by M&C.

Examples of OH Inspection Minor Work

Examples of OH Minor Work are grouped **below 8 feet** for Inspectors who do not have bucket trucks and **above 8 feet** for those who do have bucket trucks.

- **Below 8 feet**
 - (1) Anchor - Adjust/Repair
 - (2) Ground - Repair/Replace
 - (3) Guy - Adjust/Repair/Trim
 - (4) Marking - Install/Replace
 - (5) Molding - Install/Repair/Replace
 - (6) Pole Step - Install/Remove
 - (7) Tree – Trim
 - (8) Unauthorized Attachments – Remove

- **Above 8 feet**
 - (1) Conductor - Adjust/Repair/Replace
 - (2) Connector – Replace
 - (3) Crossarm – Repair
 - (4) Ground - Repair/Replace
 - (5) Guy - Adjust/Repair/Replace





Job Aid: Overhead Assessment

TD-2305M-JA02

Publication: Jan 4, 2024, Effective: Feb. 1, 2024

Rev: 12

- (6) Guy - Install/Trim Veg.
- (7) Hardware - Repair/Replace
- (8) High Sign - Install
- (9) Marking - Install/Replace
- (10) Molding -Install/Repair/Replace
- (11) Pole – Repair
- (12) Streetlight - Install/Repair/Replace
- (13) Tie Wire - Replace
- (14) Tree – Trim
- (15) Unauthorized Attachment – Remove



Requirements for Minor Work during Inspections

The Compliance Inspector performs Minor Work during Inspections when the following conditions **are met**:

- It is **safe** to do so.
- You have appropriate tools.
- The facility has no Pending EC Notification, or you **can** complete all FDAs as minor work.

There are three (3) scenarios when clearing excessive vegetation as Minor Work is **not appropriate**.

Scenario: OH Inspection

IF there is **too much** vegetation to be cleared safely,

THEN Use an EC Form to identify that you cannot complete the OH Inspection until the vegetation is removed. In this case you would use these FDAs:

- FDA 1: Tree/Vine, Clearance, Remove
- FDA 2: OH Facility, Limited Access, Inspect
- Priority 'B'
- Recommended Due Date 0-3 month, **not to exceed the CPUC Due Date** for the Map

Requirements for Minor Work during Patrols

Generally, Minor Work is **not** performed during a patrol.

The Compliance Inspector performs Minor Work during Patrols when the following conditions **are** met:

1. It is **safe** to do so.
2. You have appropriate tools.
3. There **is** a safety hazard.

During Patrols, there are only two (2) scenarios when Minor Work should be performed by the Compliance Inspector.



Scenario 1: Safety Hazard / Pending EC Notification

IF a Pending EC Notification FDA is a safety hazard

THEN Use the Pending EC Notification shop paper to record the minor work completed by you.

(a) Check the boxes titled 'Completed'

(b) Date and sign the Pending EC Notification

Scenario 2: Safety Hazard / Able to make safe.

IF a safety hazard can be fixed with Minor Work,

THEN Use the OH/UG Minor Work Form to record the minor work.



Minor Work Process

1. Preparing For Daily Work

- Make sure you have safety equipment, tools, and materials so you can perform **Minor Work** while performing inspections.

2. During an Inspection

- After you have determined that Minor Work can be done **safely**, complete all Minor Work repairs for the facility.

- For each facility, you may perform Minor Work

Note: Be sure to confirm with your PS&R office to confirm how many hours you are authorized to perform Minor Work.

4. After an Inspection

- Use your Timecard to record the time worked on this map.



Recommended Work Flow Steps

1. While working your map, do so in accordance with safety practices
2. Inspect the facility
3. Determine if Minor Work is appropriate
4. Observations may include one of these **six (6) scenarios**:

Scenario 1: Minor Work Not Required IF there are **no compelling abnormal conditions** or regulatory conditions,

- THEN** (1) Complete in Inspection App
(2) Move to next facility

Scenario 2: Minor Work Required / No Pending EC Notification

IF you **can resolve all compelling abnormal conditions** and/or regulatory conditions

- THEN** (1) Perform Minor Work
(2) Use the appropriate Minor Work Form to record your work
(3) Complete in Inspection App
(4) Move to next facility



Scenario 3: Complete Pending EC Notification

IF you **can resolve all compelling abnormal conditions** and/or regulatory conditions by completing all FDAs on a Pending EC Notification as Minor Work

- THEN**
- (1) Perform maintenance repairs as Minor Work
 - (2) Complete FDAs on Pending EC Notification
 - (3) Complete in Inspection App
 - (4) Move to next facility

Scenario 4: Update Pending EC Notification

IF there are new Minor Work activities identified by you, but they are **not** listed on the Pending EC Notification

- THEN**
- (1) **Do not** perform any Minor Work
 - (2) Add new FDAs to the Pending EC Notification
 - (3) Complete in Inspection App
 - (4) Move to next facility

Note 1: If the minor work is an immediate safety hazard, then perform the repair to make safe (for example, exposed ground in the first 8 feet with access to the public).

If the FDA you repaired is on the Pending EC, then complete the FDA on the EC and write “**Minor Work completed to make safe**” in the comment section.

Note 2: The crew, responding to the EC Notification, will perform the Minor Work. In this case, an FDA for the Minor Work is included in the Pending EC Notification.



Scenario 5: Write New EC Form

IF Minor Work **cannot resolve all** abnormal conditions and/or regulatory conditions that require an EC Notification

THEN (1) **Do not** perform any Minor Work

- (2) Use the EC Notification to document conditions
- (3) Complete in Inspection App
- (4) Move to next facility

Note 1: If the minor work is an immediate safety hazard, then perform the repair to make safe (for example, exposed ground in the first 8 feet with access to the public). Use the appropriate Minor Work Form to document the make safe repair work.

Note 2: The crew, responding to the EC Notification, will perform the Minor Work. In this case, an FDA for the Minor Work is included in the EC Form.

Scenario 6: New EC Work Form for Capital Minor Work

IF you completed Capital Minor Work (OH Full-Service Replacement)

THEN (1) Indicate the Location on your map.

- (2) Use the EC Notification to document conditions and complete the EC Notification
- (3) Complete in Inspection App
- (4) Move to next facility



Access and Confirmations

This section outlines the requirements for an inspection to occur on a pole. If any of the following are not possible, please answer the question “Were you able to complete an Inspection” “NO” and follow prompts in App to record the reason.

Determine if structure and associated conductor is accessible.

OH Inspections: Inspection Requirements

- You must be at the structure, achieve a 360-degree view of the entire structure from bottom to the top.
- You are required to view all conductor(s) to mid-span or to the weather-head or to the termination point –
- If you are unable to perform the two tasks above, you will be required to create a CGI notification in the Inspect App

Determine if the structure is an inspectable or not inspectable structure type.

1. Inspectable Structures: (Answer Yes to were you able to complete an inspection)
 - a. Distribution Pole/Tower: Includes Push Pole (Non-Haloed Push Poles perform Ad-Hoc process)
 - b. Transmission Pole with Distribution Underbuilds (Steel or Wood)
 - c. Idle Pole
 - d. Streetlight on Distribution Pole
 - e. Tree-Connect

Note: 2 Photos of ENTIRE structure are required for each of the above types (including trees and transmission underbuilds). It is acceptable to not be able to see the entire structure top to bottom in the photos as long as inspector is able to inspect the structure top to bottom.

Likewise, when taking photos of top third/ Middle Third/ and Bottom Third. Consider the thirds of the ENTIRE structure as well (including top of transmission pole or tree)

2. Not inspectable (Follow Asset Discrepancy Steps)
 - a. Structure does not exist in the field.
 - b. Structure is in the field; Structure is Customer-Owned. It is inspected by the Customer.
 - c. Structure is in the field; Pole is a streetlight-only pole. It is inspected by another program.
 - d. Structure is in the field; Pole is a Communication-only pole. It is inspected by another program.
 - e. Structure is in the field; Pole is a Transmission-only pole. It is inspected by another program.

A detailed inspection includes the following:

- Perform field inspection



- Assess field conditions
- Identify and record compelling abnormal conditions, regulatory conditions, and third-party caused infractions that negatively impact safety or reliability.
- Take photos of field conditions and PG&E assets
- Complete and document your inspection results, observations, findings, & photos
- Validate Pending EC Notifications when required

Note: A structure is accessible as long as inspector is able to get a visual 360 of the structure and full view of its conductors midspan in all direction and connection to the termination. It is understandable that photos of the structure and conductors may include vegetation obstructing the view of part of the pole or conductor; this is not a CGI.



Job Aid: Overhead Assessment

TD-2305M-JA02

Publication: Jan 4, 2024, Effective: Feb. 1, 2024

Rev: 12





Climbing Space

Climbing Space – Obstructed

General Guidance: Evaluate pole to determine whether there is an obstruction caused by PG&E facilities or by third party facilities that is causing a compelling safety issue – based on the location of the pole and exposure to the worker - that needs to be addressed in 5 years.

Example: Equipment pole that cannot be accessed in a bucket truck.

Example: Pole in rear easement with secondary or service connection failures.

Example: where the climbing space **is not** a compelling condition: Equipment pole that is accessible 100% of the time in a bucket.

For PG&E obstructions: Create an EC notification.

For third party obstructions: Create a third-party notification if they pose a significant safety hazard.

If a third-party obstruction is causing an emergency safety or reliability issue, contact your supervisor for instructions.

Minor Work: No



EC Notification: Yes, if not able to perform minor work



Third Party Notification: Yes, if obstructed by third party

Select the Priority and Due Date based upon compelling abnormal condition that may adversely impact public safety and/or service reliability.

Related Documents: [066210](#)

Examples

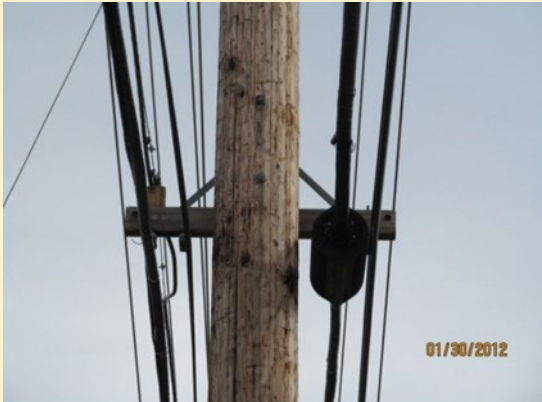
COMMUNICATION IN CLIMBING SPACE	
	<p>At this Location:</p> <p>Obstructed climbing space, access via bucket truck from street below. Also, look for clearance issues between communications facilities and the PG&E down guys.</p> <p>   </p>
	Perform Minor Work: No
	Write 3rd Party Notification: No
	Write EC Notification: No

CLIMBING SPACE OBSTRUCTED	
	<p>At this Location:</p> <p>Climbing space obstruction by communication facilities on pole with equipment. Communication messengers are too close. No bucket truck access.</p> <p>   </p>
	Perform Minor Work: No
	Write 3rd Party Notification: Yes
	Write EC Notification: No



Climbing Space – Obstructed by Vegetation

General Guidance: For incidental vegetation in climbing space that can be moved when climbing, or quickly cleared prior to climbing, no action is required.

For major vegetation that cannot be quickly cleared or moved prior to climbing, evaluate the pole:

- Is there supply equipment on the pole that may need to be operated during emergency conditions?
- Should the obstruction be cleared for any other safety or reliability reason?

If the answer is yes to any of these questions, the inspector will need to create an EC Notification to clear vegetation unless it can be addressed as minor work.

Minor Work: Yes





EC Notification: Yes, if not able to perform minor work

Select the Priority and Due Date based upon compelling abnormal condition that may adversely impact public safety and/or service reliability.

Related Documents: [066210](#)

Examples

OBSTRUCTED CLIMBING SPACE	CLIMBING SPACE OBSTRUCTED
	
<p>At this Location: Obstructed climbing space. Inspector cannot see enough of the pole to complete Inspection (heavy vegetation, cannot see through). No equipment on pole. The only reason to address is to complete the inspection.</p> <div data-bbox="204 1108 339 1173"> </div>	<p>At this Location: Climbing space obstruction, able to perform inspection, no equipment on pole (able to see guys, able to see up the pole under tree)</p> <div data-bbox="764 1035 899 1100"> </div>
<p>Perform Minor Work: No</p>	<p>Perform Minor Work: No</p>
<p>Write 3rd Party Notification: No, only need clearing to perform inspection</p>	<p>Write 3rd Party Notification: No</p>
<p>Write EC Notification: Yes</p> <p>FDA = OH Facility / Limited Access/Obstruct / Inspect (Primary)</p> <p>FDA= OH Facility / Limited Access/Obstruct / Remove</p> <p>Priority = B tag, 0-3 months depending upon exposure; must complete before CPUC due date for map</p>	<p>Write EC Notification: No</p>

POLE WITH VEGETATION	IVY COVERED POLE
	
<p>At this Location: 360° pole inspection not possible</p> 	<p>At this Location: 360° pole inspection not possible</p> 
<p>Perform Minor Work: No</p>	<p>Perform Minor Work: No</p>
<p>Write 3rd Party Notification: No</p>	<p>Write 3rd Party Notification: No</p>
<p>Write EC Notification: Yes</p> <p>FDA = OH Facility / Limited Access/Obstruct / Inspect (Primary)</p> <p>FDA= OH Facility / Limited Access/Obstruct / Remove</p> <p>Priority = B Tag, depending upon exposure; must complete before CPUC due date for map</p>	<p>Write EC Notification: Yes</p> <p>FDA = OH Facility / Limited Access/Obstruct / Inspect (Primary)</p> <p>FDA= OH Facility / Limited Access/Obstruct / Remove</p> <p>Priority = B Tag, depending upon exposure; must complete before CPUC due date for map</p>



Adhoc Inspection Process

General Guidance: The Adhoc Inspection Process can be used for any unmapped distribution structure i.e., a structure without an SAP number.

Warning: Once Adhoc inspection process is submitted, there is **NOT** a process to cancel if a mistake is made. The cancellation must be done manually by a distribution asset strategist by emailing DistributionAssetStrategist@pge.com.

In the Inspect App:

Come across a Distribution Structure / Tree Connect that is unmapped within the map and have already started the work order:

1. Investigate to ensure that the structure is not located somewhere else on the map.
 - a) If mapped but in the wrong location:
 - Perform the inspection on the map structure and create a map change to move the structure to the correct location.
 - b) If confirmed unmapped
 - On map screen long touch screen at the exact location that the structure exists to drop a pin.
 - Actions Button
 - Start Adhoc Inspections Button
 - Complete "Add-Pole" Map correction form.
 - Complete Inspection Form

Note: Customer owned pole should only be selected when the pole being inspected is customer owned with PG&E equipment.



Poles/Structures

General Guidance: Is the pole damaged, broken, rotten, cracked outside what would be considered normal, leaning beyond 10%, or needing to be identified for any other reason? If yes, create EC notification.

Observations in the field may include the following situations:

- Leaning Pole
- Reduced Circumference
- Split (Vertical Separation)
- Overload (Bent)
- Decayed / Rotten
- Woodpecker
- Cross-section or Horizontal Crack
- Soil Excessively Eroded or Washed Away at Base of Pole
- Transmission Poles with Distribution Underbuild
- Solely Owned Poles with Third-Party Utility Attachments
- Intumescent Pole Covers

The following guidance is to ensure adherence to G.O. 95 Rule 44.3 and 47.3:

Pole Damage– At any attachment level on the pole, evaluate the below conditions to determine if the criteria are met for an EC tag:

- Multiple vertical cracks in the same proximity to each other
- Pole twist causing spiral cracks.
- Checks causing an un-natural taper to the exterior diameter of the pole (checks being forced opened).
- Hardware sinking into the pole, e.g., not naturally sitting on the outside of the pole.
- Multiple issues existing on a single structure, e.g., Pole degradation, insect/woodpecker damage, and/or any other abnormal compelling conditions.

X Tag - Details on these conditions are described in tables and flowcharts below

1. Bent or overloaded horizontal break condition. Refer to flow chart in Overload (Bent) section.
2. Loss of circumference >30%
3. Pole is leaning >20%
4. Vertical Cracks, splits, or damage that are impacting the structural integrity on any attachment points where hardware has moved from its original installation location and no split bolt in proximity.



E Tag

Consider a higher priority depending on condition of the pole and exposure.

- Horizontal Break in the grain or cuts that meet criteria. See flow chart below.
- Vertical Cracks, splits, or damage at any attachment points impacting structural integrity that are loose (compelling abnormal condition), regardless of the existence of a split bolt.
- Substantial deterioration or damage present inside the vertical cracks or splits.
- Vertical cracks that split the pole in half and you can see through.

Related Documents: [TD-2305M](#) EDPM Pole Inspection, [TD-2325S](#), [066209](#), [G.O. 95 Rule 44.3 and 47.3](#).

Definitions:

1. **Buckling** at the ground line or an unusual angle with respect to the ground may indicate that the pole has rotted or is broken.
2. **Cracks** -
 - a. **Horizontal cracks (Breaks)** perpendicular to the grain of the wood may weaken the pole.
 - b. **Vertical cracks**, although not normally considered to be a sign of a defective pole, can pose a hazard to the climber, and the employee should keep his or her gaffs away from them while climbing.
3. **Checks (Vertical)** are a natural separation of the wood normally occurring across or through the rings and usually as a result of seasoning. Surface seasoning checks have a negligible effect on all strength properties.
4. **Splits (Vertical)** are a separation of the wood through the piece to the opposite surface or to an adjoining surface due to the tearing apart of the wood cells.
5. **Holes**. Hollow spots and woodpecker holes can reduce the strength of a wood pole.
6. **Shell rot and decay**. Some poles have a strong outside shell and a center more susceptible to internal decay or 'heart rot', Others have a strong center and tend to decay externally, called 'shell rot.'
7. **Knots**. One large knot or several smaller ones at the same height on the pole may be evidence of a weak point on the pole.
8. **Depth of setting**. Evidence of the existence of a former ground line substantially above the existing ground level may be an indication that the pole is no longer buried to a sufficient depth.
9. **Burn marks**. Burning from transformer failures or conductor faults could damage the pole so that it cannot withstand changes in mechanical stress

Leaning Pole

General Guidance: Consider the following when evaluating a leaning pole:

- Lean vs Bend: Lean is a foundational issue where the structure is straight and not bent. Bend is where the structure has a curve.
- Is the leaning pole causing excessive conductor sag or reduced clearance issues that could result in contact, fire risk, or public safety?
- Does the lean appear as if it will become worse or affect safety (considering environmental and configuration factors -soil, wind, pole attachments, equipment, guying)?



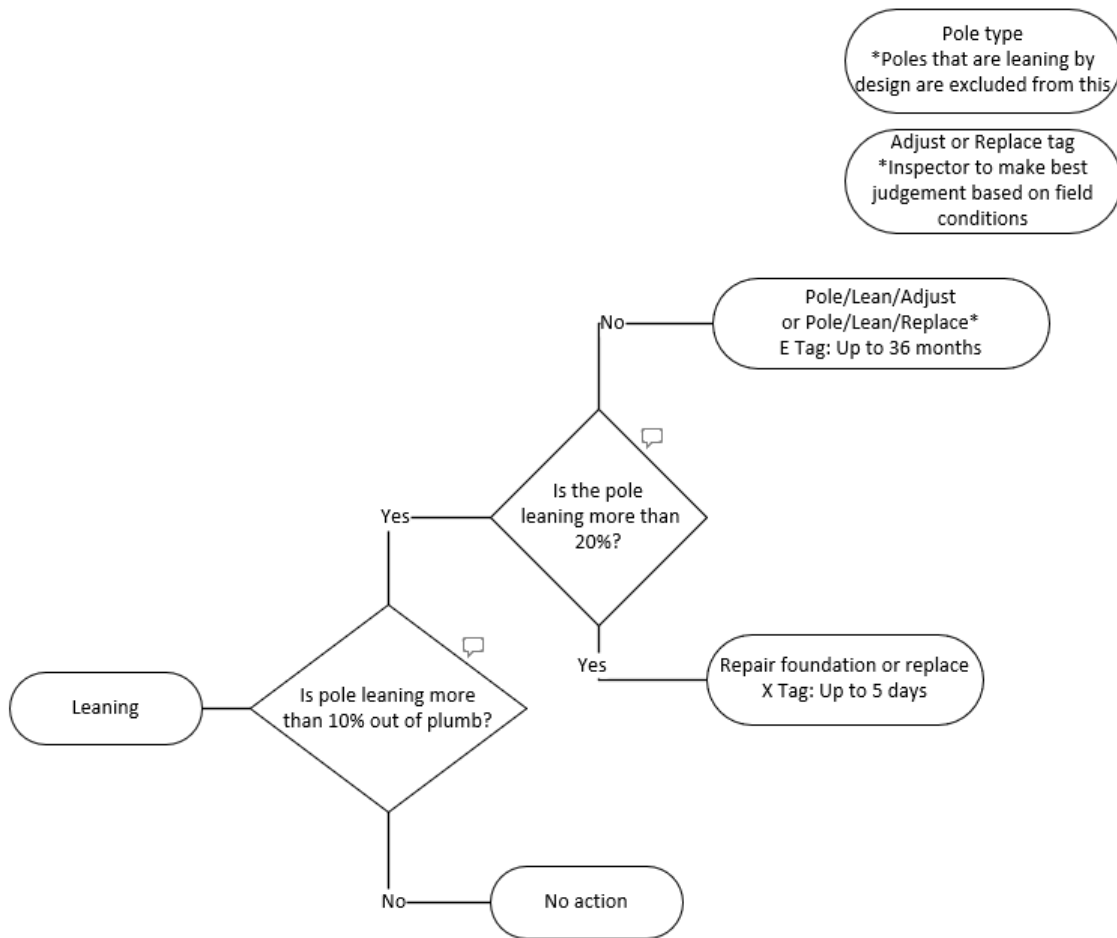

Note: If the Inspector suspects that a third-party attachment is causing the pole to lean, consider writing a Third-Party Utility notification in addition to an EC Notification.

Select the Priority and Due Date based on flow chart and field conditions.





Related Documents: [023058](#), [TD-2014S](#) – Third Party Damage, [030109](#) – Mud Sill





Examples

LEANING POLE	LEANING SLACK SPAN
	
<p>At this Location: Leaning pole greater than 10% out of plumb. No equipment, in rural area.</p> 	<p>At this Location: Leaning towards a tree more than 10% and less than 20% out of plumb. Inspector pulled plug and confirmed pole is solid below ground.</p> 
<p>Perform Minor Work: No</p>	<p>Perform Minor Work: No</p>
<p>Write 3rd Party Notification: No</p>	<p>Write 3rd Party Notification: No</p>
<p>Write EC Notification: Yes FDA= Pole / Leaning / Adjust</p>	<p>Write EC Notification: Yes FDA= Pole / Leaning / Replace</p>
<p>Priority= Minimum E Tag, depending on exposure</p>	<p>Priority= Minimum E Tag, depending on exposure</p>



STUBBED POLE LEANING TOWARDS SCHOOL	POLE BENDING 3 POT TRANSFORMER IN BUCK POSITION
	
<p>At this Location: Stubbed pole leaning more than 10% and less than 20% towards school, supported by down guy. Pole Bands are loose due to additional deterioration of the pole.</p> 	<p>At this Location Pole is leaning less than 10% out of plumb, bending in direction of offset equipment. Go to overload (bent) flow chart.</p> 
<p>Perform Minor Work: No</p>	
<p>Write 3rd Party Notification: No</p>	
<p>Write EC Notification: Yes FDA= Pole / Lean / Replace Priority= Minimum E Tag, consider shorter duration due to exposure</p>	



POLE LEANING NEAR RAILROAD TRACKS	
	<p>At this Location: Severe lean greater than 20% with low conductor over railroad.</p> <p>   </p>
	<p>Perform Minor Work: No</p>
	<p>Write 3rd Party Notification: No</p>
	<p>Write EC Notification: Yes FDA= Pole / Lean / Replace</p> <p>Priority= A Tag, follow the emergency process</p>

Cross-section or Horizontal Crack

General Guidance: Slice is a reduction in cross sectional area. It could be horizontal and can include mechanical damage, horizontal cracks, or cuts into pole. Circumferential damage to only 1 side of the pole. If the damage is large enough in relation to the size of the pole, write EC tag for Pole / Broken / Damage / Replace.

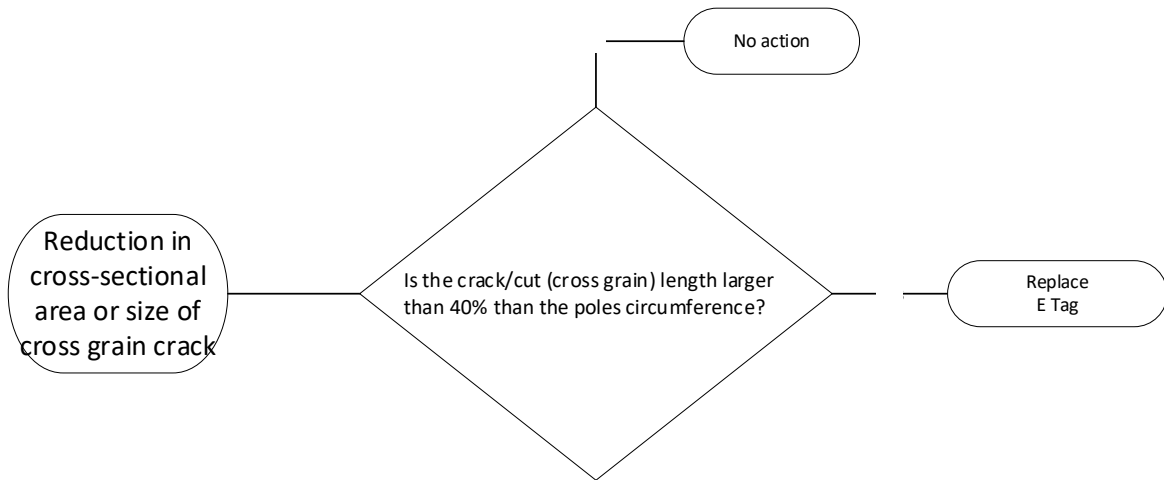

This is event driving (1 time) No mechanism to make it bigger

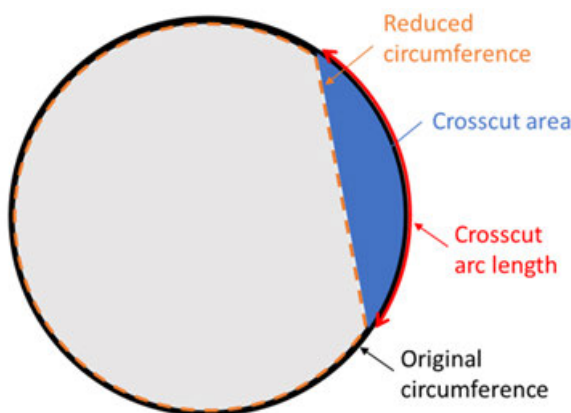









Figure 1: Schematics of a Pole Cross Section



Figure 2: Definition of Crosscut Arc Length

Examples

BROKEN POLE	
	<p>At this Location: Broken pole, not supported.</p> <div style="display: flex; gap: 5px;">   </div>
	<p>Perform Minor Work: No</p>
	<p>Write 3rd Party Notification: No</p>
	<p>Write EC Notification: Yes FDA= Pole / Broken / Damaged / Replace</p>
	<p>Priority= A Tag, Follow the Emergency Procedure Note: Flow chart doesn't lead us here, but inspector should use knowledge as a lineman to identify</p>

CUT INTO POLE	
	
<p>At this Location: Vandalized pole. Chain saw cut into lower portion of pole. Arc length 20 inches (>40% circumference)</p>	
<p>   </p>	
<p>Perform Minor Work: No</p>	
<p>Write 3rd Party Notification: No</p>	
<p>Write EC Notification: Yes</p> <p>FDA= Pole / Broken / Damaged / Replace</p> <p>Priority= A Tag, Follow the emergency process due to damage claim.</p>	

VEHICLE DAMAGE, TEMP REPAIRS MADE



At this Location: Pole damaged by vehicle. Cross-arm acting as Splint installed as temporary repair. Circumference of pole at base is 32 inches. Arc length of damage is 18 inches. (>40% circumference)



Perform Minor Work: No

Write 3rd Party Notification: No

Write EC Notification: Yes

FDA= Pole / Broken / Damaged / Replace

Priority= Minimum E Tag, depending on exposure

SIGNIFICANT REDUCED CIRCUMFERENCE (TRACTOR DAMAGE)



At this Location: Significant Reduced Circumference (Tractor Damage). Refer to reduction in cross-sectional area flow chart.



Perform Minor Work: No

Write 3rd Party Notification: No

Write EC Notification: Yes

FDA= Pole / Broken / Damage / Replace

Priority= Minimum E Tag, depending on exposure

CUT INTO POLE



At this Location: Cut into pole. Not a deep cut, no strain on pole, no public exposure. Refer to reduction in cross-sectional area flow chart above.



Perform Minor Work: No

Write 3rd Party Notification: No

Write EC Notification: Yes

FDA= Pole / Broken/Damaged / Replace

Priority= Minimum E Tag, depending on exposure



Reduced Circumference

General Guidance: Does pole have significant reduced circumference in the bottom ~8 feet? Circumference reduction should be more or less uniform (hourglass).

For example, animal, burnt, or shell rot. If uniform circumference loss is significant, inspector should measure the circumference. When measuring, measure the circumference of the healthy part of the pole nearest the damage minus the circumference of the damaged part of the pole. Divide the difference by the circumference of the healthy part of the pole.



$$\frac{(\text{circumference of healthy part}) - (\text{circumference of damage part})}{(\text{circumference of healthy part})} = \% \text{ circumference loss}$$



No Action	E Tag	X tag
0-10%	10-30%	>30%

Reference ATS 2325P-01





Examples

BURNT POLE	
	<p>At this Location:</p> <p>Pole is burnt. Scrape pole to ensure circumference is not impacted.</p> <p></p>
	<p>Perform Minor Work: No</p>
	<p>Write 3rd Party Notification: No</p>
	<p>Write EC Notification: No</p>

DAMAGE TO POLE FROM SPECIFIC EVENT	
	<p>At this Location:</p> <p>Pole has reduced circumference; healthy wood has 32 inches and damaged section has 27 inches. Pole= ~15% circumference reduction</p>
	 
	<p>Perform Minor Work: No</p>
	<p>Write 3rd Party Notification: No</p>
	<p>Write EC Notification: Yes</p> <p>FDA= Pole / Broken / Damaged / Replace</p> <p>Priority= Minimum E Tag, depending on exposure</p>



SIGNIFICANT REDUCED CIRCUMFERENCE (BEAR DAMAGE)	
	<p>At this Location: Significant Reduced Circumference (Bear Damage). Temporary Repairs made.</p> <p>   </p>
	<p>Perform Minor Work: No</p>
	<p>Write 3rd Party Notification: No</p>
	<p>Write EC Notification: Yes</p> <p>FDA= Pole / Broken / Damaged / Replace</p> <p>Priority= X Tag, depending on exposure</p>





Split (Vertical Separation)

General Guidance: Please refer to beginning of this Pole section.

Split at Communication Level, whole length or location near an equipment supporting structure.

A vertical “Check” is a normal process of wood pole drying out. See example below.

Examples

POLE SPLIT AT COMMUNICATION LEVEL	POLE CHECK
	
<p>At this Location: Pole split, can see daylight through pole at communication level. Joint pole.</p> 	<p>At this Location: Pole Check, structural integrity not compromised. Natural cracking on the pole. Not due to strain or loading.</p> 
<p>Perform Minor Work: No</p>	<p>Perform Minor Work: No</p>
<p>Write 3rd Party Notification: No</p>	<p>Write 3rd Party Notification: No</p>
<p>Write EC Notification: Yes FDA= Pole / Broken / Damaged / Replace Priority= B Tag, depending on exposure</p>	<p>Write EC Notification: No</p>

POLE SPLIT

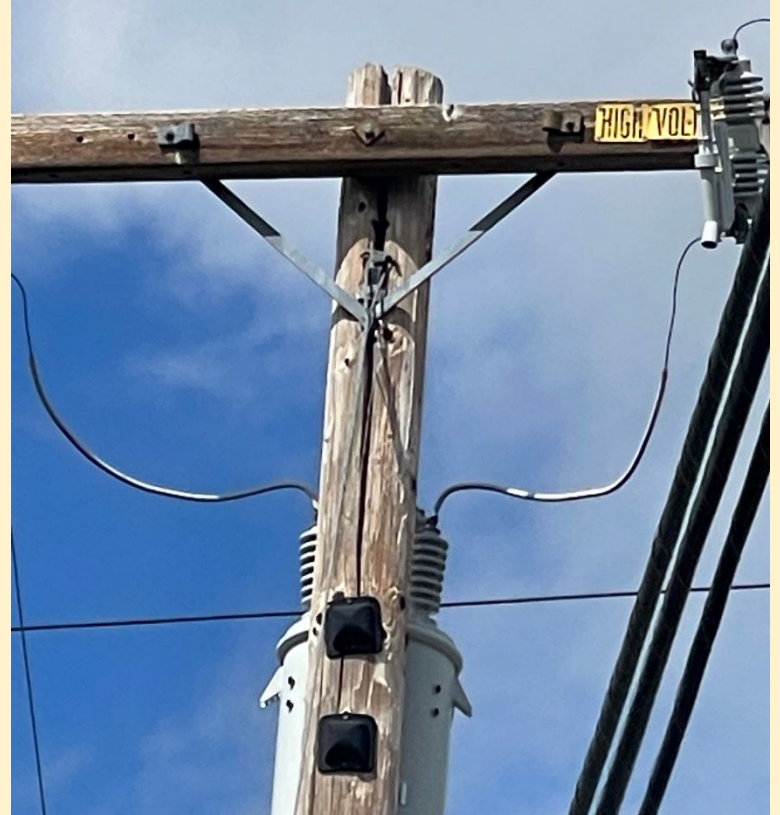

At this Location: Pole top split and can see daylight. Dead end single guy, down guy fixture has moved and slid down from original location onto the brace. Cross-arm brace hardware also compromised. No split bolt.



Perform Minor Work: No

Write 3rd Party Notification: No

Write EC Notification: Yes

FDA= Pole / Broken / Damaged / Replace

Priority= X Tag, depending on exposure.

POLE SPLIT



At this Location: Checks are opening on the pole at the equipment level. Multiple checks, possible movement on the cross-arm hardware, at the brace bolt on the top cross-arm. Hardware sinking in, pole twist spiral.



Perform Minor Work: No

Write 3rd Party Notification: No

Write EC Notification: Yes

FDA = Pole / Broken / Damaged / Replace

Priority = Minimum E Tag, depending on exposure

POLE SPLIT



At this Location: Split in the pole top has been corrected with a split bolt, but the dead end has moved and is laying on top of the split bolt.



Perform Minor Work: No

Write 3rd Party Notification: No

Write EC Notification: Yes

FDA = Pole / Broken / Damaged / Replace

Priority = Minimum E Tag, depending on exposure.

POLE CHECKS



At this Location: Pole Checks. Multiple vertical cracks running down pole are not at the points of attachment affecting the hardware. No compelling abnormal conditions to report.



Perform Minor Work: No

Write 3rd Party Notification: No

Write EC Notification: No

POLE CHECK



At this Location: Pole checks at the equipment level attachments but not affecting the hardware. Not a compelling abnormal condition.



Perform Minor Work: No

Write 3rd Party Notification: No

Write EC Notification: No

Overload (Bent)

General Guidance:

For deformed poles, follow the flow chart below to determine action.

Common drivers for deformed poles: Improper/lack of guying, third party attachment.

Review clearances to verify no reduced clearance issues, all levels of clearance requirements that could result in contact, fire risk, or public safety.

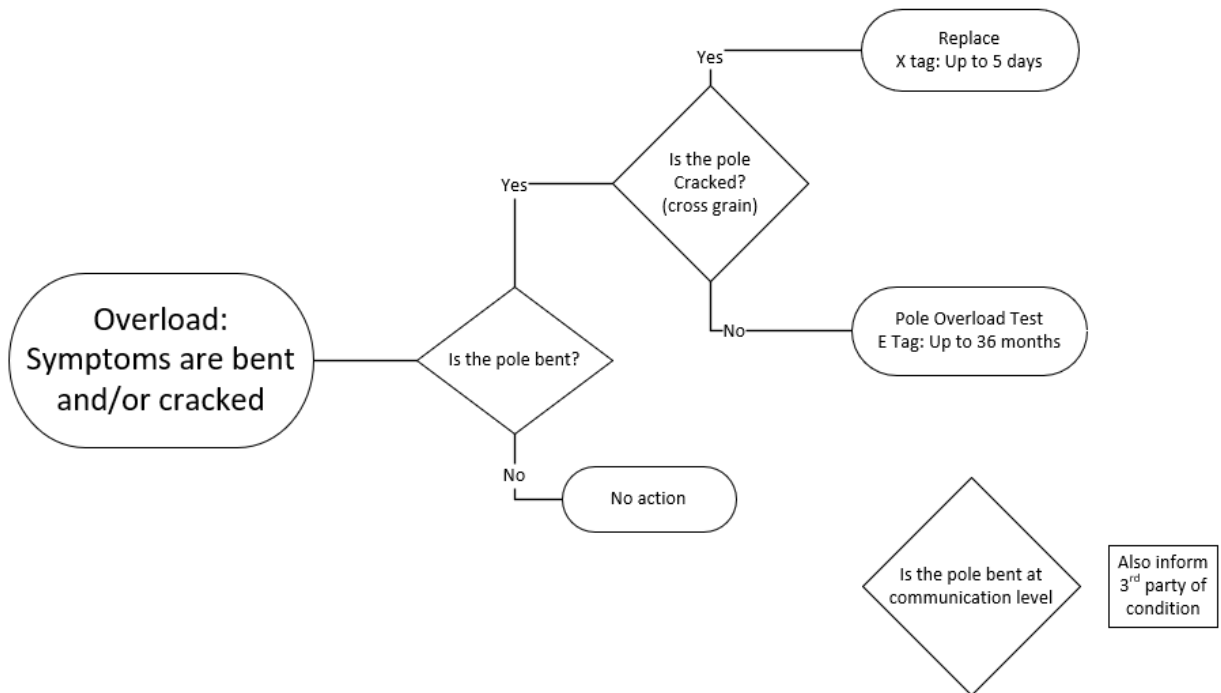



Minor Work: No

EC Notification: Follow flow chart.

Select the Priority and Due Date based upon compelling abnormal condition that may adversely impact public safety and/or service reliability.





Related Documents: [TD-2305M](#) EDPM Pole Inspection





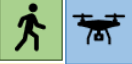

Examples

POLE BENT 4 FEET OUT OF LINE	
	<p>At this Location: Pole is bent 4 feet out of line and has horizontal crack. Deformed in the middle of the pole, towards vegetation.</p> <p> </p> <p>Perform Minor Work: No</p> <p>Write 3rd Party Notification: No</p> <p>Write EC Notification: Yes FDA= Pole/Broken/Damage/ Replace</p> <p>Priority= X Tag, depending on exposure</p>

INADEQUATE SUPPORT AT COMMUNICATIONS LEVEL	
	<p>At this Location: Pole is bent at communication level. No horizontal crack. Two guys stabilizing communication level.</p> <p> </p> <p>Perform Minor Work: No</p> <p>Write 3rd Party Notification: Yes</p> <p>Write EC Notification: Yes FDA= Pole / Overload / Test</p> <p>Priority= Minimum E Tag, depending on exposure. Note: Needs both EC and Third-Party notifications</p>



OVER STRESSED POLE	UNBALANCED LOAD AT TOP
	
<p>At this Location: Pole is twisted, cracked, due to communication. Field comments “overloaded by communications”. No horizontal crack.</p> 	<p>At this Location: Deformed pole with bowed top in line with conductor. No horizontal crack visible.</p> 
<p>Perform Minor Work: No</p>	<p>Perform Minor Work: No</p>
<p>Write 3rd Party Notification: Yes</p>	<p>Write 3rd Party Notification: No</p>
<p>Write EC Notification: Yes FDA= Pole / Overload / Test</p> <p>Priority= Minimum E Tag, depending on exposure.</p>	<p>Write EC Notification: Yes FDA= Pole / Overload / Test</p> <p>Priority= Minimum E Tag, depending on exposure.</p>

OVERLOAD BENT	
POLE BROKEN AT THE COMMUNICATION LEVEL	POLE BENT AT MIDDLE SECTION
	
<p>At this Location: Pole is bent and has horizontal crack. Pole broken at the communication level.</p> <p> </p>	<p>At this Location: Pole is bent, but not cracked. Broken pole, Supported by guy.</p> <p> </p>
<p>Perform Minor Work: No</p>	<p>Perform Minor Work: No</p>
<p>Write 3rd Party Notification: No</p>	<p>Write 3rd Party Notification: No</p>
<p>Write EC Notification: Yes FDA= Pole / Broken / Damaged / Replace Priority= X Tag</p>	<p>Write EC Notification: Yes FDA= Pole / Overload / Test Priority= Minimum E Tag, depending on exposure.</p>

POLE BENDING 3 POT TRANSFORMER IN BUCK POSITION



At this Location: Pole is leaning less than 10% out of plumb, bending in direction of offset equipment. Pole is not cracked.



Perform Minor Work: No

Write 3rd Party Notification: No

Write EC Notification: Yes





FDA= Pole / Overload / Test

Priority= Minimum E Tag, depending on exposure.

Decayed / Rotten

General Guidance: Please refer to beginning of this Pole section.

Examples

DECAY OF POLE OVER TIME	SEVERE DETERIORATION AT GROUND LEVEL
	
<p>At this Location: Pole top decayed</p> 	<p>At this Location: Deteriorated condition found during inspection. High public exposure.</p>  
<p>Perform Minor Work: No</p>	<p>Perform Minor Work: No</p>
<p>Write 3rd Party Notification: No</p>	<p>Write 3rd Party Notification: No</p>
<p>Write EC Notification: Yes FDA= Pole Decayed / Rotten / Replace Priority= B Tag, depending on exposure</p>	<p>Write EC Notification: Yes FDA= Pole Decayed / Rotten / Replace Priority= A Tag</p>

DECAY OF POLE OVER TIME – AERIAL VIEW



At this Location: Pole top decayed.



Perform Minor Work: No

Perform Minor Work: No

Write 3rd Party Notification: No

Write 3rd Party Notification: No

Write EC Notification: Yes

Write EC Notification: Yes

FDA= Pole Decayed/Rotten/Replace

FDA= Pole Decayed / Rotten / Replace

Priority= X Tag

Priority= B Tag, depending on exposure

DECAY OF POLE OVER TIME – AERIAL VIEW



At this Location: Pole top decayed.



Perform Minor Work: No

Write 3rd Party Notification: No

Write EC Notification: Yes

FDA= Pole Decayed/Rotten/Replace

Priority= Minimum E Tag, depending on exposure.

DECAYED POLE, MULTIPLE ISSUES	
	
<p>At this Location: Pole has multiple conditions: Pole in poor condition, decayed, and extensive weathering, and pole top rot. Pole checks alone are not a compelling abnormal condition, but in combination with all the other conditions, write EC tag.</p>	
<p>   </p>	
<p>Perform Minor Work: No</p>	
<p>Write 3rd Party Notification: No</p>	
<p>Write EC Notification: Yes FDA = Pole Decayed / Rotten / Replace Priority = Minimum E Tag, depending on exposure.</p>	



Woodpecker

General Guidance: Visually inspect poles for woodpecker damage based on the flow chart below.

- A through hole counts as two holes
- A filled hole is still considered a hole.
- Consider reframe instead of replacing where possible.

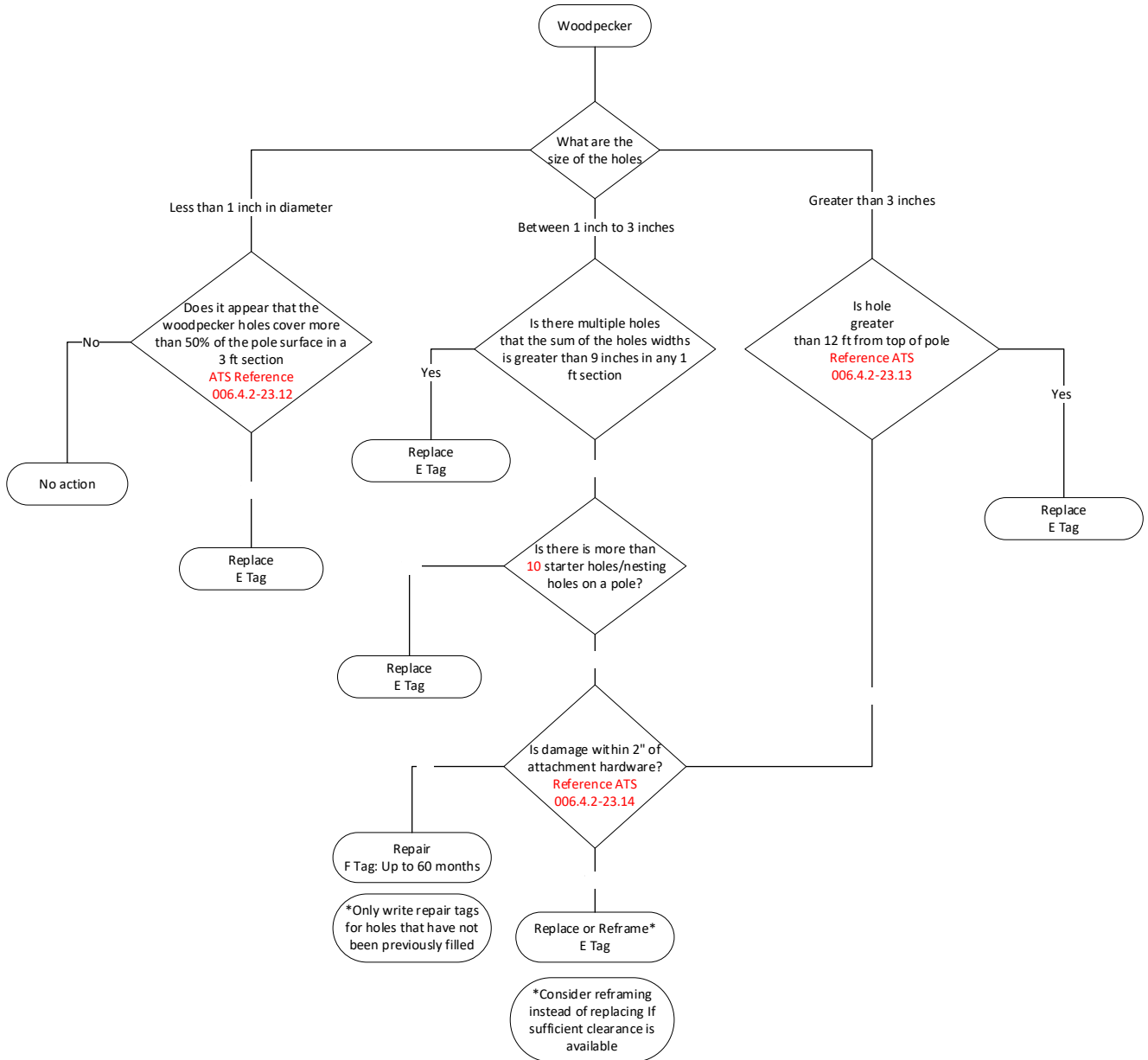



Minor Work: No

Write 3rd Party Notification: No

EC Notification: Refer to flow chart for EC priority.

Reference: [066209 – Repair of Damaged Pole Tops](#)

Per [066209](#):

Active Nests:



- Active Nests are ones with eggs or young in them.
- Do not disturb active nests unless they present an immediate safety or operating hazard.

Inactive Nests:

- Inactive nests are those nests without viable eggs or young.
- Inactive nests, except eagle nests or T&E (threatened and endangered) species' nests, can be removed; however, do not keep an inactive nest without notifying avian program management personnel or governmental agencies. Nests may be difficult to identify.

If there is any uncertainty about the type of nest, contact Lead / Supervisor or the avian program management personnel or the Bird Hotline at (415) 973-9453 for assistance with an active nest removal or relocation.

Examples

WOODPECKER DAMAGE <1 INCH HOLES	
	<p>At this Location: Holes are less than 1 inch in diameter and acorn/feeder holes cover more than 50% of the pole surface in a 3 ft section.</p> <p>   </p> <p>Perform Minor Work: No</p> <p>Write 3rd Party Notification: No</p> <p>Write EC Notification: Yes</p> <p>FDA= Pole / Woodpecker Damage / Replace</p> <p>Priority= Minimum E Tag, depending on exposure.</p>

WOODPECKER DAMAGE <1 INCH HOLES





At this Location: Holes are less than 1 inch in diameter and acorn/feeder holes do not cover more than 50% of the pole surface in a 3 ft section.







Perform Minor Work: No



Write 3rd Party Notification: No

Write EC Notification: No

WOODPECKER DAMAGE <1 INCH	
	<p>At this Location: Woodpecker hole less than 1 inch, damage is within 6 inches from top. Holes cover less than 50% of the pole surface in a 3 ft section.</p>
	
	<p>Perform Minor Work: No</p>
	<p>Write 3rd Party Notification: No</p>
<p>Write EC Notification: No</p>	

WOODPECKER DAMAGE 1-3 INCH HOLES	
	<p>At this Location: There are multiple holes that the sum of the holes widths is greater than 9 inches in any 1 ft section.</p>
	
	<p>Perform Minor Work: No</p>
	<p>Write 3rd Party Notification: No</p>
<p>Write EC Notification: Yes</p> <p>FDA= Pole / Woodpecker Damage / Replace</p> <p>Priority= Minimum E Tag, depending on exposure.</p>	

WOODPECKER DAMAGE 1-3 INCHES	
	<p>At this Location: The sum of the holes are less than 9 inches. Woodpecker holes are not within 2 inches from attachment hardware.</p> <p>   </p>
	<p>Perform Minor Work: No</p>
	<p>Write 3rd Party Notification: No</p>
	<p>Write EC Notification: Yes FDA= Pole / Woodpecker Damage / Repair Priority= F Tag, up to 5 years</p>

WOODPECKER DAMAGE 1-3 INCHES	
	<p>At this Location: The sum of the holes are less than 9 inches. Woodpecker holes are within 2 inches from attachment hardware.</p> <p>   </p>
	<p>Perform Minor Work: No</p>
	<p>Write 3rd Party Notification: No</p>
	<p>Write EC Notification: Yes FDA= Pole / Woodpecker Damage / Replace or Pole / Broken Damage / Reframe* Priority= Minimum E Tag, depending on exposure. Note: Inspector should use judgement on if pole can be reframed instead of replaced</p>

WOODPECKER DAMAGE 1-3 INCHES



At this Location: Single hole 1-3 inches within 2 inches from attachment hardware.



Perform Minor Work: No

Write 3rd Party Notification: No

Write EC Notification: Yes

FDA= Pole / Woodpecker Damage / Replace or Pole / Broken Damage / Reframe*

Priority= Minimum E Tag, depending on exposure.

Note: Inspector should use judgement on if pole can be reframed instead of replaced

WOODPECKER DAMAGE >3 INCHES



At this Location: Woodpecker hole is greater than 3 inches, less than 12 feet from top of pole, and within 2 inches from attachment hardware.



Perform Minor Work: No

Write 3rd Party Notification: No

Write EC Notification: Yes

FDA= Pole / Woodpecker Damage / Replace

Priority= Minimum E Tag, consider B Tag, due to size of hole and proximity to hardware

WOODPECKER DAMAGE NESTNG CAVITY

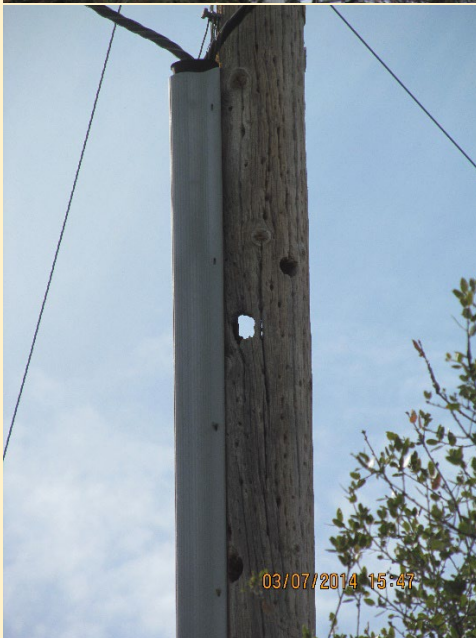

At this Location: A through hole counts as 2 holes. The 3 holes within a 1-foot section added together are greater than 9 inches.



Perform Minor Work: No

Write 3rd Party Notification: No

Write EC Notification: Yes

FDA= Pole / Woodpecker Damage / Replace

Priority= Minimum E Tag, consider B Tag, due to size of holes

The following are guidelines for repair of repair of woodpecker-damaged pole tops.

Reference: [066209 – Repair of Damaged Pole Tops](#)

Soil Excessively Eroded or Washed Away at Base of Pole

General Guidance: If the inspector notices that a large amount of soil was washed or eroded away at the base of a pole, consider writing an EC notification to investigate whether the pole still meets its designed set depth.

Related Documents: [015203](#), page 2, table 1

Example

SOIL ERODED AT BASE OF POLE	
	<p>At this Location: a large amount of soil was washed or eroded away at the base of a pole, Not leaning.</p> <div style="display: flex; align-items: center; gap: 5px;"> 🚶 🚁 </div> <p>Perform Minor Work: No</p> <p>Write 3rd Party Notification: No</p> <p>Write EC Notification: Yes</p> <p>FDA= Pole / Soil Eroded / Graded / Replace</p> <p>Priority= Minimum E Tag, depending on exposure.</p>



Transmission Poles and Distribution Underbuild

General Guidance: At minimum, when performing GO 165 patrols or inspections, Inspectors should perform a “patrol” of the transmission assets in the area being patrolled or inspected in order to identify any **obvious structural problems or hazards** that need to be addressed by the Transmission Organization. Review clearances to verify no reduced clearance issues, all levels of clearance requirements that could result in contact, fire risk, or public safety.

Note: Do not install distribution barcode on transmission poles

When in doubt call your supervisor or PG&E Lead

- Examples of the types of issues that could be identified:
- Damaged or broken poles
- Broken or decayed crossarms
- Broken insulators
- Damaged tie wire
- Vegetation issues



Minor Work: No

If you identify an obvious structural problem or hazard in the field that is NOT an emergency:

Write EC Notification: Yes

- Generate an EC to generate an LC.

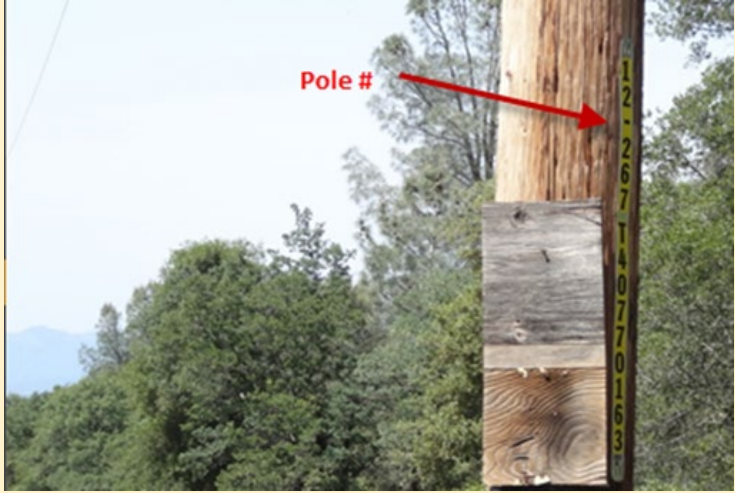
Example 1

TAKE PICTURE OF TRANSMISSION POLE	
	<p>In the process of creating the EC Notification, include a photo of the Transmission pole number.</p> <p> </p>

Example 2

A. Distribution riser on structure

General Guidance: Steel Transmission Structure with Distribution Underbuilds with **external** riser present. If observed, yes, create EC notification to relocate riser.



Note: Presents of distribution riser on steel transmission pole exposes customer equipment to transmission flashover voltages.

RISER ON STEEL TRANSMISSION POLE	
<p>At this Location: Steel Transmission Structure with Distribution underbuild with external riser on steel pole.</p>	
<p> </p>	
<p>Perform Minor Work: No</p>	
<p>Write 3rd Party Notification: No</p>	
<p>Write EC Notification: Yes</p> <p>FDA= Riser / Pothead / Installed in Error / Relocate</p> <p>Priority= Minimum E Tag, depending on exposure.</p>	

B. Distribution riser on structure

General Guidance: Structure must be steel Transmission Structure with Distribution Underbuilds with **internal riser** within steel pole. If observed, yes, create EC notification to relocate riser.

Note: Presents of distribution riser on steel transmission pole exposes customer equipment to transmission flashover voltages.



STEEL TRANSMISSION STRUCTURE WITH DISTRIBUTION UNDERBUILD WITH INTERNAL RISER WITHIN STEEL POLE	
	<p>At this Location: Steel Transmission Structure with Distribution underbuilds with internal riser within steel pole.</p> <div style="display: flex; align-items: center; gap: 10px;">   </div>
	<p>Perform Minor Work: No</p>
	<p>Write 3rd Party Notification: No</p>
	<p>Write EC Notification: Yes FDA= Riser / Pothead / Installed in Error / Relocate Priority= Minimum E Tag, depending on exposure.</p>

Example 3

Distribution transformer serving an external customer installed without a common neutral present.

General Guidance: If observed, yes, create EC notification to relocate the transformer.

Related Documents: [068177](#), G.O. 95 Rule 33B, [056425](#) (Note 1 on pg. 1 and sub-note 1 on bottom of pg. 1)

DISTRIBUTION TRANSFORMER ON STEEL TRANSMISSION POLE WITHOUT COMMON NEUTRAL	
	<p>At this Location: Distribution transformer on steel transmission pole without common neutral.</p> <p> </p> <p>Perform Minor Work: No</p> <p>Write 3rd Party Notification: No</p> <p>Write EC Notification: Yes FDA= Transformer / No Common Neutral / Relocate</p> <p>Priority= Minimum E Tag, depending on exposure.</p>

Example 4

Missing or Broken Distribution Bridging



General Guidance: If observed, yes, create EC notification to repair or install missing bridging.

Note: If bridging is not installed on a distribution wood cross-arm on a transmission wood pole, then create an EC tag to install bridging.

Related Documents: [TD-2305M-B009](#)

WOOD CROSSARM ON WOOD TRANSMISSION POLE WITH DISTRIBUTION UNDERBUILD BRIDGING	
	<p>Bridging Example</p> <div style="display: flex; gap: 10px;"> </div>



BURNT POLE DUE TO MISSING BRIDGING	
	<p>At this Location: Transmission pole with missing bridging on the distribution cross-arm, burnt pole, assess pole.</p> <p>   </p>
	<p>Perform Minor Work: No</p>
	<p>Write 3rd Party Notification: No</p>
	<p>Write EC Notification: Yes</p> <p>FDA= OH Facility / Transmission issue / Create LC</p> <p>Priority= B Tag, depending on exposure</p>



Solely Owned Poles with Third-Party Utility Attachments

General Guidance: Identify all solely owned pole with third-party attachments (based on how it is mapped). Initiate a map correction to indicate structure is mapped as solely owned but has utility attachment in the field.

Minor Work: No

EC Notification: No

Related Documents: [TD-2305M](#) EDPM Pole Inspection, [TD-2325S](#)

Intumescent Pole Covers

PG&E has added intumescent pole covers to slow or prevent fire damage to some wood poles in T3/T2 areas. The cover is introduced in Utility Bulletin: TD-015203-B005

Disclaimer: Intumescent pole covers are not a valid CGI condition. It is not the intent of PG&E to require a CGI EC Notification on intumescent covered poles unless the location, including vegetation, customer access, etc., meets the existing CGI conditions. as described in System Inspection's Training material and the Overhead Job Aid

- **Pole Damaged:**
 - You observe noticeable pole damage, even with the cover on the pole.
 - Examples may include overloads, woodpecker/animal/vehicle damage, and signs of broken/bent/leaning/split poles, etc.
 - Always create an EC Notification to repair/replace the damaged Hardware/Framing
 - **Suspect Pole and Cover Damaged:**
 - Any gaps of the cover larger than a tennis ball exposes the wood to fire damage.
 - Create an EC Notification to repair/replace the cover and to assess the pole for other possible damage.
 - **Note:** If authorized and trained to do so, you may cut away the cover allowing further inspection of the pole and then the cover can be reapplied. Patch pieces are available using Material code M140214.
- Intumescent Pole Covers Example:



Distribution Towers / Steel Lattice

General Guidance: You are required to record a distribution inspection for **structures carrying distribution voltage**. If transmission is on the same tower, inspect distribution components only. If no transmission on tower, inspect distribution components and notify supervisor to confirm that the tower inspection is in the transmission plan. Inspectors are required to inspect distribution towers / lattices for the following:

- Steel Covered by Earth
- Rust or Corrosion at Tower Footings
- Tower Footing Damaged
- Tower Member Loose
- Marking Hi-Sign Missing/Not Legible
- Guarding - Tower Not Guarded (Where Applicable)
- Guy Attachment, Turn Buckles, or Preformed Guys Loose
- Tower Rusty – Needs Paint

Minor Work: No

EC Notification: Yes

Related Documents: [022168](#)

Tree Attachments

Definition: A Tree Connect is a PG&E asset because the tree which is not owned by PG&E has one or more attachments connected to it.

PG&E Attachments may include:

- Primary Conductor
- Secondary Conductor
- Service Conductor
- Streetlight Conductor
- Hardware
- Anchor
- Guy Assemblies

General Guidance: As you perform a visual inspection of all associated conductor(s) from structure to midspan in all directions or to weather head or termination point in all directions, look for tree attachments (Mapped or Un Mapped).

The Ultimate Goal is to have all Tree Connects mapped, have an Orange Inspection Halo and record the Inspection of each Tree Connect using the Inspection Checklist.

Note: When performing an inspection for a tree connect, tree connects should be recorded as PG&E owned and not customer owned.

Minor Work: No

Related Documents: TD-2999B-044

Common Scenarios: Follow process for each:

- (1) Tree Connect is Mapped and has an Orange Inspection Halo (Complete inspection)

(a) **Reference:** Mapped tree symbol



- (2) Tree Connect is Mapped as a proposed Clearance Pole (Red dotted circle) With No Halo:

(a) Follow [Adhoc Inspection Process](#)

- (3) Tree Connect is Un-mapped:

(a) Follow [Adhoc Inspection Process](#)

- (4) Tree Connect is mapped but does not have an Orange Inspection Halo:

(a) Request Halo <mailto:SystemInspectionHaloIssues@pge.com>

- (5) Tree connect is mapped but does not exist in field:

(a) Complete inspection record indicating structure does not exist in field.



Tree Attachments Found in the Field Procedure

Identification by System Inspections:

- Assess the tree condition per Vegetation Management (VM) guidance provided in Job Aid, “Utility Bulletin TD-2999B-044, Guidance on Tree Health Priority Job Aid”.
- If tree is “**Green**” and considered to be in **Good Condition**, **NO EC is required**.
 - If open EC exists for location and field conditions are **NOT compelling** or **NOT a regulatory condition**, process cancellation request in accordance with [TD-2305M-JA13](#), “EC Job Aid: Create, Complete, Cancel EC Notifications”.
- **If an immediate hazard exists**, Create an **Emergency “A” Tag**.
 - **The location cannot be made safe to the public without additional Qualified Company Representative (QCR) support, the first responder *MUST* standby until relieved by the additional QCRs *OR* until the hazard has been made safe.**

Category	Priority	MAT	Wort Type Code	Tree Mortality
Emergency	A	17B	501	Dead or Dying OR Green

- Under **Item Details**, the **Facility Type / Damage / Action (FDA)** of notification should be:
 - Tree/Vine / Decayed/Rotten / Install CL Pole
- Notification **Cause** should be:

Object	Damage	Cause	Activity
Tree / Vine	Decayed / Rotten	Tree Contact	Install CL Pole

- Tree Contact



- If tree is “Dead or Dying” or “Green” and considered to **NOT be in Good Condition**, Create **EC Replacement Tag**, based on field conditions:

Category	Priority	MAT	Wort Type Code	Tree Mortality
EC	B or E	07C	311C	Dead or Dying OR Green

- **EC “B” or “E” Tags:**
 - Under **Item Details**, the **Facility Type / Damage / Action (FDA)** of notification should
 - Tree/Vine / Decayed/Rotten / Install CL Pole

Object	Damage	Activity
Tree / Vine	Decayed / Rotten	Install CL Pole

- If open EC exists for location and field conditions warrant an expedited Priority, update Pending EC as appropriate.
- If tree condition cannot be adequately assessed, Create an **EC Assessment Tag** for VM Review:

Category	Priority	MAT	Wort Type Code	Tree Mortality
EC	B	07A	311A	Dead or Dying OR Green

- **The EC Assessment Tag MUST ONLY have the designated FDA for Tree Assessment.**
- Under **Item Details**, the **Facility Type / Damage / Action (FDA)** of notification should be:
 - Tree/Vine / Tree Connect / Assessment

Object	Damage	Activity
Tree / Vine	Tree Connect	Assessment

TREE CONNECTS



At this Location: Tier 3 area, tree connect on dead/dying tree; attachments are solid.



Perform Minor Work: No

Write 3rd Party Notification: No

Write Veg Form:



Write EC Notification: Yes

FDA= Tree/Vine / Decayed/Rotten / Install Clearance Pole

Priority= E Tag, 3-6 months, depending on exposure



Examples

TREE CONNECT ON DEAD/DYING TREE	
	<p>At this Location: Tier 2 area, tree connect on dead/dying tree with multiple woodpecker holes and damaged primary insulators.</p> <div style="display: flex; align-items: center;">   </div>
	<p>Perform Minor Work: No</p>
	<p>Write 3rd Party Notification: No</p>
	<p>Write Vegetation Notification: No</p>
	<p>Write EC Notification: Yes</p> <p>FDA= Tree/Vine / Decayed/Rotten / Install Clearance Pole</p> <p>Priority= X Tag</p>

Buddy Pole

Buddy Pole: A short section of pole, cut above and below the communication facilities, which are not being transferred to the new pole, and supported entirely by connections to the new pole.

Cut-and-kick: The wood pole replacement process where a new pole is placed in the same hole as the old pole and the old pole is temporarily secured to the new pole.

General Guidance: If there is a compelling abnormal condition (e.g., buddy pole not properly supported), then write EC notification. When in doubt call your supervisor or PG&E Lead

Minor Work: No



3rd Party Notification: No

EC Notification: Yes

Select the Priority and Due Date based upon compelling abnormal condition that may adversely impact public safety and/or service reliability.

Related Documents: [TD-2326P-01](#), [TD-2326P-01-JA01](#)

Example

BUDDY POLE	
	<p>At this Location: Buddy pole is properly supported.</p> <div style="display: flex; gap: 10px;">   </div>
	<p>Perform Minor Work: No</p>
	<p>Write 3rd Party Notification: No</p>
	<p>Write EC Notification: No</p>



Equipment

Oil-filled Equipment

Equipment Oil: Leaking/Weeping Stain

General Guidance: Refer to TD-2305M EDPM Manual - Assessments and Notifications Section for additional information about addressing oil in the field.

IF you observe a **stain or leak**

THEN (1) Look for **exposure or contamination**.

Refer to the PCB Spill/Leak Category Response Matrix to determine the appropriate action and priority.

- **Field employees must comply with the oil spill matrix table for how to handle oil conditions. Field employees should use the oil “indicator” language from the oil spill matrix table to describe the oil condition in the comments of the EC notification.**

Reminders:

- The field employee must create an emergency notification if the table directs creation of an A tag.
- If an Inspector identifies the emergency condition, they must create the A tag (do not wait for responder to create the A tag).
- WHEN the table directs you to contact EFS, the field employee must provide information and photos for EFS to make an informed decision.
- If identified after working hours, contact Environment Emergency Hotline, 1-800-874-4043.
- The field employee must note results of discussion with EFS in the notification:
 - Name of EFS
 - Guidance from EFS
- If you are unsure how to handle an oil condition, contact your supervisor or lead for guidance.

Minor Work: No

EC Notification: Yes

Related Documents: [TD-2320P-01, Attachment 1 - PCB Spill/Leak Category Response Matrix for Overhead, Sub-Surface, and Padmount Equipment](#)



PCB Spill/Leak Category Response Matrix – Overhead & Sub-Surface Equipment

Indicator	PCB Equipment Manufactured Before July 1979		Non-PCB Equipment Manufactured July 1979 or later	
	EC Notification Priority	Standby at Site	EC Notification Priority	Standby at Site
Equipment has failed and insulating fluid has run off the surface of the equipment and is in contact with the soil, vegetation, or water.	A Replace	Yes	A Replace	Yes
Insulating fluid has run off the surface of the equipment and is in contact with the soil, vegetation, or water OR Insulating fluid is actively dripping.	A Replace	Yes	A Replace	Supervisor discusses with EFS to determine a need to standby based on the location and size of spill.
Insulating fluid is about to run off the surface of the equipment but has not made contact with the soil, vegetation, water, or structure.	A Replace	Yes	A Replace	Supervisor discusses with EFS to determine a need to standby based on the location and size of spill.



PCB Spill/Leak Category Response Matrix – Overhead & Sub-Surface Equipment (continued)

Indicator	PCB Equipment Manufactured Before July 1979		Non-PCB Equipment Manufactured July 1979 or later	
	EC Notification Priority	Standby at Site	EC Notification Priority	Standby at Site
Insulating fluid is on the surface of the equipment and is not about to run off the surface and has sheen (Weeps or Seeps).	Supervisor discusses with EFS to determine EC notification category based on sensitivity of location and upcoming weather.			
	Sensitive Areas	A Replace	Not needed	B 3 Month Recheck • Describe sheen in notification • Re-check in 3 months.
	Non-sensitive Areas	B 30 day Replace IF estimating cannot be completed in time to meet 30 day deadline, THEN replace with like.		
Residual stain is a mark on the equipment that appears dried. Examples: • Stain on side of overhead transformer • Stain on concrete	No further action needed		Not needed	No further action needed

Example

LEAKING OH TRANSFORMER	
	<p>At this Location: Leaking OH Transformer, Residual Stain mark that appears dried, no sign of oil on ground. Oil has leaked out of the high side bushing, appears dried.</p> <p>   </p> <p>Perform Minor Work: No</p> <p>Write 3rd Party Notification: No</p> <p>Write EC Notification: No No further action</p>
LEAKING OH TRANSFORMER	
	<p>At this Location: Leaking OH Transformer, Residual Stain mark that appears dried on IFD (Internal Fault Detection)</p> <p>   </p> <p>Perform Minor Work: No</p> <p>Write 3rd Party Notification: No</p> <p>Write EC Notification: No No further action</p>

LEAKING OH TRANSFORMER, OIL ON THE GROND



AFTER - Taped off, cleaning measures applied, stand by still

At this Location: Leaking OH transformer, oil on the ground.



Perform Minor Work: No

Write 3rd Party Notification: No

Write EC Notification: Yes

FDA= Transformer / Leaking / Seeping / Replace

Priority= A Tag, follow the emergency process



Corrosion

General Guidance: In many parts of PGE’s service territory, facilities are exposed to conditions that both cause and accelerate corrosion of metal components.

During detailed inspections, examine facilities and assess their condition for corrosion. If corrosion is minor, repairs to the protective coatings that cover the metal surfaces on the equipment should be made. In addition, during the diagnostic testing for specific types of distribution line equipment, perform an examination for corrosion.

Minor Work: Yes

EC Notification: Yes, if compelling

Select the Priority and Due Date based upon compelling abnormal condition that may adversely impact public safety and/or service reliability.

IF you observe corrosion:

THEN:

- I. Look for exposure.
- II. Refer to the below table for to determine the corrosion rating and the required actions to perform. Visual examples follow:

Description	Symptoms	Required Actions
Integrity is breached	Hole(s) in metal (public exposure to High Voltage, Cover not securable, significant oil leak or spill, etc..)	EC notification Priority A or X - replace immediately or make safe and issue Priority B - Replace/Repair
Metal is damaged	Separation, layering, bubbling	EC notification Priority E - replace/repair.
Moderate to little or no corrosion	No sight of metal degradation, Discolored paint, staining	Inspect at next interval. No action required

Examples

OH CORROSION	
	<p>At this Location: Corrosion Weakening Integrity of Tank. Metal is separating into layers. Corrosion will breach tank.</p> <div style="display: flex; gap: 5px;"> </div> <p>Perform Minor Work: No</p> <p>Write 3rd Party Notification: No</p> <p>Write EC Notification: Yes FDA= Transformer / Corroded / Replace</p> <p>Priority= Minimum E Tag, depending upon exposure</p>

TRANSFORMER CORROSION



Picture from ground



Close up Picture

At this Location: Transformer with heavy corrosion has breached integrity of tank. Hole in lid of tank.



Perform Minor Work: No

Write 3rd Party Notification: No

Write EC Notification: Yes

FDA = Transformer / Corroded / Replace

Priority = Minimum X Tag, depending on exposure.





Internal Fault Device Activated

General Guidance: Is the Internal Fault Device activated (overheated) on the transformer (orange band is visible).

Minor Work: No

Related Documents: N/A

Example

TRANSFORMER INTERNAL FAULT DEVICE ACTIVATED	
	
Not Activated	Activated
<p>At this Location: Transformer internal fault device activated, indicating overheating, and the orange band is visible. Not to be confused with pressure relief valve.</p> <p> </p>	
<p>Perform Minor Work: No</p>	
<p>Write 3rd Party Notification: No</p>	
<p>Write EC Notification: Yes</p> <p>FDA= Transformer / Broken / Damaged / Replace</p> <p>Priority= E Tag</p>	



Transformer – Parallel

Is there an obvious paralleled transformer condition at this location? If yes, create EC notification to address parallel condition in the field. Priority should be F Tag, 60 months.

Minor Work: No

Related Documents: N/A

General Guidance: Use a combination of the mapping symbols and the actual field observations to properly assess the condition.

Examples

Banked transformers on separate poles should be identified as banked.

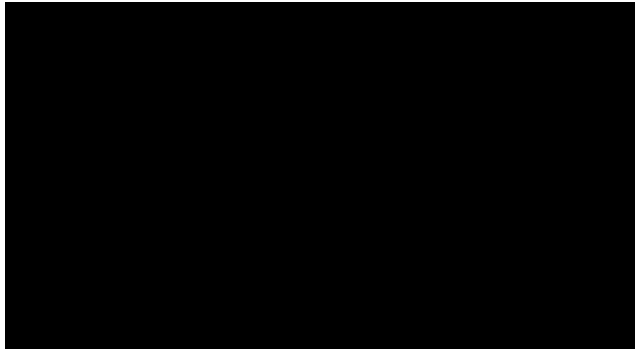

OH Paralleled Transformers

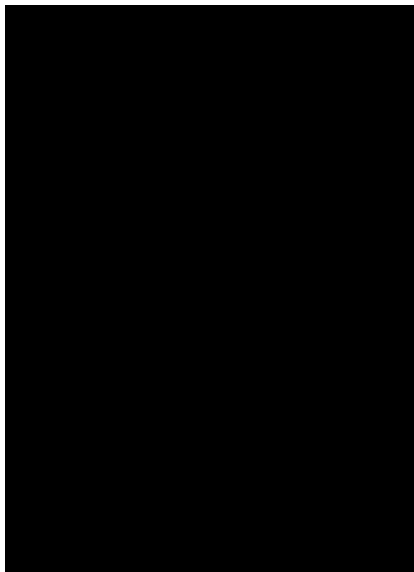



OH Transformers separated by bobs are ok



Transformer Bushings

General Guidance: Does the transformer have primary and/or secondary bushings and/or terminations damaged or broken? If so, write EC notification.

Examples

FLASHED INSULATOR ON TRANSFORMER

<p>At this Location: Flashed insulator on transformer</p> <div style="display: flex; align-items: center; gap: 10px;">   </div>
<p>Perform Minor Work: No</p>
<p>Write 3rd Party Notification: No</p>
<p>Write EC Notification: Yes FDA= Transformer / Flashed / Replace</p>
<p>Priority= E Tag, depending upon exposure</p>



SmartMeter / SCADA Equipment / Other Equipment on Poles

Broken/Damaged SmartMeter Relay/Access Point/Data Collector Unit or SCADA Equipment

General Guidance: If, through visual inspection, an inspector sees broken or damaged SmartMeter, antenna, DCU, or SCADA equipment, create EC notification. Be sure to check the SmartMeter box on the EC Form. If visible, note the operating number and/or serial number of the equipment.





Supervisors will contact SmartMeter and/or Operations to notify them of the issue and **determine EC or COE.**

Minor Work: No

EC Notification: Yes, unless COE

Related Documents: [072145](#), [072150](#), [068190](#), [054421](#)

Examples

EXAMPLES	
	
ANTENNA	CONTROL BOX ON STEEL TOWER
 	
PG&E WEATHER STATION	CONTROL BOX ON WOOD POLE



Switch Handle/Control Box is Not Locked

General Guidance: Ensure that boxes or enclosures located 8 feet or less above the ground are locked.

Minor Work: Yes

- Perform minor work if possible and if safe to do so.
- IF not able to perform minor work, THEN create EC notification.

EC Notification: Yes, only if not able to perform minor work.

Select the Priority and Due Date based upon compelling abnormal condition that may adversely impact public safety and/or service reliability.

Related Documents: [066195](#)

Surge “Lightning” Arrestors

Broken or Flashed

General Guidance: Are arrestors broken, damaged, flashed, or is the ground lead disconnect activated? If yes, Create EC notification to replace lightning arrestor.





Minor Work: No

EC Notification: Yes

Select the Priority and Due Date based upon compelling abnormal condition that may adversely impact public safety and/or service reliability.

Related Documents: [031822](#)

Examples

NON-EXEMPT SURGE ARRESTOR BLOWN	EXEMPT ABB-TYPE ARRESTOR BLOWN
	
<p>At this Location: Non-Exempt Surge Arrester Blown</p> 	<p>At this Location: Exempt ABB arrester operated / blown indicated by the orange marker sticking out the bottom.</p> 
<p>Perform Minor Work: No</p>	<p>Perform Minor Work: No</p>
<p>Write 3rd Party Notification: No</p>	<p>Write 3rd Party Notification: No</p>
<p>Write EC Notification: Yes FDA= Lightning Arrester / Broken / Damaged / Replace Priority= E Tag, depending on exposure</p>	<p>Write EC Notification: Yes FDA= Lightning Arrester / Broken / Damaged / Replace Priority= E Tag, depending on exposure</p>

Loose Hardware

General Guidance: Loose hardware involving cutouts. Arm loose/deteriorated causing the cutouts to almost be in underslung position.

Examples

LOOSE HARDWARE	
	<p>At this Location: Loose hardware involving cutouts. Arm loose/deteriorated causing the cutouts to almost be in underslung position.</p>
	<p>Perform Minor Work: No</p>
	<p>Write 3rd Party Notification: No</p>
	<p>Write EC Notification: Yes</p> <p>FDA: Hardware / Loose / Adjust</p> <p>Priority: E Tag, depending on exposure.</p>



Conductor

Bare Primary & Secondary Conductor

Part 1

Category 1 – Conductor visual assessment

General Guidance: Visually check all conductors (primary/secondary/service), associated attachments and dead-ends for damage from the structure being inspected to mid-span in all directions or the weather-head or to the conductor's termination point.

1. Primary, secondary, and/or service conductors that are broken, damaged, burnt, corroded, loose, frayed or bird caging.



- **General Guidance:** If observed, create EC Notification to repair or replace the conductor.



Note: If conductor has 30% or more of strands broken or if steel core in ACSR is broken, these are A Tag stand by situations.

A. Does the conductor have broken strands?

1. (No) No Action
2. (Yes) Strands broken within 2" of hardware interface.
 - a. (Yes) >30% strands visibly broken?
 - i. (Yes) Repair/Replace Level IA or IIX
 - ii. (No) Repair/Replace E Tag
 - b. (No) >30% strands broken?
 - i. (No) Repair/Replace E Tag
 - ii. (Yes) Repair/Replace Level 1A or IIX.

Examples

GUN SHOT DAMAGE	
	<p>At this Location: More than 30% broken strands.</p> <p> </p>
	<p>Perform Minor Work: No</p>
	<p>Write 3rd Party Notification: No</p>
	<p>Write EC Notification: Yes</p>
	<p>FDA: FDA = Conductor / Broken / Damaged / Repair or Replace</p> <p>Priority: A Tag or X Tag depending on exposure.</p>

BROKEN STRANDS	
	
<p>At this Location: Damage to the conductor, more than 30% broken strands</p> <p> </p>	
<p>Perform Minor Work: No</p>	
<p>Write 3rd Party Notification: No</p>	
<p>Write EC Notification: Yes</p> <p>FDA = Conductor / Broken / Damaged / Repair or Replace</p> <p>Priority = A Tag or X Tag depending on exposure.</p>	

BROKEN STRANDS UNDER VIBRATION DAMPER

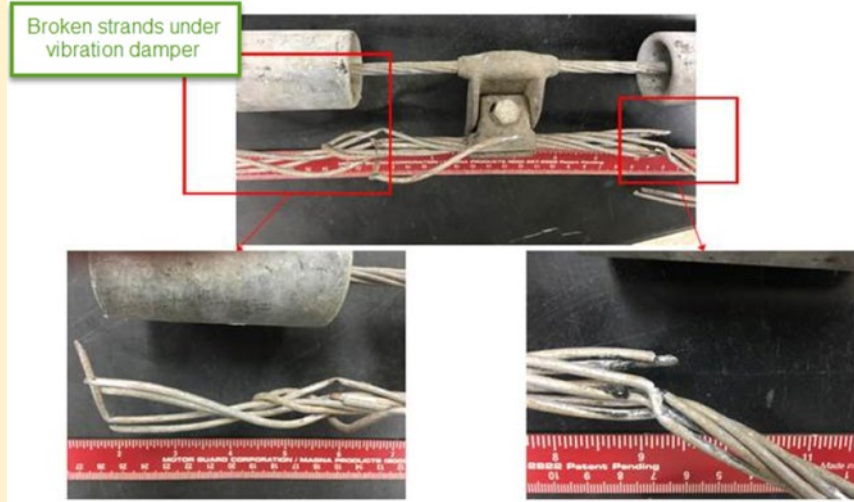

At this Location: Broken strands (more than 30%) under vibration Damper



Perform Minor Work: No

Write 3rd Party Notification: No

Write EC Notification: Yes

FDA = Conductor / Broken / Damaged / Replace

Priority = A Tag, follow emergency process or X Tag

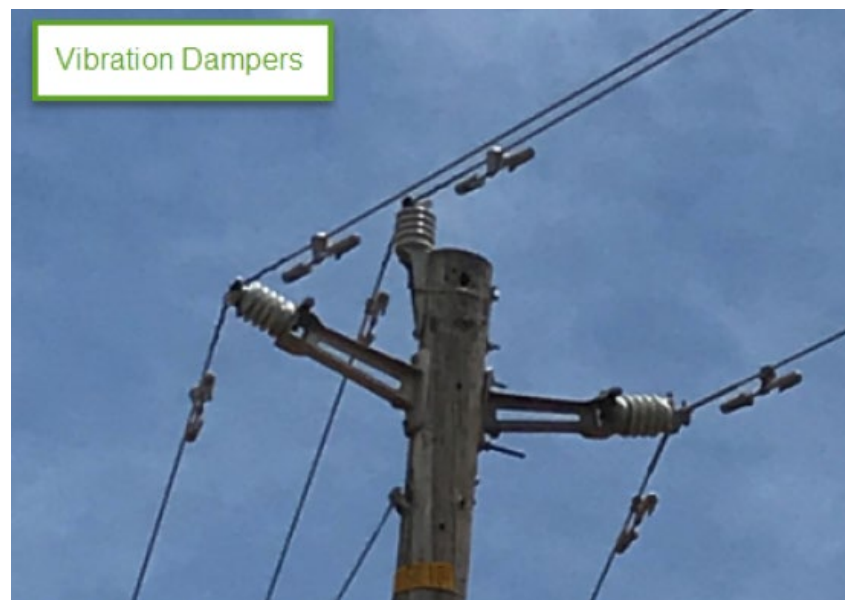

Vibration Damper



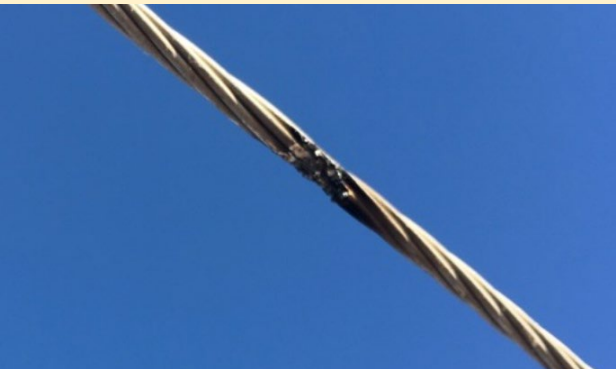

B. Is arc damage present?

1. (No) No action
2. (Yes) Does arched conductor have broken strand(s) or reduced cross sectional area?
 - a. (No) No action
 - b. (Yes) Is solid conductor?
 - i. (No) Repair/Replace E Tag
 - ii. (Yes) Repair/Replace E Tag

Examples

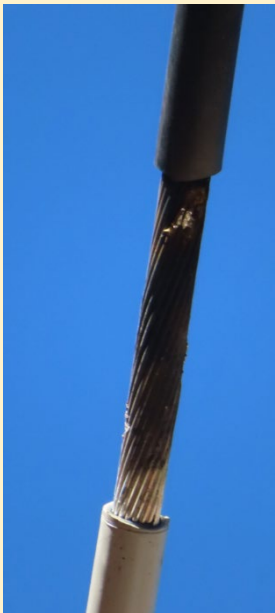
BURNT CONDUCTOR PRIMARY OR SECONDARY	
	<p>At this Location: Burnt Conductor, midspan, primary or secondary.</p> <div style="display: flex; gap: 10px;">   </div>
	<p>Perform Minor Work: No</p>
	<p>Write 3rd Party Notification: No</p>
	<p>Write EC Notification: Yes</p>
	<p>FDA: FDA = Conductor / Burnt / Repair or Replace</p> <p>Priority: E Tag, depending on exposure</p>

EXPOSED PRIMARY COVERED CONDUCTOR TREE WIRE, BURNT CONDUCTOR	
	<p>At this Location: Tree Wire conductor exposed and burnt, loss of cross-sectional area.</p> <div style="display: flex; align-items: center; gap: 10px;">   </div>
	<p>Perform Minor Work: No</p>
	<p>Write 3rd Party Notification: No</p>
	<p>Write EC Notification: Yes</p> <p>FDA= Tree Wire / Exposed / Repair</p> <p>FDA= Conductor / Burnt / Repair</p> <p>Priority: E Tag, depending on exposure</p>



C. Is conductor corroded?



1. (No) No action
2. Broken strands present?
 - a. (Yes) See, "Does the conductor have broken strands?"
 - b. (No) No Action
3. Arc Damage present?
 - a. (Yes) See, "Is arc damage present."
 - b. (No) No action

D. Does the conductor have excessive bird caging?

1. (No) No Action
2. (Yes) Is conductor under tension?
 - a. (No) No action
 - b. (Yes) Repair/Replace E Tag

Examples

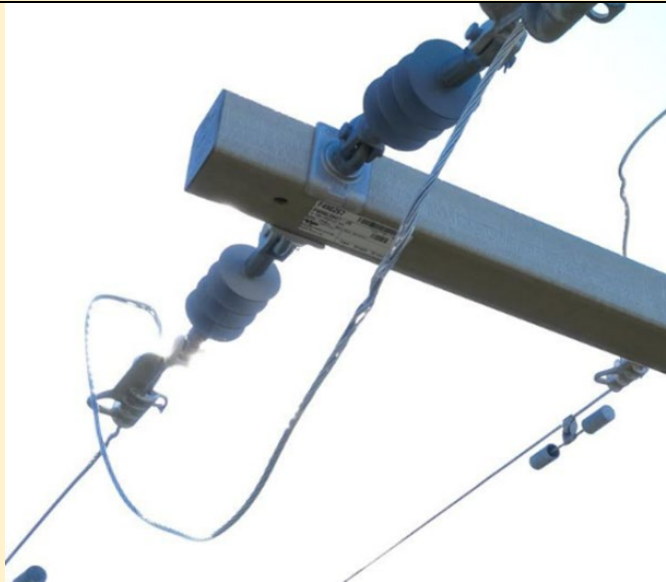
EXCESSIVE BIRD CAGING	
	<p>At this Location: Conductor has excessive bird caging.</p> <p> </p>
	<p>Perform Minor Work: No</p>
	<p>Write 3rd Party Notification: No</p>
	<p>Write EC Notification: Yes</p> <p>FDA: FDA = Conductor / Broken / Damaged / Repair or Replace</p> <p>Priority: E Tag, depending on exposure</p>

BIRD CAGING ON JUMPER NOT UNDER TENSION	
	<p>At this Location: Bird caging on jumper not under tension.</p> <p> </p>
	<p>Perform Minor Work: No</p>
	<p>Write 3rd Party Notification: No</p>
	<p>Write EC Notification: No</p>

BIRD CAGING GUY WIRE

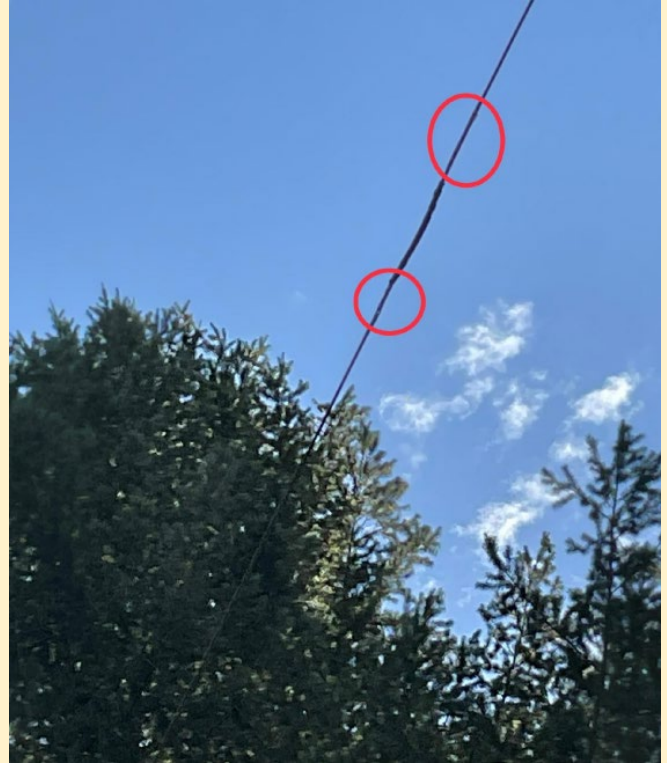

At this Location: Bird caging guy wire





Perform Minor Work: No



Write 3rd Party Notification: No

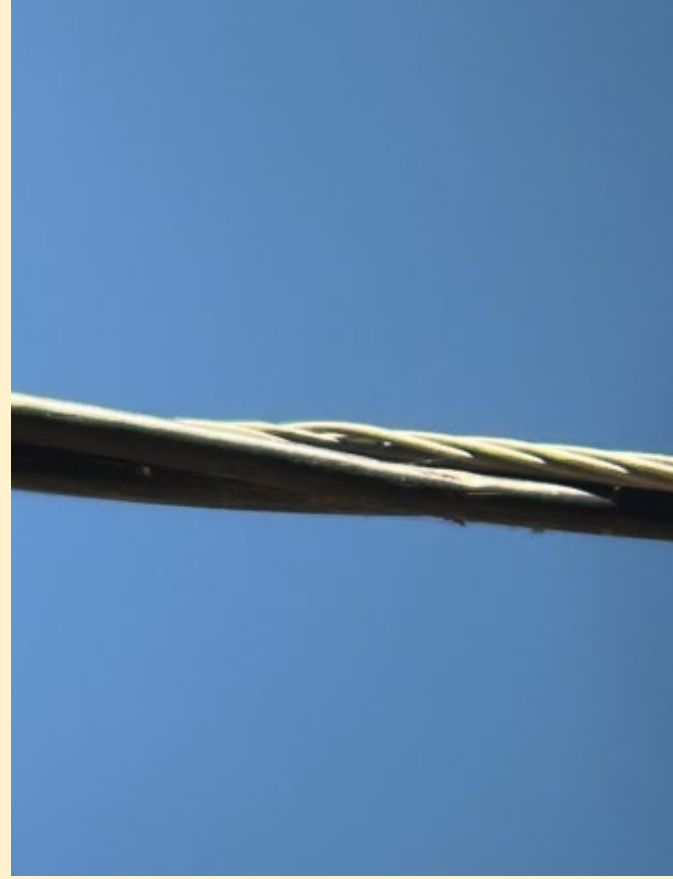

Write EC Notification: No



BIRD CAGING SERVICE NEUTRAL	
	<p>At this Location: Bird caging on service neutral. Not excessive bird caging.</p> <p> </p>
	<p>Perform Minor Work: No</p>
	<p>Write 3rd Party Notification: No</p>
	<p>Write EC Notification: No</p>



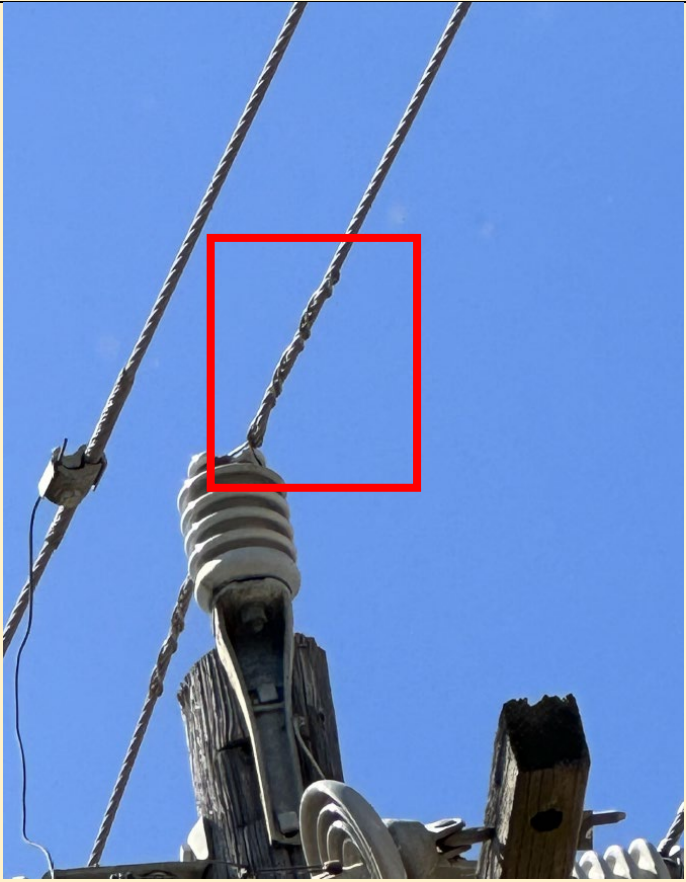

BIRD CAGING ON ARMOR ROD NON-COMPELLING	
	<p>At this Location: Bird caging on armor rod. Not excessive.</p> <div style="display: flex; justify-content: center; gap: 10px;">   </div>
	Perform Minor Work: No
	Write 3rd Party Notification: No
	Write EC Notification: No

BIRD CAGING NON-COMPELLING	
	At this Location: Bird caging non-compelling.  
	Perform Minor Work: No
	Write 3rd Party Notification: No
	Write EC Notification: No

E. Is there cracked AWAC conductor? Or localized corrosion on lashing or neutral conductor interfaces? (Secondary)

1. (No) No action
2. (Yes) Is hot leg exposed?
 - a. (No) Repair/Replace Level IIX
 - b. (Yes) Repair/Replace Level IA

CRACKED SERVICE	
	<p>At this Location: Corrosion, lashing is fused to conductor, hot leg is clearly exposed.</p>
	<p> </p>
	<p>Perform Minor Work: No</p>
	<p>Write 3rd Party Notification: No</p>
	<p>Write EC Notification: Yes</p> <p>FDA= Conductor Damaged / Replace</p> <p>Priority = A Tag, follow the emergency process.</p>

Category 2 – Connector/jumper visual assessment



Visually check for excessively corroded or damaged connectors and dead-end hardware which has a potential to fail, drop conductor, or cause an ignition.

- **General Guidance:** If observed, create EC Notification to replace connectors or dead-end hardware

F. Is the splice/connector damaged, corroded or cracked?

1. (No) No Action
2. (Yes) Repair/Replace E Tag

Example

DAMAGED, CORRODED, OR CRACKED SPLICES	
	<p>At this Location: Cracked Splice</p> 
	<p>Perform Minor Work: No</p>
	<p>Write 3rd Party Notification: No</p>
	<p>Write EC Notification: Yes</p> <p>FDA=Conductor / Broken Splice / Damaged / Replace</p> <p>Priority = E tag, depending on exposure</p>

G. Is the insulation tape on connector deteriorating?

1. (No) No Action
2. (Yes) Repair/Replace E Tag

Example

CONNECTOR WITH DETERIORATED TAPE	
	<p>At this Location: Deteriorated tape insulation, potential cross-phasing</p> <div style="display: flex; align-items: center; gap: 10px;">   </div>
	<p>Perform Minor Work: No</p>
	<p>Write 3rd Party Notification: No</p>
	<p>Write EC Notification: Yes</p> <p>FDA= Connector/ Insulation Deteriorated / Repair</p> <p>Priority = E Tag, depending on exposure</p>



H. Is the jumper frayed and/or burnt?

1. (No) No Action
2. (Yes) Repair/Replace E Tag

Examples

BURT JUMPER



At this Location: Primary jumpers and / or transformer secondary connection jumpers frayed and burnt. Insulation showing signs of deforming.



Perform Minor Work: No

Write 3rd Party Notification: No

Write EC Notification: Yes

FDA = Jumper / Burnt / Replaced

Priority = E Tag, depending on exposure



Category 3 – Loose Primary Neutral Ground





Look for broken service neutrals, or signs that the neutral is in poor condition i.e., damaged, burnt, loose, corroded, showing signs of wearing and about to fail. Conductor separation issues.

General Guidance: Use binoculars. If observed, Create EC to repair or replace conductor

I. Is the primary neutral/ground unsupported or hanging?

1. (No) No Action
2. (Yes) Repair/Replace Level II: up to 6 months.

Example

LOOSE PRIMARY NEUTRAL GROUND	
	
<p>At this Location: Loose primary neutral ground run, unsupported conductor, hanging.</p> 	<p>At this Location: Loose primary neutral ground run, unsupported conductor, hanging.</p> 
Perform Minor Work: No	Perform Minor Work: No
Write 3rd Party Notification: No	Write 3rd Party Notification: No
<p>Write EC Notification: Yes</p> <p>FDA = Molding, Loose, Adjust</p> <p>Priority = B Tag, depending on exposure</p>	<p>Write EC Notification: Yes</p> <p>FDA = Molding, Loose, Adjust</p> <p>Priority = B Tag, depending on exposure</p>



Category 4- Incorrectly installed splices/connectors

Are secondary connectors (mini wedge and Insulink) installed on primary conductor?

Guidance: If yes, write EC notification to replace connector.

J. Are secondary connectors installed on primary?

1. (No) No Action
2. (Yes) Repair/Replace F Tag

Example

SECONDARY CONNECTOR INSTALLED ON PRIMARY

At this Location: Secondary connector installed on primary.



Perform Minor Work: No

Write 3rd Party Notification: No

Write EC Notification: Yes

FDA: Connector / Incorrectly Installed / Replace

Priority: F Tag, depending on exposure

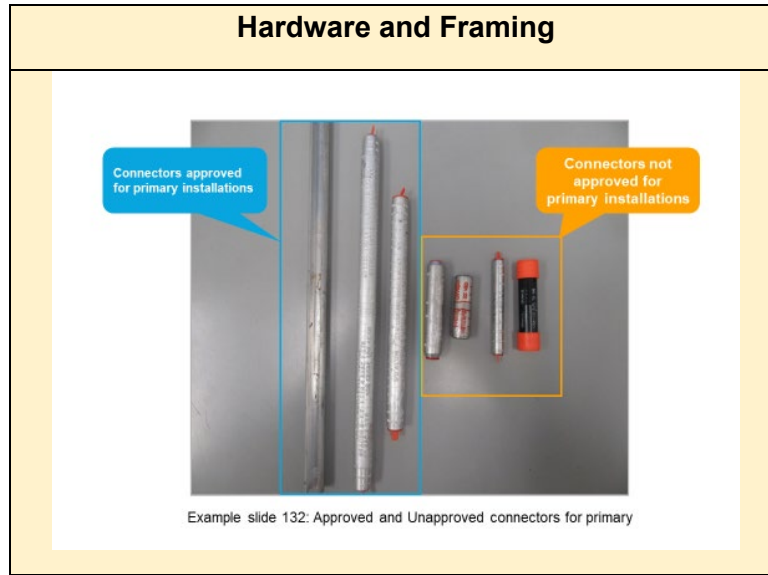

Wedge Connectors

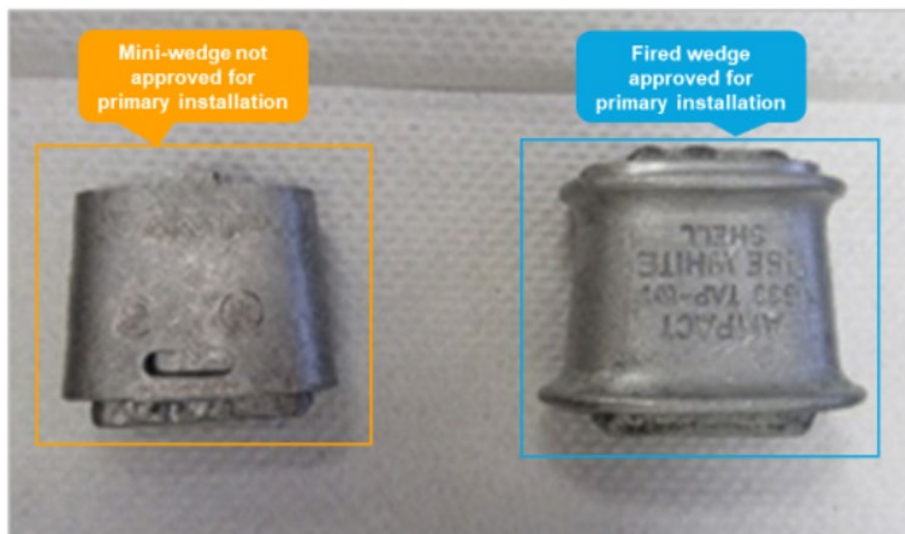

Example slide 132: Approved and Unapproved connectors for primary.



Are tap clamps installed incorrectly?

Guidance: If yes, write EC notification to replace connector.

- a. Identify improperly installed tap clamps (aka chance clamps); e.g.
 - i. Installed on armor rod (used for tying in conductor with hand ties; not an appropriate method of attaching tap clamps) (Refer to Category 4, K)
 - ii. No tap guards installed on conductor smaller than 1/0 Al and/or smaller than #2 Cu (Refer to Category 4, L)
 - iii. Installed on tap lines (jumpers) feeding more than 2 transformers based on what inspectors can see in the field (transformer banks count as 1 transformer). (Refer to Category 4, L)
 - iv. Used on any other type of equipment (recloser, capacitor, regulator, risers, etc.) other than a transformer. (Refer to Category 4, L)

Note: *Chance Clamp is a brand name; this is also known as a hot-line clamp or tap clamp, etc. Parallel Grove Connectors (PGs) are not included. PG's acceptable on armor rod is grandfathered from FRO standard 043052.*



K. Are tap clamps installed without tap guard or over armor rod?

- 1. (No) No Action
- 2. (Yes) Repair/Replace F Tag

L. Are tap clamps installed on main line-main line as a connector? Or on unapproved equipment

- 1. (No) No Action
- 2. (Yes) Repair/Replace E Tag

Example

INCORRECTLY INSTALLED CHANCE CLAMP	
 <p>Tap clamp on armor rod installed incorrectly.</p>	<p>At this Location: Incorrectly installed per note C above - chance clamp on armor rod.</p> <p> </p>
Perform Minor Work: No	
Write 3rd Party Notification: No	
Write EC Notification: Yes	
FDA: Connector / Incorrectly Installed / Replace	
Priority: F Tag, depending on exposure	

Are connections made with dissimilar metals installed incorrectly?

Proper installation is Aluminum over Copper.

Guidance: If installed incorrectly, write EC notification to replace connector.

ALUMINUM OVER COPPER	
	<p>At this Location Aluminum over Copper Installation.</p> <div style="display: flex; justify-content: space-around;"> </div>
	<p>Perform Minor Work: No</p>
	<p>Write 3rd Party Notification: No</p>
	<p>Write EC Notification: Yes</p> <p>FDA: Connector / Incorrectly Installed / Replace</p> <p>Priority: E Tag, depending on exposure.</p>

M. Is dissimilar metal connection(s) made with the CU over AL?

1. (No) No Action
2. (Yes) Repair/Replace E Tag





N. Is vibration damper installed over splice preventing free movement?

1. (No) No Action
2. (Yes) Repair/Replace E Tag

O. Splice under the tie wire or tied into the insulator?

1. (No) No Action
2. (Yes) Repair/Replace E Tag

Examples

SPLICES TIED INTO THE INSULATOR OR UNDER THE TIE WIRE		
		
<p>At this Location: Splice under the tie wire or tied into the insulator.</p>		
 		
<p>Perform Minor Work: No</p>		
<p>Write 3rd Party Notification: No</p>		
<p>Write EC Notification: Yes</p>		
<p>FDA = Conductor / Splice Tied In / Replace</p>		
<p>Priority = E Tag, depending on exposure</p>		

SPLICES TIED INTO THE INSULATOR OR UNDER THE TIE WIRE – AERIAL VIEW	
	<p>At this Location: Splice under the tie wire or tied into the insulator. Splice bent / damaged.</p> <p>Note: Example of insignificant contamination on insulator. Non-compelling condition.</p> <div style="text-align: center;">  </div>
	<p>Perform Minor Work: No</p>
	<p>Write 3rd Party Notification: No</p>
	<p>Write EC Notification: Yes</p> <p>FDA = Conductor / Splice Tied In / Replace</p> <p>Priority = E Tag, depending on exposure</p>

Part 2

Category 5 – Tie Wire Damaged but not broken yet.

Damaged / Corroded

General Guidance: Ensure tie wires are not damaged, broken, or corroded. Repair damaged service or secondary tie wire as minor work if possible. Ensure armor rod is installed and in good condition when applicable.

Visually inspect hand ties to identify wear prior to failure; utilize bucket truck, binoculars, or camera to get a closer look - especially on older installations.

If damage to conductor or tie wire, create EC notification.

Minor Work: Yes, on service or secondary only

IF not able to perform minor work, THEN create EC notification.

EC Notification: Yes, only if not able to perform minor work.

Select the Priority and Due Date based upon compelling abnormal condition.

Reference:

[052990 - Formed Insulator Ties for Distribution Line Conductors](#)

[028853 - Armor Rods and Ties for Aluminum Conductors](#)

[024079 - Armor Rods and Ties for Copper Conductors](#)

P. Is the tie wire loose or hand tie slipping?

1. (No) No action
2. (Yes) Imminent expectation of failure? Or tie wire off insulator?
 - a. (No) Repair/Replace E Tag
 - b. (Yes) Repair/Replace Level IA or IIX

Examples

LOOSE TIE WIRE	
At this Location: Loose tie wire	
Perform Minor Work: No	
Write 3rd Party Notification: No	
Write EC Notification: Yes	
FDA = Tie wire / Broken / Damaged / Repair / Replace	
Priority = E tag, depending on exposure.	

TIE WIRE SLIPPING AND COMING LOOSE	
	<p>At this Location: Tie wire is slipping.</p> <div style="display: flex; align-items: center; gap: 10px;">   </div>
	<p>Perform Minor Work: No</p>
	<p>Write 3rd Party Notification: No</p>
	<p>Write EC Notification: Yes</p>
	<p>FDA= Tie wire / Broken / Damaged / Repair / Replace</p> <p>Priority = X Tags, however extenuating circumstances may escalate to A Tag</p>



TIE WIRE LOOSE	
	<p>At this Location: Tie wire loose allowing insulators to spin, conductor not seated properly in the insulator saddle.</p> <div style="display: flex; align-items: center; gap: 10px;">   </div>
	<p>Perform Minor Work: No</p>
	<p>Write 3rd Party Notification: No</p>
	<p>Write EC Notification: Yes</p>
	<p>FDA= Tie wire / Broken / Damaged / Repair / Replace</p> <p>Priority = E Tag, depending on exposure.</p>

INSULATOR GROOVE	
	<p>At this Location: Up-strain on the conductor and the tie is not tight enough to secure the conductor in the insulator saddle.</p> <div style="display: flex; align-items: center; gap: 10px;">   </div>
	<p>Perform Minor Work: No</p>
	<p>Write 3rd Party Notification: No</p>
	<p>Write EC Notification: Yes</p> <p>FDA= Tie wire / Broken / Damaged / Repair / Replace</p> <p>Priority= E tag, depending on exposure.</p>

Q. Is the tie wire worn and/or corroded, and/or strands are broken?

1. (No) No action
2. (Yes) Is corrosion product staining insulator? (signs of excessive staining/discoloring of insulator) Or strands broken with imminent expectation of failure?
 - a. (No) Repair/Replace E Tag
 - b. (Yes) Repair/Replace Level IA or IIX

Examples

TIE WIRE CORRODED	
	<p>At this Location: Tie wire is corroded, strand is broken.</p> <div style="display: flex; align-items: center; gap: 10px;">   </div>
	<p>Perform Minor Work: No</p>
	<p>Write 3rd Party Notification: No</p>
	<p>Write EC Notification: Yes</p> <p>FDA=Tie Wire / Corroded / Replace</p> <p>Priority = X tag, depending on exposure.</p>

BROKEN / CORRODED TIE WIRE



At this Location: Corroded and broken tie wire, top tie, with one strand remaining, held in correct position by downward force.



Perform Minor Work: No

Write 3rd Party Notification: No

Write EC Notification: Yes

FDA = Tie wire / Broken / Damaged / Repair / Replace

Priority = E tag, depending on exposure.

BROKEN / CORRDED TIE WIRE



At this Location: Broken tie wire





Perform Minor Work: No

Write 3rd Party Notification: No

Write EC Notification: Yes

FDA = Tie wire / Broken / Damaged / Repair / Replace

Priority = X Tag, depending on exposure.

BROKEN / CORRODED TIE WIRE		
		
<p>At this Location: Broken tie wire</p>		
<p>   </p>		
<p>Perform Minor Work: No</p>		
<p>Write 3rd Party Notification: No</p>		
<p>Write EC Notification: Yes</p> <p>FDA = Tie wire / Broken / Damaged / Repair / Replace</p> <p>Priority = E tag, depending on exposure.</p>		

R. Is the tie wire improperly installed?

1. (No) No action
2. (Yes) Is it possible for the conductor to become unattached from the insulator?
 - (No) Repair/Replace E Tag
 - (Yes) Repair/Replace Level IA or IIX

Examples

IMPROPERLY INSTALLED TIE SLIPPED BELOW INSULATOR	
	<p>At this Location: Improperly installed tie slipped below the insulator, now hanging from the spool pin.</p> <div style="display: flex; justify-content: space-around;">   </div>
	<p>Perform Minor Work: No</p>
	<p>Write 3rd Party Notification: No</p>
	<p>Write EC Notification: Yes</p> <p>FDA= Tie wire / Broken / Damaged / Repair / Replace</p> <p>Priority = E Tag, depending on exposure.</p>

S. Is the insulator steel pin bent? (Especially on angle poles)

1. (No) No action
2. (Yes) Is it possible for conductor to conductor to become unattached from the insulator?
 - a. (No) Repair/Replace E Tag
 - b. (Yes) Repair/Replace Level IA or IIX

Examples

ANGLE POLE WITH TIE WIRE, BENT STEEL PIN	
	<p>At this Location: Angle pole with post top insulator, where the inside angle insulator conductor is only being supported by tie wire (non-clamped). Post top insulator steel pin is bent.</p> <div style="display: flex; align-items: center; gap: 10px;"> </div>
<p>Perform Minor Work: No</p>	
<p>Write 3rd Party Notification: No</p>	
<p>Write EC Notification: Yes</p>	
<p>FDA= Tie wire / Broken / Damaged / Repair / Replace</p>	
<p>Priority = X Tag, depending on exposure.</p>	

**CONDUCTOR TIED TO THE SIDE OF SKIRT,
NOT IN GROOVE**



At this Location: Insulator spun, and conductor tied on the skirt, non-angle pole.



Perform Minor Work: No

Write 3rd Party Notification: No

Write EC Notification: Yes

FDA = Tie Wire / Broken / Damaged / Replace

Priority = B Tag, depending on exposure



Category 6 – Floater (tie wire broken or insulator is broken from framing)

T. Is the conductor floating? Or sitting on the crossarm?

1. (No) No action
2. (Yes) Repair/Replace Level IA or IIX

Examples

FLOATER	
	<p>At this Location: Floater, conductor is not contacting the arm. Rotten crossarm.</p> <p> </p>
	<p>Perform Minor Work: No</p>
	<p>Write 3rd Party Notification: No</p>
	<p>Write EC Notification: Yes</p> <p>FDA=Crossarm / Decayed/Rotten/ Replace</p> <p>FDA= Conductor / Floater / Repair</p>
	<p>Priority= X Tags, however extenuating circumstances may escalate to A Tag.</p>

FLOATER	
	
<p>At this Location: Insulator lying on its side. Primary on the arm.</p>	
<p>   </p>	
<p>Perform Minor Work: No</p>	
<p>Write 3rd Party Notification: No</p>	
<p>Write EC Notification: Yes</p> <p>FDA= Crossarm / Decayed/Rotten / Replace</p> <p>FDA= Conductor / Floater / Repair</p> <p>Priority= A Tag, depending on exposure.</p>	

BROKEN WOOD PIN ON SECONDARY/FLOATER

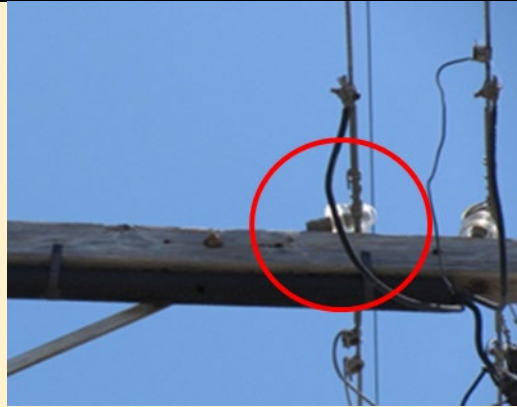

At this Location: Broken secondary wood pin. Conductor lying on the arm, tangent pole. (Excluding urban wildfire areas, use risk priority matrix). Wood pin arm at end of life replace arm with composite arm.



Perform Minor Work: Yes, if safe to do so

Write 3rd Party Notification: No

Write EC Notification: Yes, if minor work not possible

FDA= Crossarm / Decayed/Rotten / Replace

FDA= Conductor / Floater / Replace

Priority= X Tag, depending on exposure.

BROKEN WOOD PIN ON PRIMARY (FLOATER)

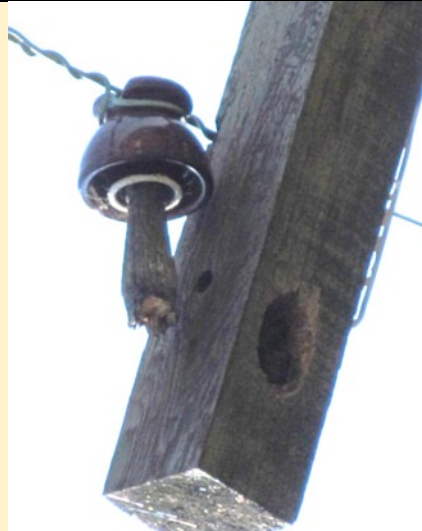

At this Location: Broken wood pin. Conductor on arm. Replace all insulators and the crossarm with a composite arm.



Perform Minor Work: No

Write 3rd Party Notification: No

Write EC Notification: Yes

FDA= Crossarm / Decayed/Rotten / Replace

FDA= Conductor / Floater / Repair



Priority= A Tag, follow Emergency Process, (Conductor contacting crossarm)

BROKEN TIE WIRE	
	<p>At this Location: Broken tie wire, which caused a floating conductor condition (sitting on the cross-arm) Insufficient clearance.</p>
	
	<p>Perform Minor Work: No</p>
	<p>Write 3rd Party Notification: No</p>
	<p>Write EC Notification: Yes</p> <p>FDA= Conductor / Floater / Repair</p> <p>Priority= A Tag, Follow emergency procedure</p>

U. Is the conductor out of the insulator groove?

1. (No) No action
2. (Yes) Is it possible for the conductor to fall off the insulator?
 - a. (No) Repair/Replace E Tag
 - b. (Yes) Repair/Replace Level IA or IIX

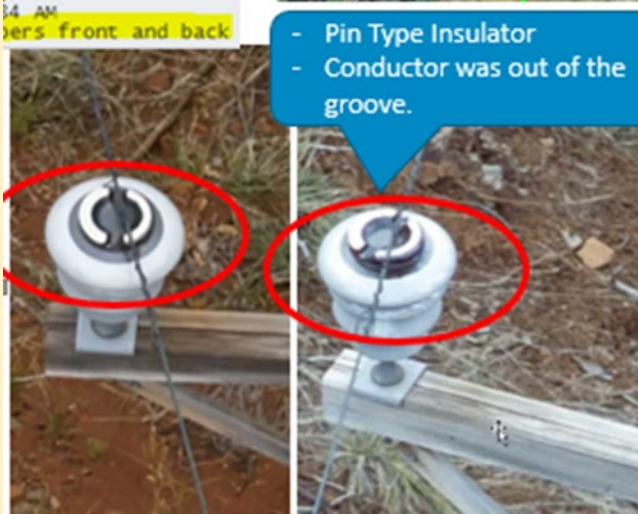
Examples

CONDUCTOR TIED TO SIDE OF SKIRT, NOT IN GROOVE	TIE WIRE BROKEN / LOOSE / NOT IN GROOVE
	
<p>At this Location: Insulator spun, and conductor tied on the skirt.</p> 	<p>At this Location: Tie Wire Broken / Loose / Not in Groove</p> 
<p>Perform Minor Work: No</p>	<p>Perform Minor Work: No</p>
<p>Write 3rd Party Notification: No</p>	<p>Write 3rd Party Notification: No</p>
<p>Write EC Notification: Yes</p> <p>FDA = Tie Wire / Broken / Damaged / Replace</p> <p>Priority = X tag, depending on exposure.</p>	<p>Write EC Notification: Yes</p> <p>FDA = Tie Wire / Improperly Installed / Repair</p> <p>Priority = X tag, depending on exposure.</p>

QUESTIONALBE TIE WIRE



At this Location: Not obvious if it's still attached. Insulator has spun.



Perform Minor Work: No

Write 3rd Party Notification: No

Write EC Notification: Yes

FDA = Tie wire / Broken / Damaged / Repair / Replace

Priority = X Tag, depending on exposure.

Category 7 – Conductor Clearance



JUMPER TENSION	
	
At this Location: Jumper Tension, pulling over cutout.	
	
Perform Minor Work: No	
Write 3rd Party Notification: No	
Write EC Notification: Yes	
FDA= Jumper / Clearance impaired / Adjust	
Priority= E Tag, depending upon exposure	



V. Is there insufficient clearance between conductor/connector and cross-arm.

1. (No) No action
2. (Yes) Repair/Replace E Tag

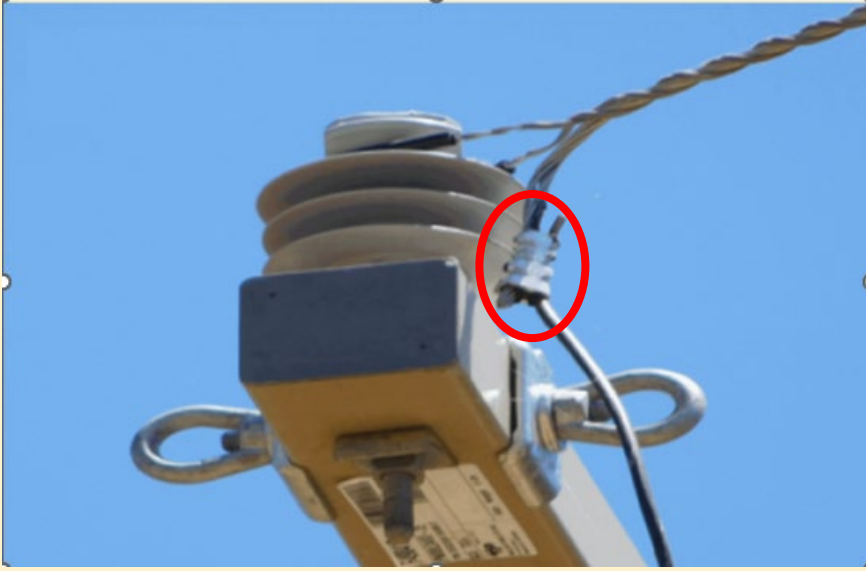
Example

INSUFFICIENT CLEARANCE – AERIAL VIEW	
	<p>At this Location: Over the top jumper laying on cross-arm.</p> <div style="display: flex; align-items: center; gap: 10px;"> 🚶 🚁 </div>
	<p>Perform Minor Work: No</p>
	<p>Write 3rd Party Notification: No</p>
	<p>Write EC Notification: Yes</p>
	<p>FDA: Jumper / Clearance / Impaired / Adjust</p> <p>Priority: A Tag, Follow the emergency process</p>

INSUFFICIENT CLEARANCE	
	At this Location: Insufficient clearance between connector and cross-arm 
	Perform Minor Work: No
	Write 3rd Party Notification: No
	Write EC Notification: Yes FDA: Conductor / Clearance / Impaired / Adjust Priority: E Tag, depending on exposure

JUMPER CLEARANCE	
	
At this Location: Jumper Clearance	
 	
Perform Minor Work: No	
Write 3rd Party Notification: No	
Write EC Notification: Yes	
FDA= Jumper / Clearance impaired / Adjust	
PRIORITY= E TAG, DEPENDING UPON EXPOSURE	

W. Is the conductor sagging and does not meet the required clearance distance?

1. (No) No action
2. (Yes) Is there a public safety hazard?
 - a. (No) Repair/Replace E Tag
 - b. (Yes) Repair/Replace Level IA or IIX

Example

UNSUPPORTED TRANSMISSION LINE WITH DIMINISHED CLEARANCE	
<p>At this Location: Unsupported transmission line with diminished clearance to the distribution level seen from the ground or aerial.</p>	
<p> </p>	
<p>Perform Minor Work: No</p>	
<p>Write 3rd Party Notification: No</p>	
<p>Write EC Notification: Yes</p>	
<p>FDA = OH Facility / Transmission Issue / Create LC</p>	
<p>Priority = E Tag, depending on exposure</p>	

X. Uneven Sag? (Secondary)



1. (No) No action
2. (Yes) Is the conductor low or in danger of making contact to adjacent phase or object?
 - a. (No) Repair/Replace E Tag
 - b. (Yes) Repair/Replace Level IA or IIX

Examples

SAGGING CONDUCTOR	
	<p>At this Location: Sagging Conductor</p> <div style="display: flex; gap: 10px;"> </div>
	<p>Perform Minor Work: No</p>
	<p>Write 3rd Party Notification: No</p>
	<p>Write EC Notification: Yes</p>
	<p>FDA= Conductor / Sag / Clearance / Adjust</p> <p>PRIORITY= E Tag, depending on exposure.</p>

- A. Open wire secondary conductor with rack construction has missing spreader brackets for spans > 135'.

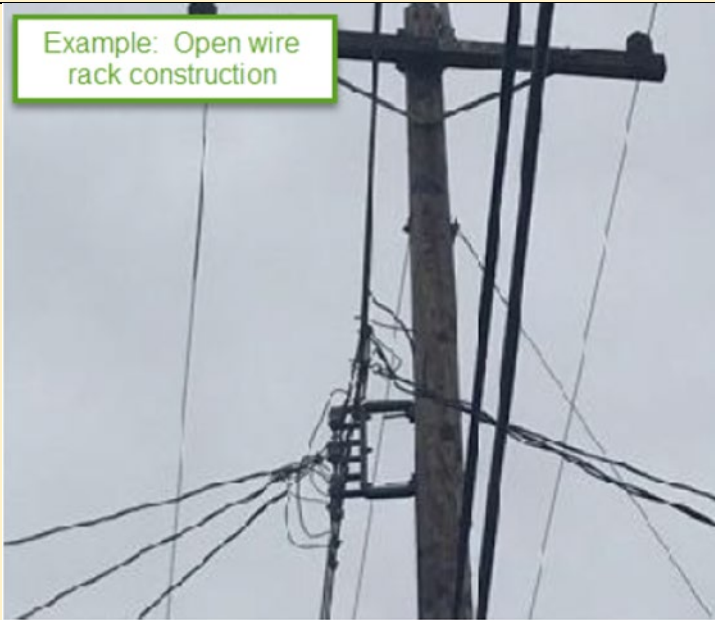
General Guidance: If observed, create EC Notification to have spreader brackets installed where bucket truck accessible; use line of sight and if available, foreman-cane or rangefinder.

OPEN WIRE RACK CONSTRUCTION	
	<p>At this Location: Span length >135' missing spreader bracket for open wire extended rack construction.</p> <p> </p>
	<p>Perform Minor Work: No</p>
	<p>Write 3rd Party Notification: No</p>
	<p>Write EC Notification: Yes</p> <p>FDA= Conductor / Sag / Clearance / Install Spreader Bracket</p> <p>Priority = E Tag, 3-12 months depending on exposure</p>



Service Conductor

Category 1 – Exposed hot leg on the service

Look for broken service neutrals go to Flow A, if there are signs that the neutral is in poor condition i.e., damaged, burnt, loose, corroded, showing signs of wearing and about to fail, go to process Flow B. Conductor separation issues.

- **General Guidance:** Use binoculars. If observed, Create EC to repair or replace conductor

A. Is there a broken or open service neutral?

1. (No) No action
2. (Yes) Repair/Replace Level IA or Level IIX

BROKEN OR OPEN SERVICE NEUTRAL

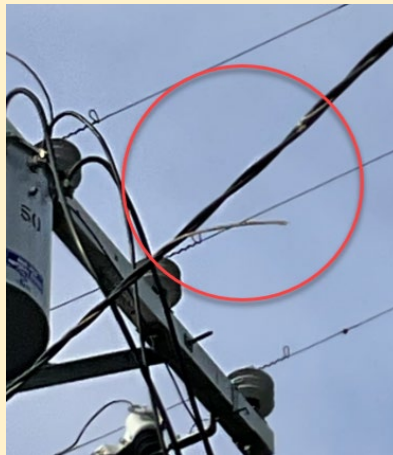

At this Location: Broken / Open Service neutral



Perform Minor Work: Yes, if safe to do so. If you replace the service conductor, this is capital Minor Work. Fill out EC Notification to account for this minor work.

Write 3rd Party Notification: No

Write EC Notification: Yes, if minor work is not possible, or to document completed capital minor work.

FDA = Conductor / Broken / Damaged / Repair or Replace

Priority = A Tag, Emergency due to broken service neutral, ~~exposed hot leg~~, follow emergency process

EXAMPLE OF DAMAGE BEFORE INSTALLATION	
	<p>At this Location: Service insulation damaged on the surface.</p> <div style="display: flex; align-items: center; gap: 10px;">   </div>
	<p>Perform Minor Work: Yes</p>
	<p>Write 3rd Party Notification: No</p>
	<p>Write EC Notification: Yes</p> <p>FDA= Conductor / Broken / Damaged / Repair</p> <p>Priority = E Tag, depending on exposure</p>



Is the service conductor cracked, exposing the hot leg?

- **General Guidance:** Use binoculars. Evaluate service drops looking for cracked or damaged insulation exposing hot legs and bundled together cross phase. If insulation is cracked or damaged to the point where hot leg is exposed, this is a minimum X Tag and maybe an Emergency/Standby condition.

B. Deteriorated service wire exposing one of the hot legs and bundled together with a potential for cross phase?

1. (No) No action
2. (Yes) Repair/Replace Level IA or IIX

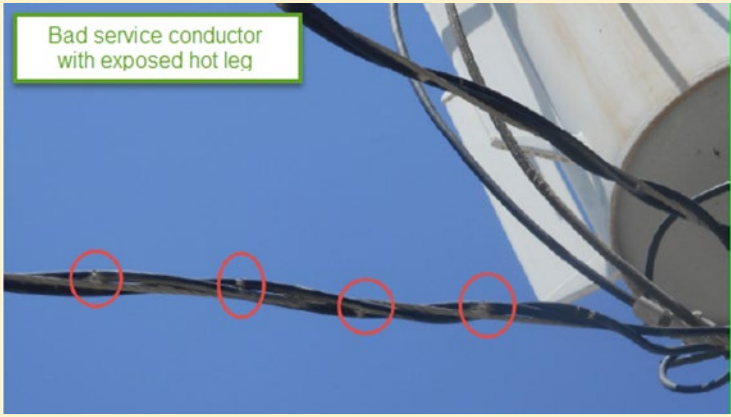
Examples

BAD SERVICE CONDUCTOR WITH EXPOSED HOT LEG	
	<p>At this Location: Bad service conductor with exposed hot leg, bundled with a potential to cross phase.</p> <p> </p>
Perform Minor Work: No	
Write 3rd Party Notification: No	
Write EC Notification: Yes	
<p>FDA: FDA = Conductor / Broken / Damaged / Replace</p> <p>Priority: X Tag or A Tag, depending on exposure.</p>	

OVERHEAD SERVICE STRAIN OR ABRASION	OVERHEAD SERVICE STRAIN OR ABRASION
	
<p>At this Location: Service strain abrasion, with possible burning at some sections. Damaged insulation.</p> 	<p>At this Location: Service strain abrasion, no slack remaining.</p> 
<p>Perform Minor Work: Yes, if safe to do so. If you replace the service conductor, this is capital Minor Work.</p> <p>Fill out EC Form to account for this minor work; charge time to your division standing order.</p>	<p>Perform Minor Work: Yes, if safe to do so. If you replace the service conductor this is capital Minor Work.</p> <p>Fill out EC Form to account for this minor work; charge time to your division standing order.</p>
<p>Write 3rd Party Notification: No</p>	<p>Write 3rd Party Notification: No</p>
<p>Write EC Notification: Yes, if minor work not possible, or to document completed capital minor work</p> <p>FDA = Conductor / Broken / Damaged Repair or Replace</p> <p>Priority = E Tag, depending on exposure, in comments add note about strain abrasion burnt conductor</p> <p>If abrasion has caused an exposed hot leg, assign Priority "A", emergency, and stand-by.</p>	<p>Write EC Notification: Yes, if minor work not possible, or to document completed capital minor work</p> <p>FDA = Conductor / Broken / Damaged Repair or Replace</p> <p>Priority = E Tag, depending on exposure, in comments add note about strain abrasion burnt conductor</p> <p>If abrasion has caused an exposed hot leg, assign Priority "A", emergency, and stand-by.</p>



Visually check service conductors going into riser, especially at the bend radius and cable grip, observe potential fraying of the conductor insulation at the entry point to the molding or conduit for exposed hot leg, etc.

General Guidance: Use binoculars. If observed, Create EC to repair or replace conductor.

C. Is the hot leg frayed at the entry point of molding of the riser?

1. (No) No action
2. (Yes) Repair/Replace Level IA or IIX

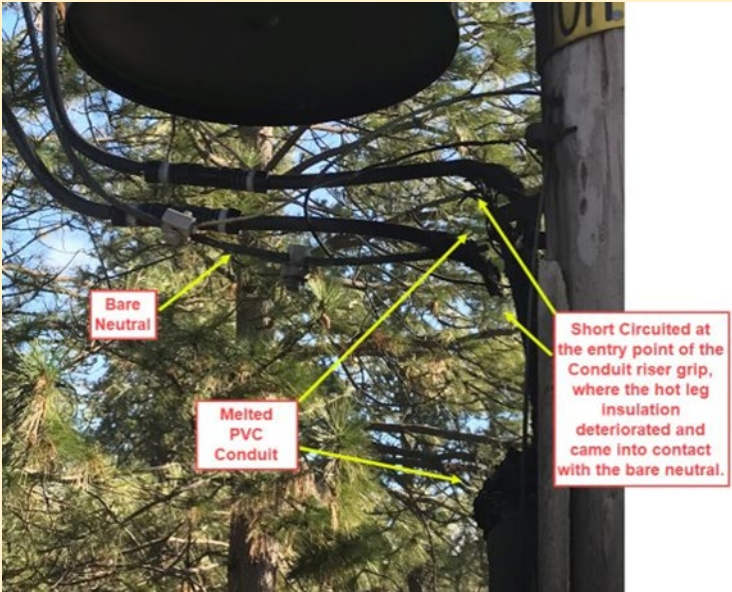

Example

SECONDARY SERVICE RISER DROPS	
	
<p>At this Location: hot leg insulation frayed at the point of entry point of the molding exposing the conductor into contact with the neutral</p>	
<div style="display: flex; align-items: center; gap: 10px;"> </div>	
<p>Perform Minor Work: No</p>	
<p>Write 3rd Party Notification: No</p>	
<p>Write EC Notification: Yes</p>	
<p>FDA=Conductor / Broken / Damaged / Replace</p>	
<p>Priority= A Tag or X tag depending on exposure.</p>	

D. Is service conductor insulation cracked, abrasions, holes?

1. (No) No action
2. (Yes) Is Hot Leg Exposed?
 - a. (No) Repair/Replace E Tag
 - b. (Yes) Is there localized corrosion on lashing or neutral conductor interfaces?
 - i. (Yes) Repair/Replace Level I: A
 - ii. (No) Is there sufficient airgap between conductors?
 1. (Yes) Repair/Replace E Tag
 2. (No) Repair/Replace Level II:X



Examples

DAMAGED / CRACKED GREY SERVICE	
	<p>At this Location: Cracked grey service / Aerial cable. Older grey services tend to crack and will appear to have rings around the insulation. Loose lashing, visually cracked, discoloration/corrosion, Degradation. No evidence of arching.</p> <p> </p>
	<p>Perform Minor Work: Yes, if safe to do so. If you replace the service conductor, this is capital Minor Work.</p> <p>Fill out EC Notification to account for this minor work.</p>
	<p>Write 3rd Party Notification: No</p>
	<p>Write EC Notification: Yes</p> <p>FDA=Conductor / Broken / Replace OR</p> <p>FDA=Conductor / Damaged / Replace OR</p> <p>FDA=Conductor / Burnt / Replace</p> <p>Priority = E Tag, depending on exposure <u>Consider A-Tag</u> if signs of tracking between phases presents.</p>

E. Is there exposed service connector?

1. (No) No action
2. (Yes) Can Minor work be performed?
 - a. (No) Repair/Replace E Tag
 - b. (Yes) Perform Minor Work

Examples

EXPOSED SERVICE CONNECTOR	
	<p>At this Location: Exposed Conductors, with an acceptable air gap between conductors</p> <div style="display: flex; align-items: center; gap: 5px;">   </div>
	<p>Perform Minor Work: Yes, if safe to do so</p>
	<p>Write 3rd Party Notification: No</p>
	<p>Write EC Notification: Yes, if minor work cannot be performed.</p> <p>FDA= Conductor / Broken / Damaged / Repair</p> <p>Priority = E Tag, depending on exposure</p>

EXAMPLE OF MINOR WORK	
	<p>At this Location: Hot leg is exposed next insulink</p>
	<p>Perform Minor Work: Yes</p>
	<p>Write 3rd Party Notification: No</p>
	<p>Write EC Notification: Yes</p>
	<p>FDA= Conductor / Broken / Damaged / Repair</p> <p>Priority = E Tag, depending on exposure</p> <p>Note: Carefully evaluate for potential of conductors to get together</p>

EXAMPLE OF MINOR WORK



At this Location: Hot leg exposed next to insulink

Perform Minor Work: Yes

Write 3rd Party Notification: No

Write EC Notification: Yes

FDA= Conductor / Broken / Damaged / Repair

Priority = E Tag, depending on exposure



Category 2 – Broken Service Bob



F. Is service insulator unattached between the conductor and the insulator?

1. (No) No action
2. (Yes) Can Minor work be performed?
 - a. (No) Repair/Replace E Tag
 - b. (Yes) Perform Minor Work

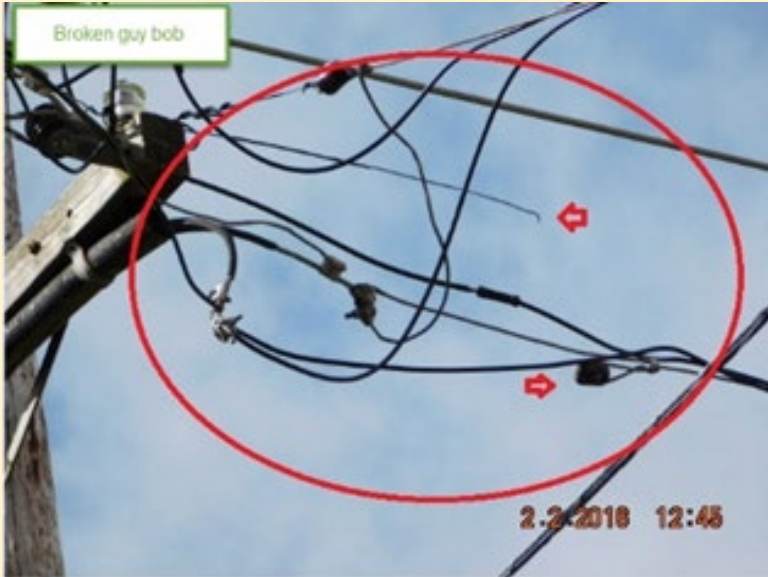
Examples

HARDWARE BROKEN	
	At this Location: The #6 solid copper is broken causing strain on the conductor. Unsecured service.
	Perform Minor Work: Yes, if safe to do so
	Write 3rd Party Notification: No
	Write EC Notification: Yes, if minor work cannot be performed. FDA= Hardware / Framing / Broken / Damaged / Repair Priority = E Tag, consider X tag or A tag, depending on length of service and exposure.

BROKEN SERVICE BOB	
	<p>At this Location: Broken service Insulator which has become unattached between the copper wire and the insulator.</p> <p> </p> <p>Perform Minor Work: No</p> <p>Write 3rd Party Notification: No</p> <p>Write EC Notification: Yes</p> <p>FDA= Hardware/Framing / Broken / Damaged / Repair</p> <p>Priority= E Tag, consider X tag or A tag, depending on length of service and exposure.</p>

PREFORM NOT ATTACHEHD TO INSULATOR	
	<p>At this Location: Preform not attached to the insulator, rural area, low exposure with no vehicular access.</p> <p> </p> <p>Perform Minor Work: Yes, if safe to do so.</p> <p>Write 3rd Party Notification: No</p> <p>Write EC Notification: Yes</p> <p>FDA=Tie Wire / Loose / Replace</p> <p>Priority = E Tag, possible B Tag, depending on exposure</p>



Category 3 – Conductor Clearance

General Guidance: Refer to the Conductor [Clearance Job Aid](#) and below.

G. Is there insufficient clearance between conductors/connector?

- a. (No) No Action
- b. (Yes) Repair/Replace E Tag

H. Is the conductor sagging and does not meet the required clearance distance?

- 1. (No) No action
- 2. (Yes) Is there public safety hazard?
 - a. (No) Repair/Replace E Tag
 - b. (Yes) Repair/Replace Level IA or IIX

I. Is the service conductor sagging and does not meet the required clearance distance?

- 3. (No) No action
- 4. (Yes) Does conductor cross public road?
 - a. (Yes) Is clearance less than 14 feet?
 - i. (Yes) Repair/Replace Level 1: A
 - ii. (No) Is there a public safety hazard?
 - 1. (Yes) Repair/Replace Level IA or Level IIX
 - 2. (No) Repair/Replace E Tag
 - b. (No) Is there a public safety hazard?
 - i. (Yes) Repair/Replace Level IA or Level IIX
 - ii. (No) Repair/Replace E Tag



Clearance Evaluation Job Aid

This section is developed based on:

- [TD-2305M-JA12 – Overhead Clearance Evaluation](#)
- [022158 – Clearance Tables CPUC GO95](#)
- [022187-Vertical Separation of Overhead Transmission, Distribution, and Telephone Circuits](#)

to assist Electric Distribution Compliance Inspectors, PG&E Employees, and Contractors in assessing and evaluating conductor clearance issues they visually identify in the field. While this section does not show all examples of allowed clearances, please review the references above for GO95 conductor clearance tables or contact your lead / supervisor for guidance.

This section addresses common conductor clearances such as:

- Wire/Ground minimum allowed clearance (ft)
- Service Drop minimum allowed clearance (ft)
 - Residential
 - Commercial
- Wire/Wire minimum allowed clearance (ft)
 - On same pole
 - On crossing poles
- Wire/Building minimum allowed clearance (ft)

Ground Clearances

Guidance Document References:

TD-2305M – EDPM 2011 Manual

**Engineering Document 022158 – Clearance Tables CPUC
General Order 95**

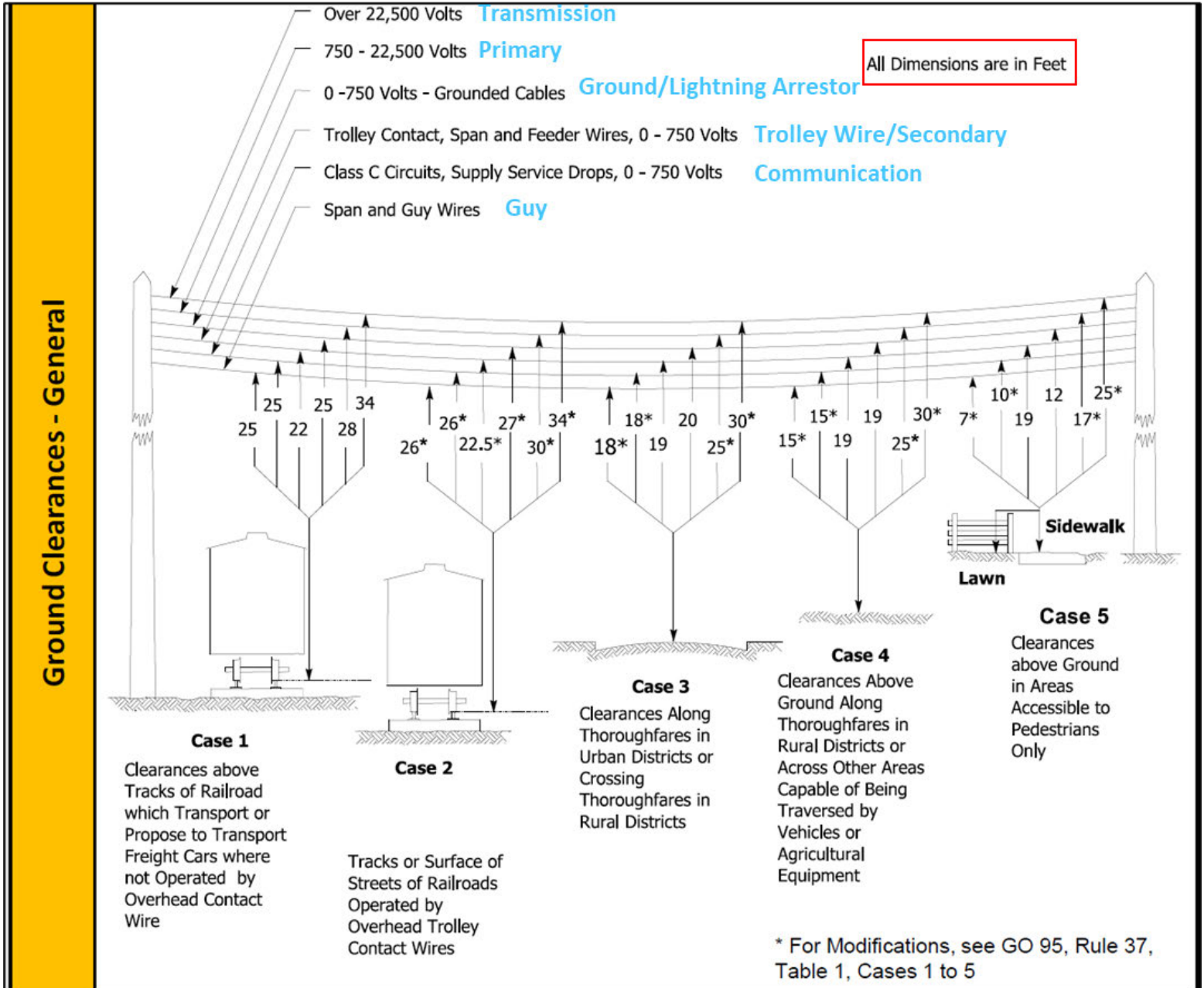



Case 1: Non-Contact Railroad

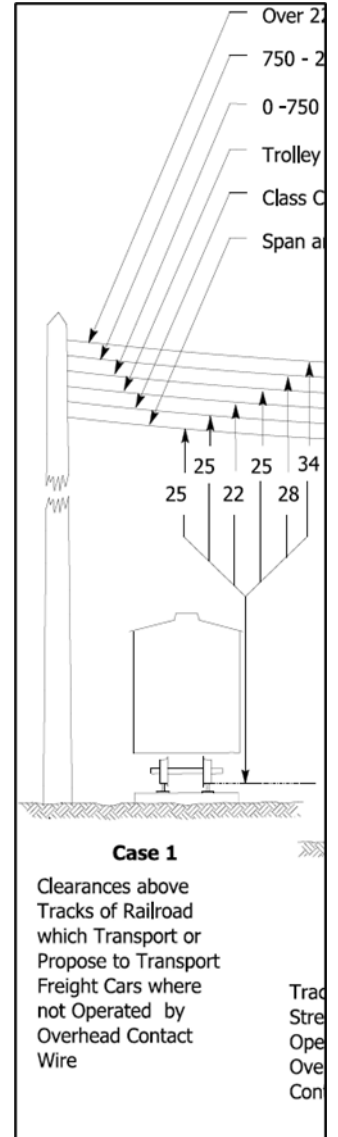



Case 2: Contact Railroad

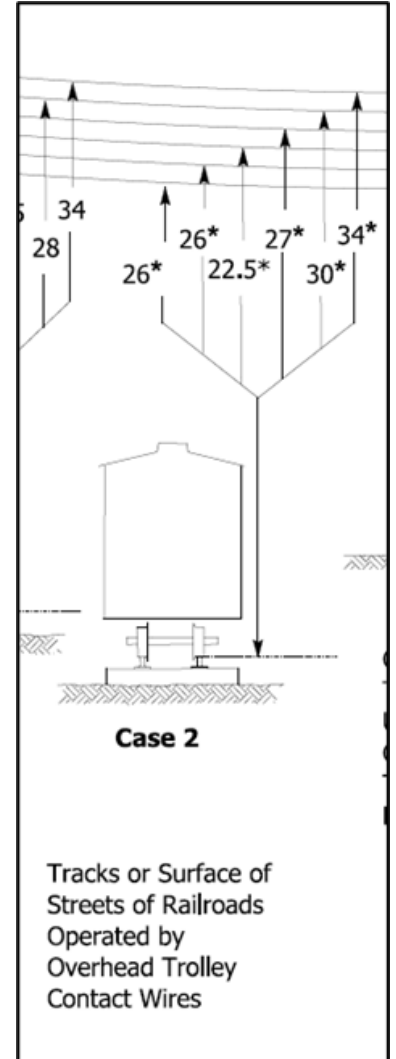
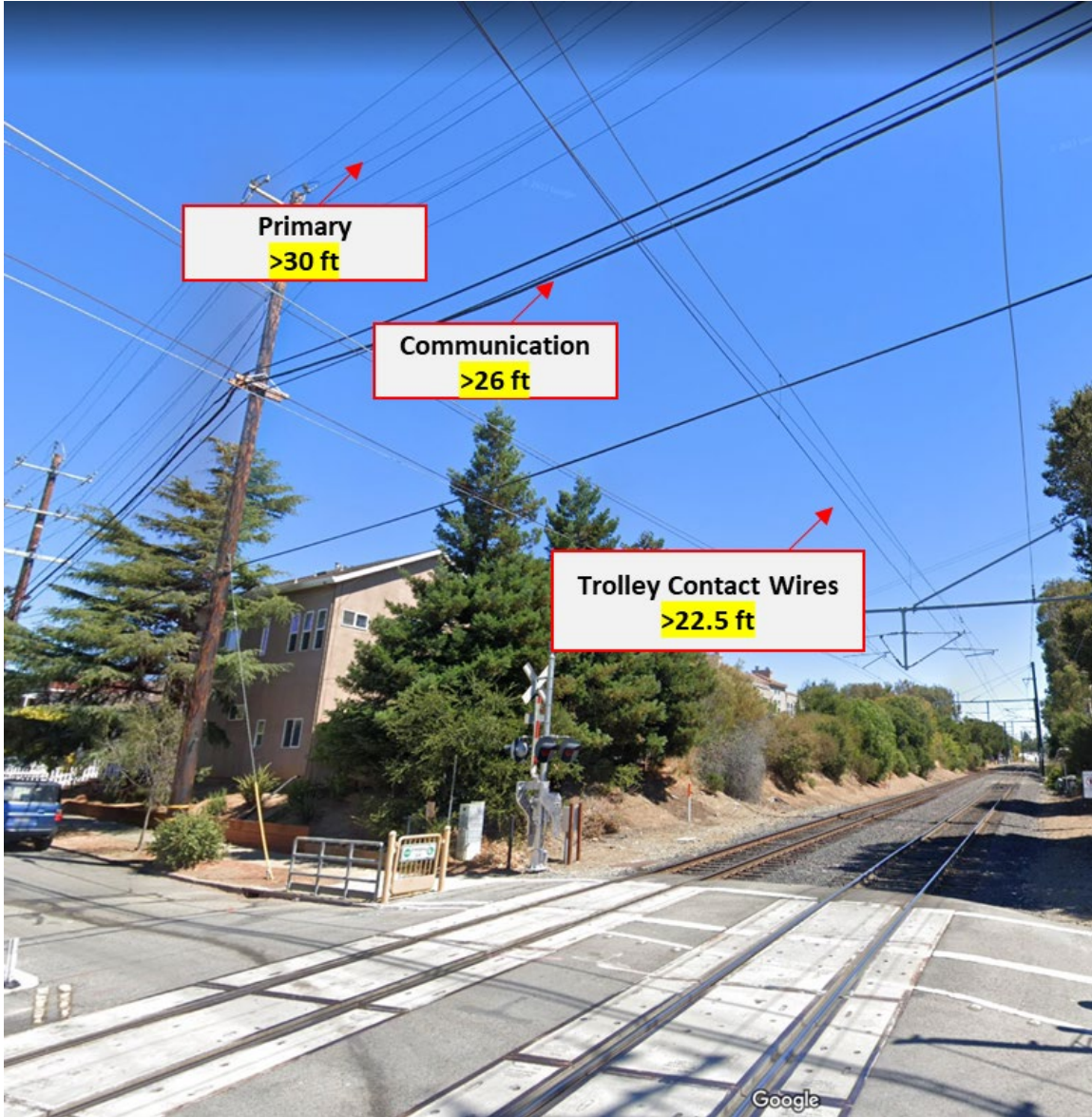



Case 3: Along or Crossing an Urban Road

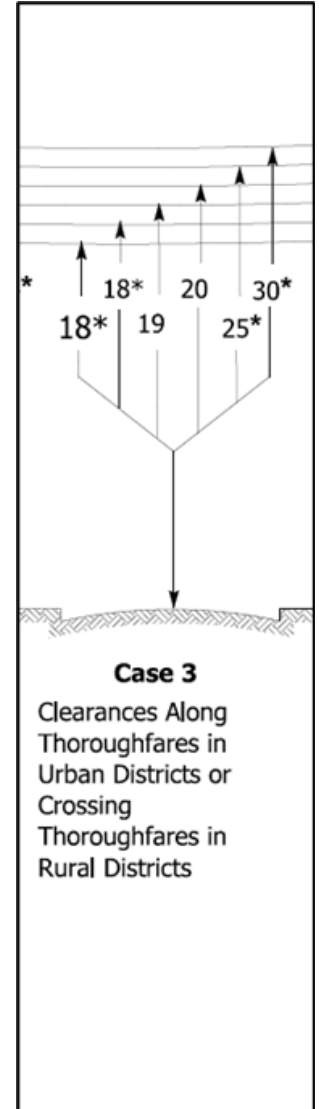



Job Aid: Overhead Assessment

Case 4: Along or Crossing a Rural Road

NOTE: Due to the fisheye lens and the online street view, the poles appear to be leaning but are not.

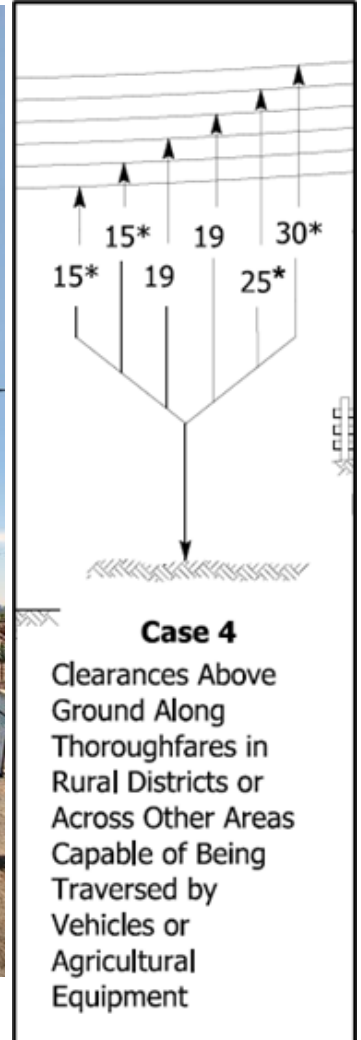
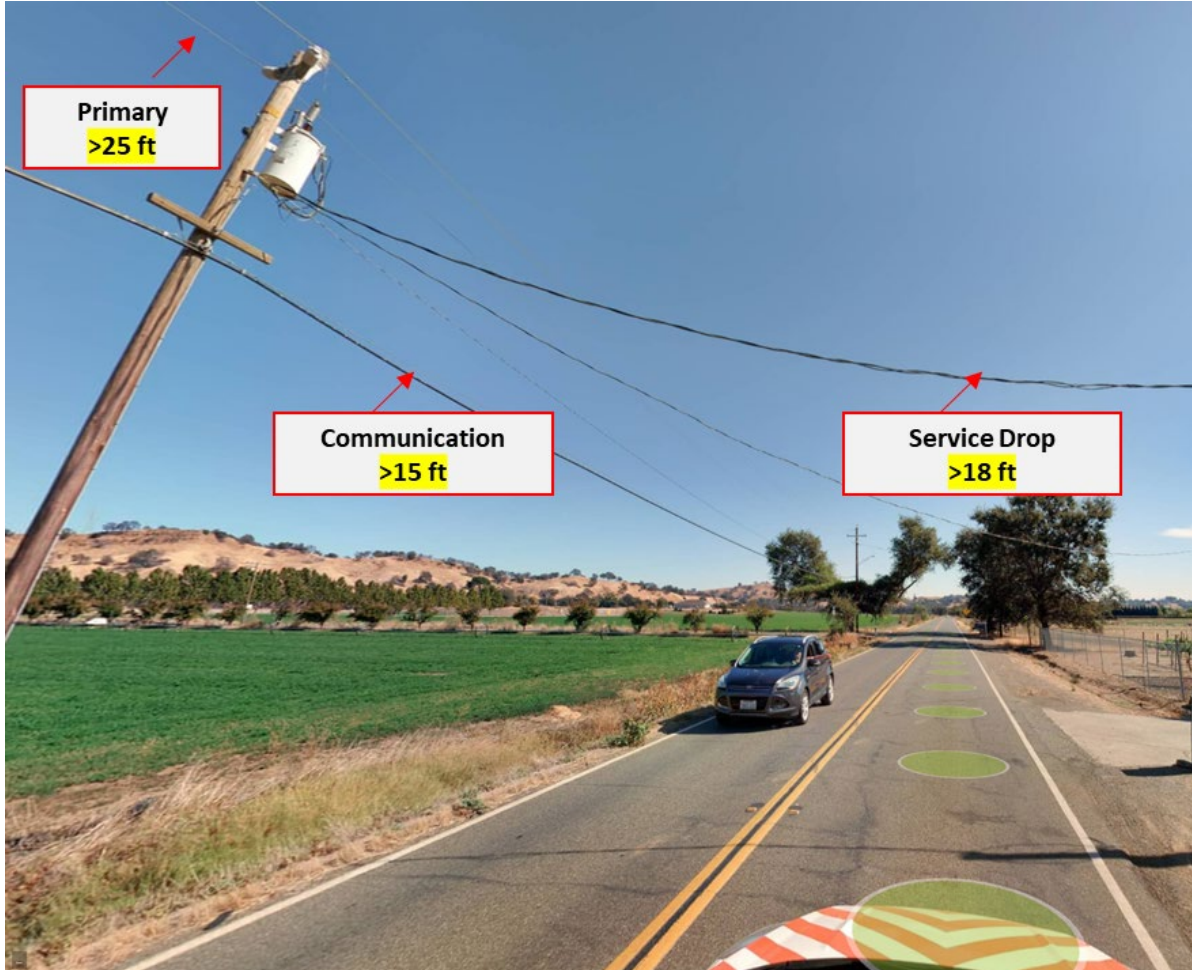



Case 5: Pedestrian Access - Sidewalk

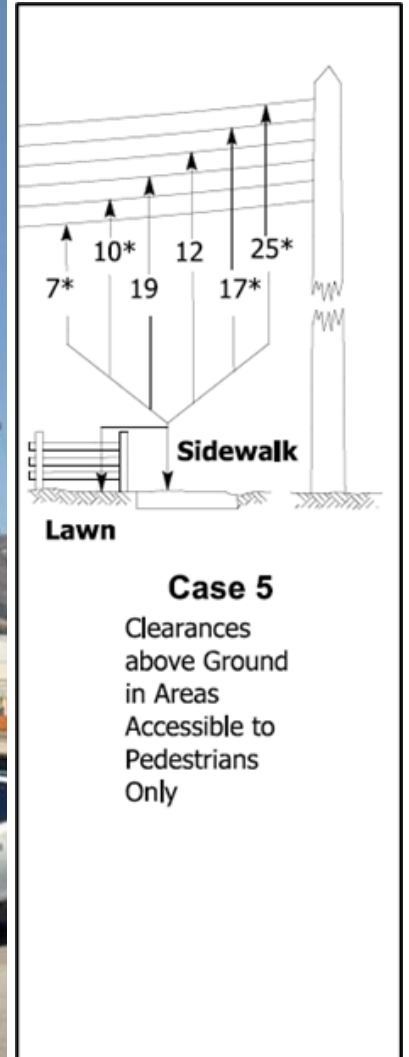

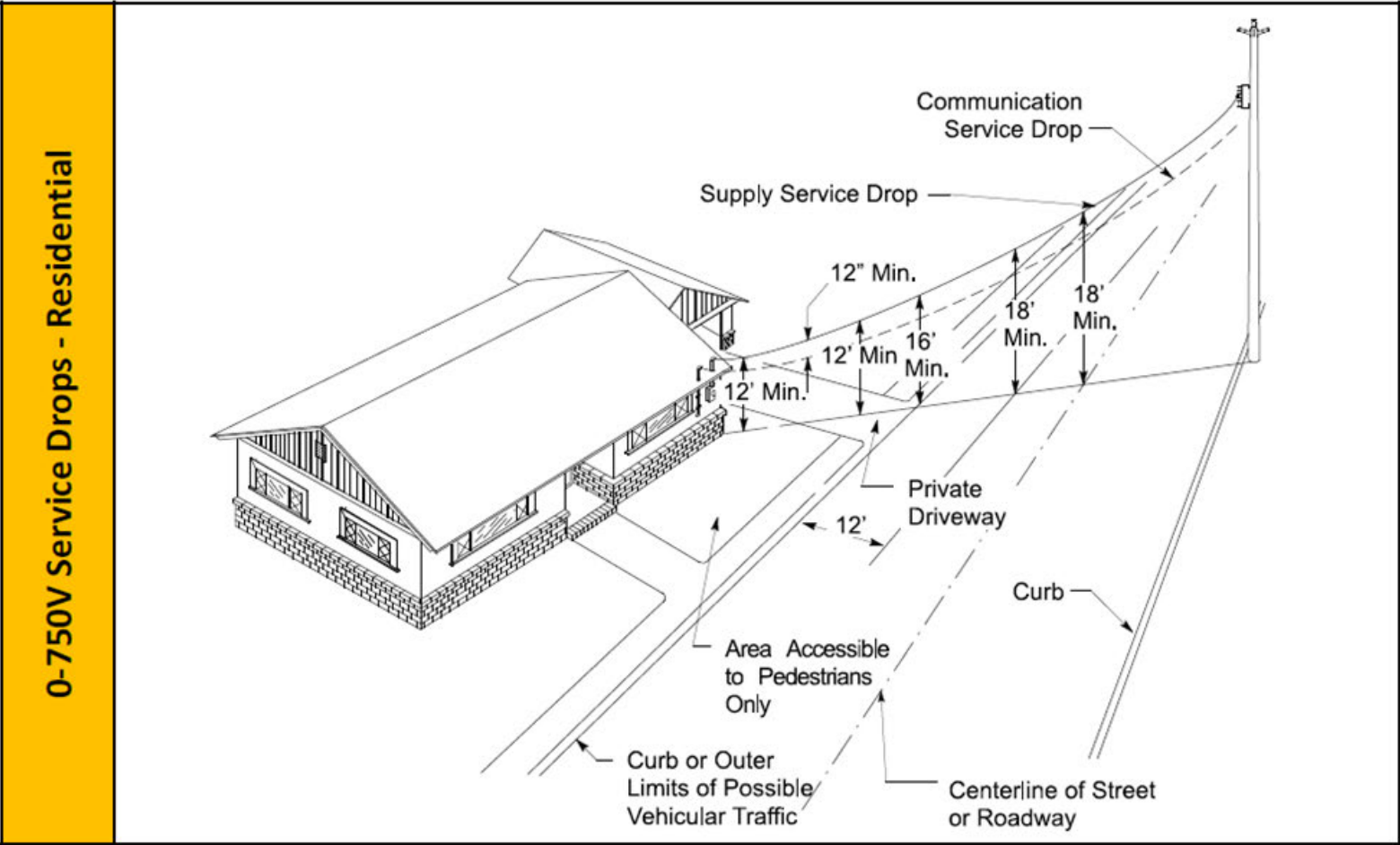



Job Aid: Overhead Assessment

TD-2305M-JA02

Publication: Jan 4, 2024, Effective: Feb. 1, 2024

Rev: 12

Service Drop – Residential

NOTE: Due to the fisheye lens and the online street view, the poles appear to be leaning but are not.



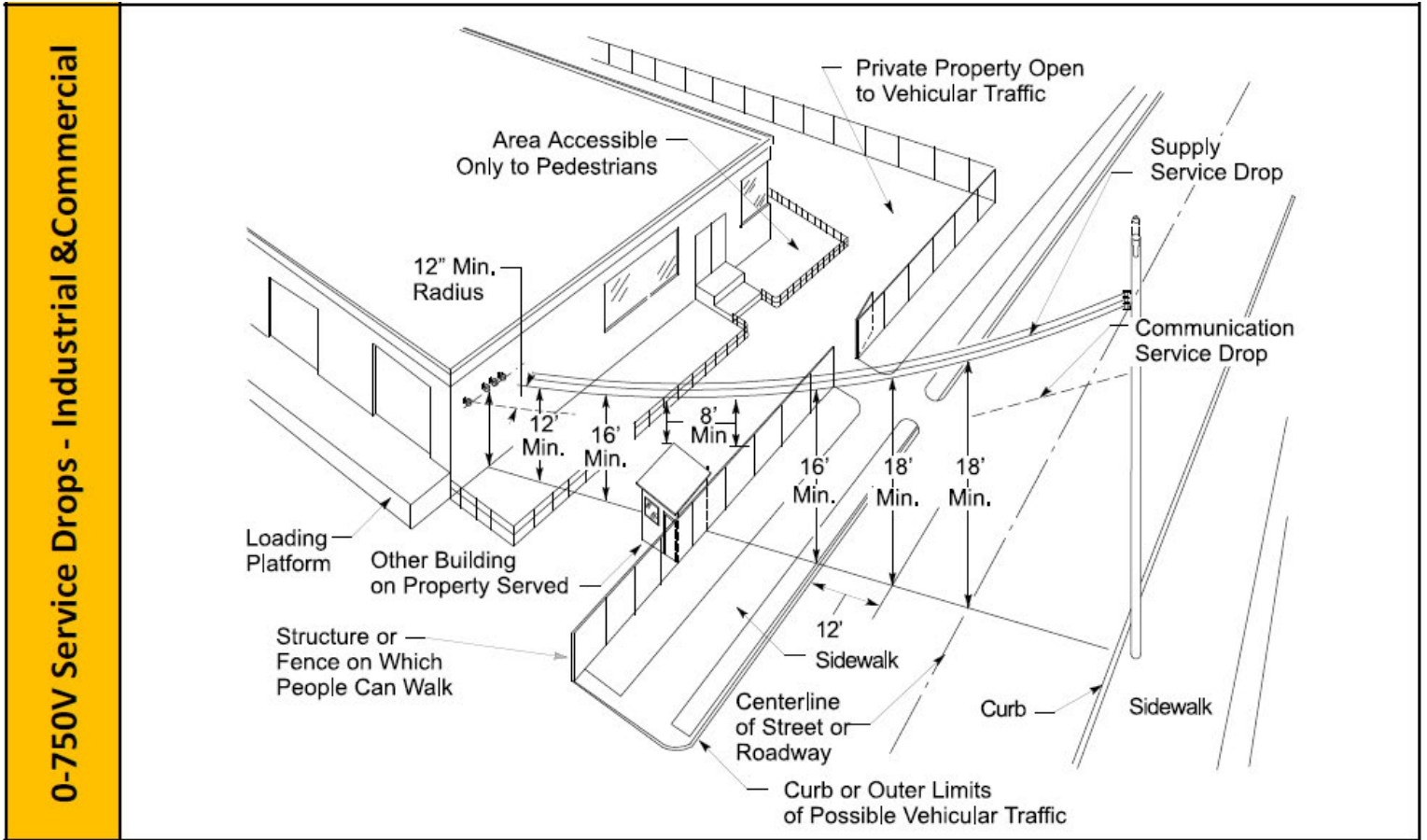



Service Drop – Commercial





Conductor to Conductor Clearance – On Same Pole

Conductor to Conductor Clearances – On Same Pole

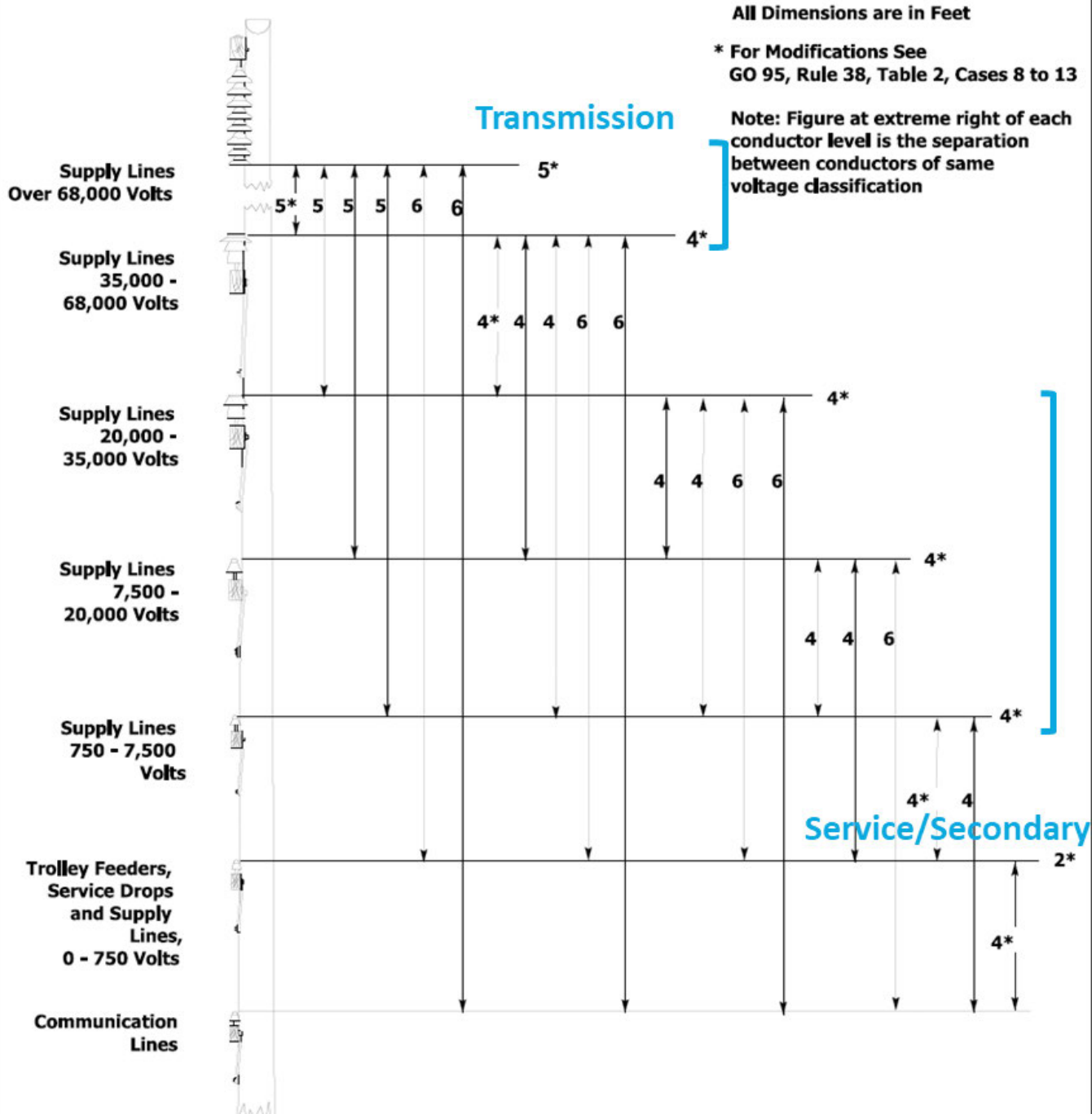



Same Pole Conductor Clearances

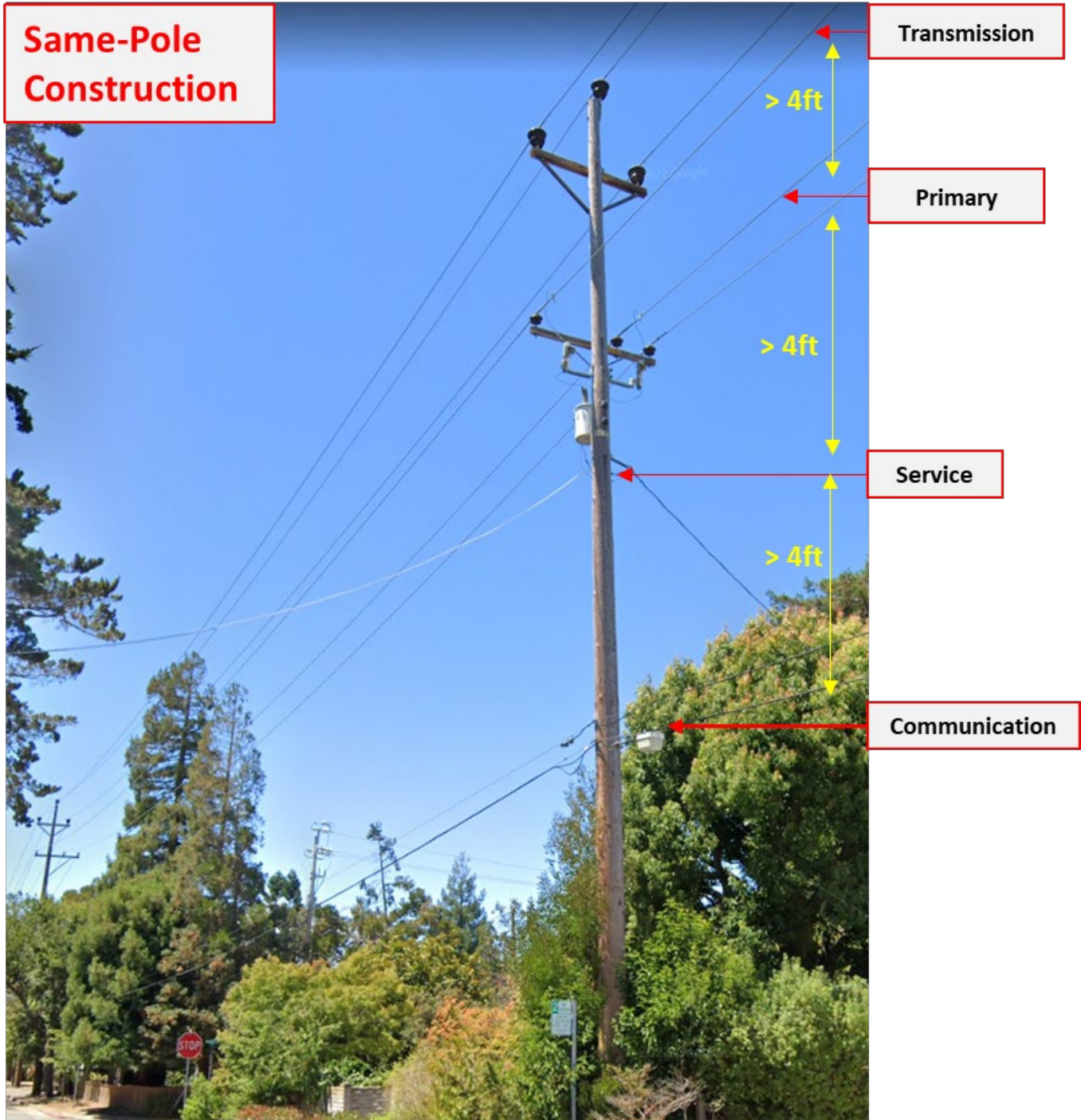

Conductor to Conductor Clearance on Crossing Poles

Conductor to Conductor Clearances - Crossings

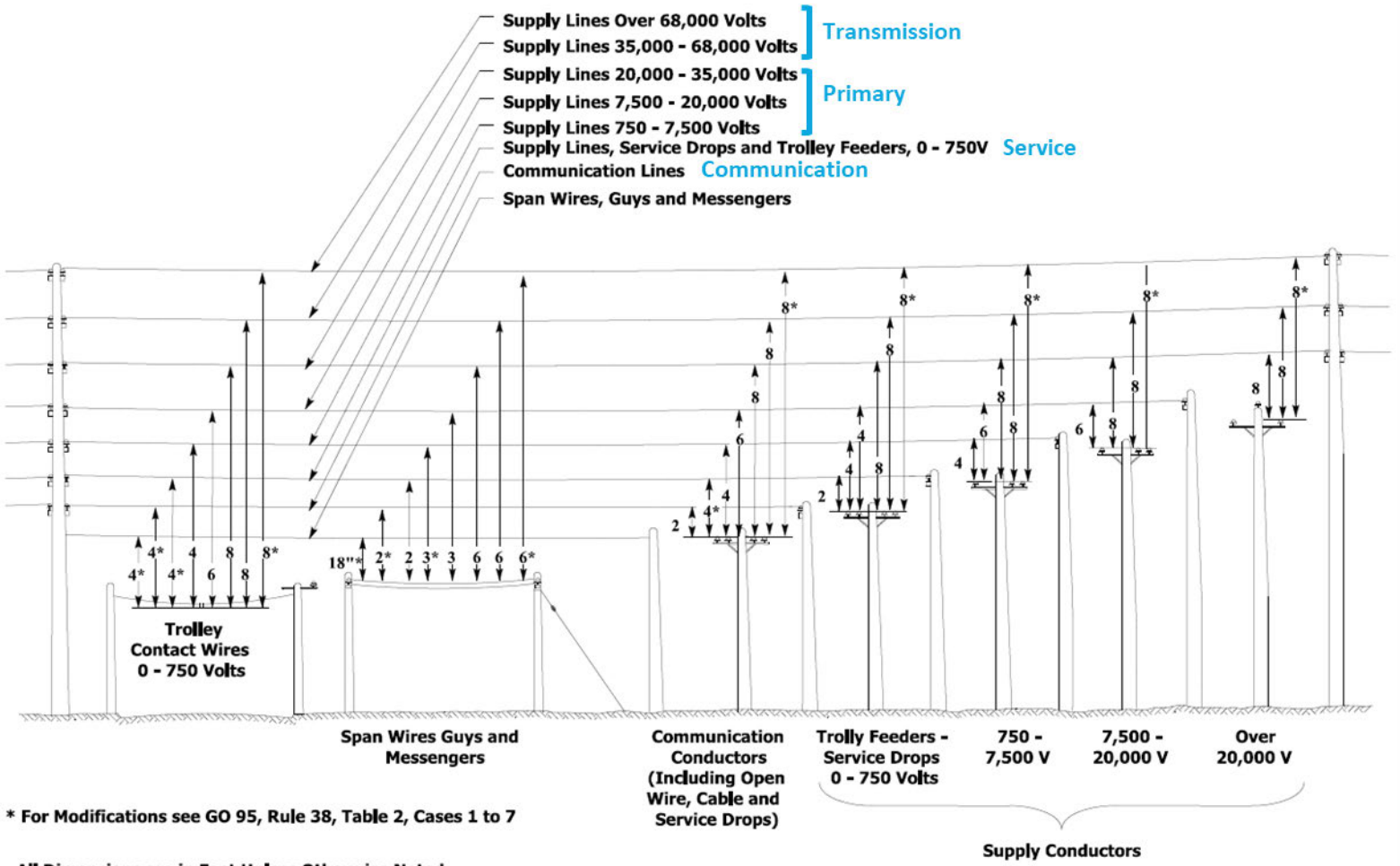

- 300kV plus transmission circuits require 156 inches of clearance to the primary.



Crossing Poles Clearances



Conductor to Building Clearances

Conductor to Building Clearances

Conductors Cannot Be in the Shaded Areas

V = Vertical
H = Horizontal

* For modifications see GO 95 Rule 37, Table 1

	Conductor Type					
	Guys	Service Drops (not Attached)	0-750 V Spans	750V-22.5kV	22.5 – 300kV	300-550kV
V (Walkable Surface)	8 ft. *	8 ft. *	8 ft.	12 ft.	12 ft.	20 ft. *
V (Non-Walkable Surfaces: Handrails, Chimneys, Patio Covers, etc.)	2 ft.	8 ft. *	8 ft. *	8 ft.	8 ft.	20 ft.
H		3 ft. *	3 ft. *	6 ft.	6 ft. *	15 ft. *

Service
Secondary
Primary
Transmission

Above Building Clearance



Alongside Building Clearance





Covered Conductor

Category 1 – Exposed energized portions on covered conductor

Exposed Primary Covered Conductor- Tree Wire

Guidance: Does covered conductor have any exposed conductor sections? Does the conductor have any exposed energized splices, connectors, flying bells, or any other components that are not covered?

Exclude tree wire that was built to standard at the time of installation.

Dead end covers and jumper covers are not necessary at transition poles between bare wire and tree wire.

Minor work: No

EC Notification: Yes

Ref: Numbered Documents:

- [061149](#): "Raptor Safe Construction and Wildlife Protection,
- [015195](#) - Installation Details for Aluminum, ACSR, and Copper Covered Tree Wire

A. Is there a mis-aligned, or installed and now missing Dead-End Cover, exposing the bare conductor?

1. (No) No action
2. (Yes) Repair/Replace F Tag



Example

MIS-ALIGNED DEAD-END COVERS	
	<p>At this Location: Dead-End Cover mis-aligned on tree wire construction.</p> <div style="display: flex; align-items: center; gap: 10px;"> <div style="border: 1px solid green; padding: 2px; width: 20px; height: 20px; display: flex; align-items: center; justify-content: center;"> </div> <div style="border: 1px solid blue; padding: 2px; width: 20px; height: 20px; display: flex; align-items: center; justify-content: center;"> </div> </div>
	<p>Perform Minor Work: Yes, if safe to do so. Install anti-rotation Clamp</p>
	<p>Write 3rd Party Notification: No</p>
	<p>Write EC Notification: Yes</p> <p>FDA= Dead End Cover / Broken / Damaged / Replace</p> <p style="text-align: center;">OR</p> <p>FDA= Dead End Cover / Broken / Damaged / Repair</p> <p>Priority = F Tag, depending on exposure</p>

B. Are there exposed energized splices, connectors, flying bells, or other components?

1. (No) No action
2. (Yes) Repair/Replace F Tag

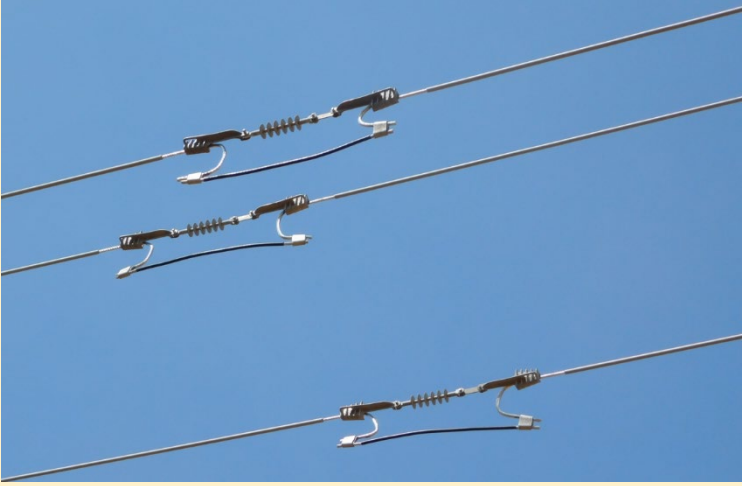

Example

Exposed Primary Covered Conductor – Flying Bells, Wedge Connectors not removed after Work	
	<p>At this Location: Flying Bells installed in on primary tree wire, now have exposed connectors and conductor.</p> <div style="display: flex; align-items: center; gap: 10px;">   </div>
Perform Minor Work: No	
Write 3rd Party Notification: No	
Write EC Notification: Yes	
FDA: Tree Wire / Exposed / Repair	
Priority: F Tag, depending on exposure	

C. Is the jacket/insulation burnt and exposing the conductor?

1. (No) No action
2. (Yes) Does burnt conductor have broken strand(s) or reduced cross sectional area?
 - a. (No) Repair/ Replace E Tag
 - b. (Yes) Repair/Replace Level IA or IIX

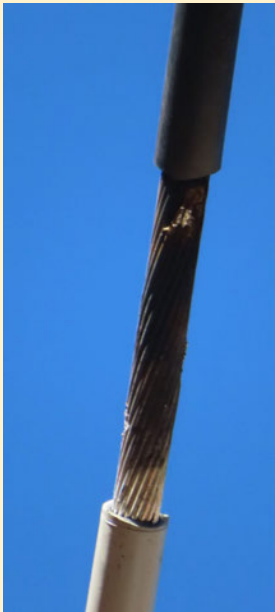
Example

Exposed Primary Covered Conductor Tree Wire, Burnt Conductor	
	<p>At this Location: Tree Wire conductor exposed and burnt.</p> <div style="display: flex; align-items: center; gap: 5px;">   </div>
	<p>Perform Minor Work: No</p>
	<p>Write 3rd Party Notification: No</p>
	<p>Write EC Notification: Yes</p> <p>FDA= Tree Wire / Exposed / Repair</p> <p>FDA= Conductor / Burnt / Repair</p> <p>Priority: E Tag, depending on exposure</p>

D. Is the covered conductor jacket cut into and bare conductor exposed?

1. (No) No action
2. (Yes) Broken strands present?
 - a. (No) Repair/Replace F Tag
 - b. (Yes) See, Does the Conductor have Broken Strands?

Example

Exposed Primary Covered Conductor Tree Wire	
	At this Location: Tree Wire jacket cut into, and bare conductor exposed
	Perform Minor Work: No
	Write 3rd Party Notification: No
	Write EC Notification: Yes
	FDA: Tree Wire / Exposed / Repair Priority: F Tag, depending on exposure

E. Splice covering, is splice exposed?



- a. (No) No action
- b. (Yes) Repair/Replace F Tag



Crossarm / Insulators / Cutouts



Framing



1. Crossarm Broken/Deteriorated

General Guidance: Refer to [Crossarm Evaluation Job Aid](#) in this document.

Cracked Cross-Arm – Aerial View	
	<p>At this Location: Top view of a cracked cross-arm on top and sides. May not be seen from the ground.</p> <p>   </p>
	<p>Perform Minor Work: No</p>
	<p>Write 3rd Party Notification: No</p>
	<p>Write EC Notification: Yes</p> <p>FDA = Cross-arm / Broken / Damaged / Replace</p> <p>Priority = X Tag, however extenuating circumstances may escalate to A Tag</p>

Deteriorated Cross-Arm – Aerial View	
	<p>At this Location: Top view of a Deteriorated/Rotten cross-arm. May not be seen from the ground. Quarter brace hardware coming loose.</p> <p style="text-align: center;"></p>
	<p>Perform Minor Work: No</p>
	<p>Write 3rd Party Notification: No</p>
	<p>Write EC Notification: Yes</p> <p>FDA = Cross-arm / Broken / Damaged / Replace</p> <p>Priority = Minimum B tag, consider A Tag for conditions such as conductor size, double / single arm, exposure, etc.</p>

Deteriorated Cross-Arm – Aerial View	
	<p>At this Location: Deteriorated Cross-Arm – Aerial View</p> <p style="text-align: center;"></p>
	<p>Perform Minor Work: No</p>
	<p>Write 3rd Party Notification: No</p>
	<p>Write EC Notification: Yes</p> <p>FDA = Cross-arm / Broken / Damaged / Replace</p> <p>Priority = Minimum B tag, consider A Tag for conditions such as conductor size, double / single arm, exposure, etc.</p>

Deteriorated Cross-Arm – Aerial View	
	<p>At this Location: Deteriorated/Rotten Cross-Arm – Aerial View</p> <p></p>
	<p>Perform Minor Work: No</p>
	<p>Write 3rd Party Notification: No</p>
	<p>Write EC Notification: Yes</p> <p>FDA = Cross-arm / Broken / Damaged / Replace</p> <p>Priority = Minimum B tag, consider A Tag for conditions such as conductor size, double / single arm, exposure, etc.</p>



Crossarm Evaluation Job Aid

General Information:

Environmental conditions throughout the service territory expose support structures to a variety of conditions that can cause or accelerate deterioration of wood components. This section provides guidelines for assessing wood crossarms.

General Guidance: During detailed inspections, examine wood crossarms and assess their condition: Is primary or secondary crossarm damaged, broken, burnt, decayed, rotten, loose, missing hardware or showing signs of bent bolts or brackets that cause the crossarm not to be horizontal, gun shots, insect damage or woodpecker damage, or splitting that compromises the integrity of the crossarm? If yes, create EC notification to replace crossarm; always consider replacing wood crossarms with composite.

Note: Bent crossarm brace alone is not a compelling issue.

Additional Guidance:

Identify conditions such as crossarm configuration, number of phases, location (e.g., urban, rural, forest, inaccessible, traffic, etc.), loading (e.g., double/triple arms, dead ends, alley arms, proximity to trees, angles/conductor size, heavy loading, damaged wood pins, etc.) and the likelihood of these conditions contributing to further deterioration or failure of the crossarm or attached components.

Often cross arms experience significant decay on the top of the arm without exhibiting clues that are visible from the ground¹. For this reason, arms that exhibit two or more of the following characteristics are more likely to decay on the top and should be considered for a more detailed aerial/climbing inspection:

- Arms that appear to be greater than 50 years old²(based on age of pole, presence of wood pins, brown/glass insulators, or other indicators).
- Arms mounted on poles where the pole top is showing signs of decay or crowning.
- Severely weathered arms or arms rounded or apparently decayed ends.
- Damaged wood pins or elongated pinholes.
- Active moss/vegetation growth.
- Presence of woodpecker holes (greater than one inch diameter) on the arm
- Arms in areas of higher rainfall/moisture and reduced sunlight such as those in many coast and mountain areas.
- Wood pins on arms located in agricultural areas or orchards contaminated by aerial spraying and dirt, which contributes to tracking and arm or pin deterioration.

¹ Examples of top and bottom views of crossarm conditions are shown in table 2.

² Many, but not all, arms prior to 1955 were untreated.

<p style="text-align: center;">BROKEN CROSSARM</p> <p>Crossarm is completely broken/fractured</p>  <p>Emergency - make safe immediately</p>	<p style="text-align: center;">SPLIT CROSSARM</p> <p>Primary Squatter (wood pin). Crossarm split within 2" of pinhole.</p>  <p>Replace in the next 3 months.</p>
<p style="text-align: center;">TOP OF CROSSARM DECAYED</p> <p>Evidence of pole top decay and face of crossarm decay; may need additional assessment of crossarm.</p>  <p>Replace 3-12 months</p>	<p style="text-align: center;">DETERIORATED CROSSARM</p> <p>Significant deterioration, both arms are broken/split. Evidence of previous temporary repair.</p>  <p>Replace 3-12 months</p>
<p style="text-align: center;">BROKEN SECONDARY CROSSARM</p> <p>Secondary arm broken; split/fractured within 2" of bolt holes in heavy tree area.</p>  <p>Replace 3-12 months</p>	Empty cell

Examples

Through Bolt Loose	
	
At this Location: The nut has come off of the Through Bolt	
Perform Minor Work: No	
Write 3rd Party Notification: No	
Write EC Notification: Yes	
FDA = Hardware / Loose / Adjust	
Priority = X Tag, depending on exposure	

Missing Hardware Impacting Integrity – Aerial View	
	
At this Location: The nut on the through bolt has come off of the king pin.	
Perform Minor Work: No	
Write 3rd Party Notification: No	
Write EC Notification: Yes	
FDA = Hardware / Loose / Adjust	
FDA = Pole / Rotten / Replace	
Priority = E Tag, depending on exposure	

Secondary Squatter and Decayed Crossarm	
	<p>At this Location: Secondary Squatter and decayed crossarm, replace wood crossarm with composite arm.</p>
	<p>Perform Minor Work: No</p>
	<p>Write 3rd Party Notification: No</p>
	<p>Write EC Notification: Yes</p> <p>FDA= Crossarm Decayed / Rotten / Replace</p> <p>FDA= Secondary Squatter / Broken / Damaged / Replace</p> <p>Priority= E Tag, at minimum, next inspection cycle; based on field condition and exposure, corrosion, etc.; prioritize as needed (A, B, E, or F)</p>

2. Bonding Exists and Needs to be Repaired



General Guidance: Visual observation of broken / unattached bonding wire on a cross-arm. Create EC notification.



Minor Work: No

EC Notification: Yes

Related Documents: [06667](#)

Example

BONDING	
	<p>At this Location: Broken or unattached bonding</p> <p> </p>
	<p>Perform Minor Work: No</p>
	<p>Write 3rd Party Notification: No</p>
	<p>Write EC Notification: Yes</p> <p>FDA = Bonding / Broken / Damaged / Replace</p> <p>Priority = E Tag, up to 36 months depending on exposure</p>

CONCENTRIC HAS COME LOOSE	
	<p>At this Location: Concentric has come loose and no longer connected to insulator.</p> <p>This Termination is not grounded, and leakage current is being carried on the semi con jacket of the cable. The distance between the concentric and porcelain termination should be minimal.</p> <p> </p>
	<p>Perform Minor Work: No</p>
	<p>Write 3rd Party Notification: No</p>
	<p>Write EC Notification: Yes</p> <p>FDA: Ground / Missing/ Install</p> <p>FDA: Riser / Pothead broken / Damaged / Replace</p> <p>Priority: Minimum F Tag, depending on exposure</p>



3. Underarm Bus Not Securely Attached

General Guidance:

It is a requirement to have at least two attachment points, secured to an underarm bus, one on each side.

It is a requirement to use the following corrosion resistant materials for attaching the underarm bus to the crossarm: straps, plumber's tape, lags, galvanized nails, staples, screws, bolts, zip ties, etc.

If an inspector finds an underarm bus secured with non-authorized material, such as duct tape, electrical tape, or rope, it must be secured by at least two additional approved attachment points.

When an inspector re-secures a bus, it must be brought up to construction standards; four attachment points using corrosion resistant materials.

Complete as minor work/re-secure the bus. IF it cannot be completed as minor work, then create EC notification if compelling and needs to be addressed within 5 years.



Minor Work: Yes



EC Notification: Yes, only if not able to perform minor work.

Select the Priority and Due Date based upon compelling abnormal condition that may adversely impact public safety and/or service reliability.

Related Documents: [021924](#), [Crossarm Evaluation](#)

Examples

Under-Arm Bus Loose and Deteriorated	
	
<p>At this Location: UAB deteriorated, partial repair with rope, secured with one strap.</p>	
 	
<p>Perform Minor Work: No</p>	
<p>Write 3rd Party Notification: No</p>	
<p>Write EC Notification: Yes</p>	
<p>FDA=Under-Arm Bus / Broken / Damaged / Repair</p>	
<p>Priority = At minimum – must write up as F Tag, next inspection cycle; based on field condition and exposure, corrosion, etc.; prioritize as needed (A, B, E, or F)</p>	

UNDER-ARM BUS LOOSE	
	<p>At this Location: UAB Loose, unattached and hanging.</p>
	<p> </p>
	<p>Perform Minor Work: No</p>
	<p>Write 3rd Party Notification: No</p>
	<p>Write EC Notification: Yes</p> <p>FDA= Under-Arm Bus / Broken / Damaged / Repair</p> <p>Priority= E Tag, depending on exposure</p>



Insulators

1. Damaged Insulators

General Guidance Are Insulators chipped, cracked, corroded, severely contaminated to the point of tracking, flashed, or have signs of tracking/arcing, broken, or damaged? If yes, create EC notification.

Replace ALL insulators if one is chipped, cracked, contaminated, broken, or damaged. **Do Not** mismatch insulators.

Note for construction: If an insulator is damaged due to gunshot, replace with epoxy or polymer insulators.

Note for construction: Cannot mix insulator types, always replace full set of insulators.

Note: Inspector should always consider replacing wood crossarm with composite crossarm, based on condition of crossarm.

Minor Work: No



EC Notification: Yes



Select the Priority and Due Date based upon compelling abnormal condition that may adversely impact public safety and/or service reliability.



Related Documents: [022088](#), [068180](#) (composite crossarm), [Crossarm Evaluation Job Aid](#) in this document.

Examples

DAMAGED INSULATOR	
<p>At this Location: Damaged insulator, Replace all insulators and the arm.</p>	
<div style="display: flex; align-items: center; gap: 10px;"> <div style="background-color: #90EE90; padding: 5px; width: 30px; height: 30px; display: flex; align-items: center; justify-content: center;"> </div> <div style="background-color: #ADD8E6; padding: 5px; width: 30px; height: 30px; display: flex; align-items: center; justify-content: center;"> </div> </div>	
<p>Perform Minor Work: No</p>	
<p>Write 3rd Party Notification: No</p>	
<p>Write EC Notification: Yes</p> <p>FDA= Crossarm / Decayed/Rotten / Replace</p> <p>FDA= Insulator / Broken / Damage / Replace</p> <p>Priority= E Tag, depending on exposure</p>	

FLASHED INSULATOR POTHEAD	
	<p>At this Location: Flashed pothead</p> <p> </p>
	<p>Perform Minor Work: No</p>
	<p>Write 3rd Party Notification: No</p>
	<p>Write EC Notification: Yes, or COE (see a set of combo cutouts at location follow COE process)</p> <p>FDA= Riser / Pothead / Flashed / Replace</p> <p>Priority= F Tag At minimum, next inspection cycle; based on field condition and exposure, corrosion, etc.; prioritize as needed (A, B, E, or F)</p>

CONTAMINATED INSULATOR	
	<p>At this Location: Significant contamination, no signs of tracking</p> <p> </p>
	<p>Perform Minor Work: No</p>
	<p>Write 3rd Party Notification: No</p>
	<p>Write EC Notification: Yes</p> <p>FDA= Insulator / Broken / Damaged / Replace</p> <p>Priority= E Tag, depending on exposure</p>

BROKEN SECONDARY INSULATOR	
	
<p>At this Location: Broken secondary insulator. Strain is controlled by the second insulator on the Double arm construction.</p>	
 	
<p>Perform Minor Work: No</p>	
<p>Write 3rd Party Notification: No</p>	
<p>Write EC Notification: Yes</p> <p>FDA= Crossarm / Decayed / Rotten / Replace</p> <p>FDA= Insulator / Broken/ Damage / Replace</p> <p>Priority= E Tag, depending on exposure</p>	

CONTAMINATED INSULATOR	
	<p>At this Location: Significant contamination, no signs of tracking</p> <div style="display: flex; justify-content: space-around;">   </div>
	<p>Perform Minor Work: No</p>
	<p>Write 3rd Party Notification: No</p>
	<p>Write EC Notification: Yes FDA= Insulator / Broken / Damaged / Replace Priority= E Tag, depending on exposure</p>

2. Squatters – Primary or Secondary

General Guidance: Are primary or secondary insulators squatting? If yes, create EC Notification.

Minor Work: No

EC Notification: Yes



Select the Priority and Due Date based upon compelling abnormal condition that may adversely impact public safety and/or service reliability.



Notes:

- Inspector should always consider replacing wood crossarm with composite crossarm when needed.

Related Documents: [022088](#), [Crossarm Evaluation](#)

Example

Primary Squatter	
	<p>At this Location: 2 Primary wood pin squatters, replace wood crossarm with composite arm.</p> <p> </p>
	<p>Perform Minor Work: No</p>
	<p>Write 3rd Party Notification: No</p>
	<p>Write EC Notification: Yes</p> <p>FDA= Crossarm Decayed / Rotten / Replace</p> <p>FDA= Insulator / Primary Squatter / Replace</p> <p>Priority= E Tag, at minimum, next inspection cycle; based on field condition and exposure, corrosion, etc.; prioritize as needed (A, B, E, or F)</p>

Secondary Squatter, Crossarm in good shape	
	<p>At this Location: Secondary Squatter, crossarm in good shape</p> <p> </p>
	<p>Perform Minor Work: No</p>
	<p>Write 3rd Party Notification: No</p>
	<p>Write EC Notification: Yes</p> <p>FDA= Secondary Squatter / Broken / Damaged / Replace</p> <p>Priority= E Tag, depending on exposure</p>



3. Flying Bells

General Guidance: Are flying bells broken or damaged? If yes, create EC notification.

Note: If flying bells were installed to de-energize idle facilities, assess vegetation around idle conductor; create EC notification to trim, as vegetation management does not perform trimming on idle facilities.

Minor Work: No

EC Notification: Yes

Select the Priority and Due Date based upon compelling abnormal condition that may adversely impact public safety and/or service reliability.

Refer to the [Glossary](#) for Flying Bell picture.

4. Cotter Key



General Guidance: Loose or missing condition, Is Retainer Pin fully seated? Use binoculars. If observed, create EC Notification.

Minor Work: No

EC Notification: Yes

Select the Priority and Due Date based upon compelling abnormal condition that may adversely impact public safety and/or service reliability.

Example

MISSING COTTER KEY / RETAINER PIN FULLY SEATED	
	<p>At this Location: Missing Cotter Key / Retainer Pin Fully Seated, may fall out.</p> <p> </p>
	<p>Perform Minor Work: No</p>
	<p>Write 3rd Party Notification: No</p>
	<p>Write EC Notification: Yes FDA= Hardware / Missing / Install Priority= B Tag, depending on exposure</p>

COTTER KEY BACKED OUT	
	<p>At this Location: Cotter Key partially backed out.</p> <p> </p>
	<p>Perform Minor Work: No</p>
	<p>Write 3rd Party Notification: No</p>
	<p>Write EC Notification: Yes FDA= Hardware / Loose / Adjust Priority= E Tag, depending on exposure</p>

RETAINER PIN COMING LOOSE, ALMOST PULLED OUT



At this Location: Retainer Pin coming loose, almost pulled out.



Perform Minor Work: No

Write 3rd Party Notification: No

Write EC Notification: Yes

FDA = Hardware / Loose / Adjust

Priority = A Tag, Follow emergency procedure



Cutouts / Fuses / Switches

1. Damaged Arcing Horns

General Guidance: Call Restoration Dispatch to get a T-Man dispatched to the location to create a COE (CE) notification. Consider installing a warning tag on the pole.

Minor Work: No

EC Notification: No

Related Documents: [015225](#), [066195](#)

2. Cutouts

General Guidance: Are cutouts broken, damaged, cracked, loose, **severely contaminated to the point of tracking** or flashed?

Guidance: Yes/No, if yes, THEN create an EC Notification.



Minor Work: No

EC Notification: Yes

Select the Priority and Due Date based upon compelling abnormal condition that may adversely impact public safety and/or service reliability.

Related Documents: [015225](#)

Examples

<p>BROKEN DAMAGED CROSSARM MOUNTED CUTOUT</p>	<p>BROKEN CUTOUT</p>
	
<p>At this Location: Broken/Flashed cutout, ensuring bond wire is attached to the bracket.</p>	<p>At this Location: Broken Cutout</p>
<p>Perform Minor Work: No</p>	<p>Perform Minor Work: No</p>
<p>Write 3rd Party Notification: No</p>	<p>Write 3rd Party Notification: No</p>
<p>Write EC Notification: Yes</p> <p>FDA = Cutout / Broken / Damaged / Replace</p> <p>Priority = E Tag, depending on exposure, no COE</p>	<p>Write EC Notification: Yes</p> <p>FDA = Cutout / Broken / Damaged / Replace</p> <p>Priority = A Tag, Follow the emergency process</p>

3. Fuses

General Guidance: Are the Fuses corroded on the mountings or end fittings, red cap missing (E Fuse only), paint finish is flaking or cracked, fiberglass layer exposed, E Fuse found hanging upside down (E Fuse only), missing components, cracks, deterioration, burnt, charring, or blown? Do liquid fuses have the appropriate fluid level?

Minor Work: No

EC Notification: Yes

Liquid Filled Fuses (Per TD-2305M-JA14):

General Guidance:

- Low, missing, or undetermined liquid in HFTD
 - Create EC tag with **Priority B (180 days)** to replace liquid fuse element with approved ELF-LR
- Low, missing, or undetermined liquid in non-HFTD
 - Create EC tag with **Priority E (1 year)** to replace liquid fuse element with approved ELF-LR

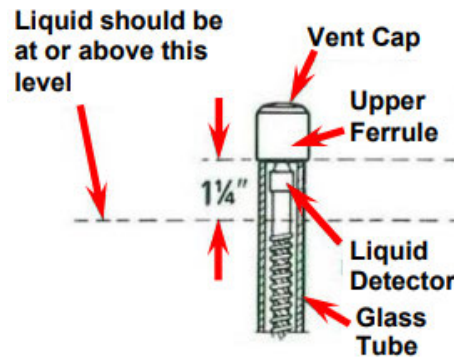





Size 1
7.5 kV and 23 kV

Select the Priority compelling abnormal adversely impact reliability.

due date based upon conditions that may public safety and/or service

Related Doc: [015225](#), [TD-2908P-01-JA260](#), [TD-2908P-01-JA261](#), [TD-2305M-JA14](#), [TD-2908P-01-JA243](#)



Examples

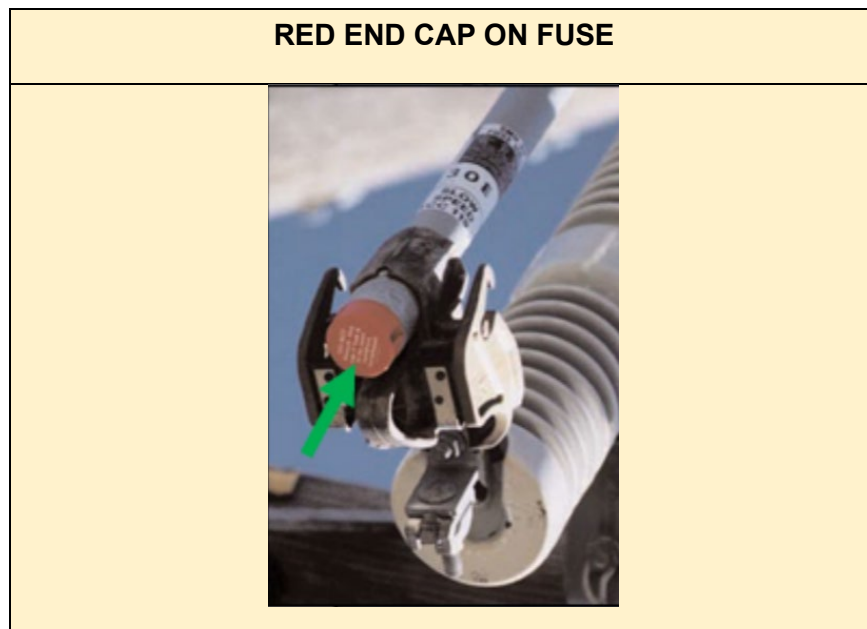

PART 63 POWER FUSE	PART 75 FAULT TAMER
	
<p>At this Location: Fuse End fitting excessively corroded; fiberglass layer exposed.</p> 	<p>At this Location: Excessive cutout corrosion leading to corrosion on the metal components of the FT Fuse, deteriorated housing on the FT Fuse will not contain an arc withing the snuffing tube. Any reasonable suspicion of damage that will not be able to operate correctly.</p> 
<p>Perform Minor Work: No</p>	<p>Perform Minor Work: No</p>
<p>Write 3rd Party Notification: No</p>	<p>Write 3rd Party Notification: No</p>
<p>Write EC Notification: Yes</p> <p>FDA = Cutout / Broken / Damaged / Replace</p> <p>And</p> <p>FDA= Fuse / Broken / Damaged / Replace</p> <p>Priority = E Tag, depending on exposure</p>	<p>Write EC Notification: Yes</p> <p>FDA = Cutout / Broken / Damaged / Replace</p> <p>And</p> <p>FDA= Fuse / Broken / Damaged / Replace</p> <p>Priority = E Tag, depending on exposure</p>

General Guidance: Inspect fuses, mountings, and end findings:

- If there are severe corrosion or wear on the metal components of the mounting or the end-fittings of the fuse unit, the mounting of the end-fittings must be replacing. The fuse unit should be removed from the mounting and inspected. If there is severe corrosion on the fuse unit, it must be removed from service and replaced with a new fuse unit.
- If the red rain cap is missing at the end of the fuse unit installed in outdoor applications, the fuse unit must be removed from service and be replaced with a new fuse unit.
- If a fuse unit's paint finish is flaking or has become cracked or if the underlaying fiberglass layer is exposed, the fuse unit must be removed from service and replaced with a new fuse unit.
- If fuse is hanging upside down (E fuse only), missing components, cracks, deterioration, burnt, charring or blown?
- Do liquid fuses have the appropriate fluid level?



FUSE	
	<p>At this Location: Liquid fuse is low.</p> <div style="display: flex; justify-content: space-around;">   </div>
	<p>Perform Minor Work:</p>
	<p>Write 3rd Party Notification:</p>
	<p>Write EC Notification: Yes</p> <p>FDA = Cutout / Broken/Damaged / Replace</p> <p>And</p> <p>FDA= Fuse / Broken / Damaged / Replace</p> <p>Priority = E Tag, depending on exposure</p>

Arcing horn with burnt tip	
<div style="border: 1px solid black; padding: 2px; width: fit-content; margin-bottom: 5px;">Arcing horn with burnt tip</div> 	<p>At this Location: Arcing horn with burnt tip, also has broken insulator.</p> <div style="display: flex; justify-content: space-around;">   </div>
	<p>Perform Minor Work: No</p>
	<p>Write 3rd Party Notification: No</p>
	<p>Write EC Notification: No</p> <p>FOLLOW COE PROCESS</p>



California Power Line Fire Prevention Field Guide

[California Power Line Fire Prevention Field Guide](#)

Miscellaneous Other Compelling Abnormal Conditions Guys / Anchors

Down Guy Preform Buried

General Guidance:

Top of anchor head must be above grade. Expose top of anchor head as minor work. Evaluate the unburied anchor guy pre-forms and visually inspect them.

Perform minor work to add extension or grade around anchor so the anchor head becomes visible.

If the pre-form cannot be unburied as minor work, create an EC notification.

Notes:

- A. If you cannot dig up the top of the anchor head, create an EC with a photo of a buried anchor **only**; you should make every effort to dig up the top of the anchor head to perform a complete assessment. If your photo is of a buried anchor head only, the general rule of thumb is that the EC will be created to **replace** the anchor.
- B. If you are performing an Overhead Inspection, and you cannot dig up a deeply buried anchor head, for example, cannot see the preform, the assumption is the anchor is too deep to expose. Create and EC to replace the anchor.
- C. The type of construction will determine the priority of the tag, for example:
 - Prioritize higher.
 - Large wire on a dead end or angle construction
 - Prioritize Lower
 - Small wire on dead end or angle construction

Minor Work: Yes





- Perform minor work if possible and if safe to do so.
- IF not able to perform minor work, THEN create EC notification.

EC Notification: Yes

Select the Priority and Due Date based upon compelling abnormal condition that may adversely impact public safety and/or service reliability.

Related Documents: [022221](#)

Examples

BURIED ANCHOR	
	
<p>Before: Vegetation covers anchor</p> <p>After: Vegetation cleared from anchor</p>	
<p>At this Location: Anchor head below grade overgrown with vegetation. After minor work inspector decides if the anchor can be adjusted or needs replaced.</p> <div style="display: flex; gap: 10px;">   </div>	
<p>Perform Minor Work: Yes, remove the vegetation. Yes, expose the top of the anchor head and evaluate condition/corrosion. Yes, preferred method is to adjust anchor by adding extension</p>	
<p>Write 3rd Party Notification: No</p>	
<p>Write EC Notification: Yes, if cannot be addressed as minor work. FDA= Anchor / Soil/Eroded/Graded / Replace (if the anchor cannot be adjusted)</p>	
<p>Priority= F Tag at minimum – must write up as, next inspection cycle; based on field condition and exposure, corrosion, etc.; prioritize as needed (A, B, E, or F)</p>	

ANCHOR EXTENSION



Anchor extension



Close-Up

At this Location: Inspector performed minor work, exposed anchor, evaluated anchor to be in good condition so that extension could be installed, then installed extension. (Back fill not shown)



Perform Minor Work: Yes



Write 3rd Party Notification: No

Write EC Notification: No



ANCHOR COVERED BY CONCRETE	
	<p>At this Location: Anchor covered by concrete.</p> <div style="display: flex; gap: 5px;"> <div style="border: 1px solid black; background-color: #c8e6c9; padding: 2px; text-align: center;">  </div> <div style="border: 1px solid black; background-color: #bbdefb; padding: 2px; text-align: center;">  </div> </div>
	<p>Perform Minor Work: No</p>
	<p>Write 3rd Party Notification: No</p>
	<p>Write EC Notification: Yes</p>
	<p>FDA= Anchor / Soil / Eroded /Graded / Replace</p> <p>Priority= F Tag at minimum, next inspection cycle; based on field condition and exposure, corrosion, etc.; prioritize as needed (A, B, E, or F)</p>



ANCHOR BURIED BY VEGETATION		
Anchor buried by tree		
		
<p>At this Location: Anchor buried by ivy roots / tree.</p>		
<p> </p>		
<p>Perform Minor Work: No</p>		
<p>Write 3rd Party Notification: No</p>		
<p>Write EC Notification: Yes</p> <p>FDA=Anchor / Soil / Eroded / Graded / Replace</p> <p>Priority= F Tag at minimum, next inspection cycle; based on field condition and exposure, corrosion, etc.; prioritize as needed (A, B, E, or F)</p>		

Visible Portion of Anchor Rod has Significant Corrosion

General Guidance: IF the visible portion of the anchor rod is significantly corroded, where there's loss of material or pitting, THEN create EC notification.





Minor Work: No

EC Notification: Yes

Select the Priority and Due Date based upon compelling abnormal condition that may adversely impact public safety and/or service reliability.

Related Documents: [025998](#)

Examples

ANCHOR ROD WITH SIGNIFICANT CORROSION	
Anchor above ground	Below
	
<p>At this Location: Corroded Anchor, with material loss. See “penciling” in photo.</p>	
<p> </p>	
<p>Perform Minor Work: No</p>	
<p>Write 3rd Party Notification: No</p>	
<p>Write EC Notification: Yes</p> <p>FDA= Anchor / Corroded / Replace</p> <p>Priority= E Tag, depending upon exposure</p>	

Guy Broken / Slack / Corroded

General Guidance: Important: Before any work is performed on a down guy, inspect the guy insulator; if broken, check for presence of voltage (with dead tester). Pole must be straight with Guy no more than an arm's length (3ft) from taut, that does not have significant impact on the structural integrity of the pole. Tighten the guy as minor work if possible. If not possible, create an EC Notification.

If tightening the guy would exacerbate any pre-existing conditions on a facility (e.g., increase the lean of an already leaning pole, deform an already deforming pole), create an EC Notification with comments describing the situation.

Minor Work: Yes

EC Notification: Yes

Select the Priority and Due Date based upon compelling abnormal condition that may adversely impact public safety and/or service reliability.

Related Documents: [022178](#), [ATS Report: 006.4.2-23.9](#)

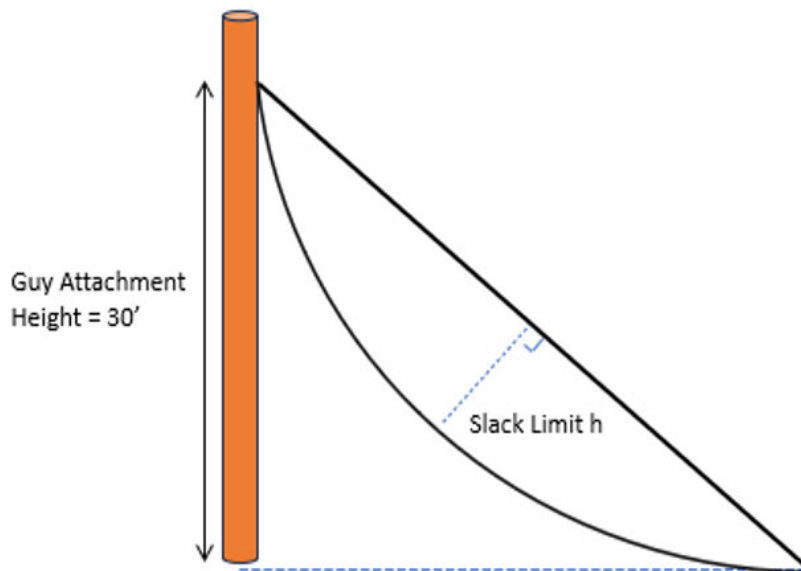

Examples

GUY SLACK	
	<p>At this Location: Guy is slack more than arm length. Pole is affected by slack guy.</p> <div style="display: flex; align-items: center; gap: 10px;"> </div>
	<p>Perform Minor Work: Yes, if safe to do so and equipped with appropriate tools.</p>
	<p>Write 3rd Party Notification: No</p>
	<p>Write EC Notification: Yes, if not completed by minor work</p> <p>FDA= Guy / Loose / Adjust</p> <p>Priority= F Tag, depending on exposure.</p>

Guy Clearance Issue

General Guidance: Guys in the cylinder of “proximity” to conductors less than 35kV:

Note: Items in **bold** are most applicable to GO 165 inspections.

- a) A guy is in “proximity” if any portion of the guy is both within a vertical distance of less than 8 feet from the level of the supply conductors, and a radial distance of less than 6 feet from the surface of a wood pole or structure.
- b) A guy is “exposed” if any portion of the guy is less than 8 feet horizontally from the vertical plane of any supply conductor of more than 250 volts.

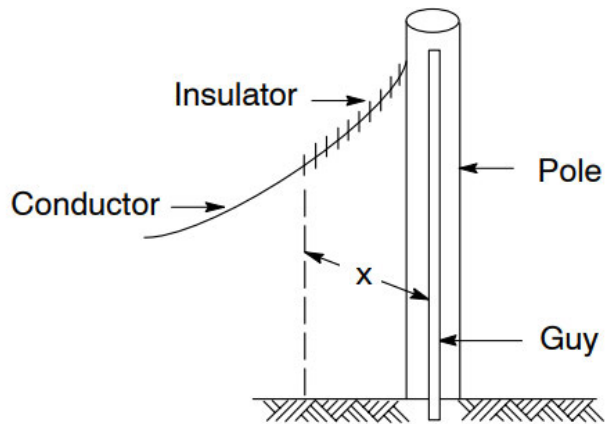

If distance “x” is less than 8’, guy is exposed.

If a guy is exposed to any supply conductor of 22,500 volts or more, it will not be sectionalized and shall be securely grounded. All other guys, including overhead guys and guys in the proximity (i.e., cylinder of proximity), shall be sectionalized.

- c) Any two anchor or overhead guys attached to the same wood pole, which are approximately parallel to each other and act in the same direction, should be separated at the points of attachment to the pole by approximately 12 inches if either of the guys is sectionalized. The purpose of this separation is to maintain a minimum separation of 3 inches between the surface of a strain insulator in one guy and the surface of the other guy. If this minimum separation of 3 inches is not obtained by the 12-inch separation at pole, use other means, such as greater separation than 12 inches, or attachment to separate anchors. This rule does not prohibit the



two guys from contacting the same strain plate, nor does it prohibit attaching guys not acting in the same direction to the same through bolt.

- d) Not more than two guys, having a vertical separation of 18 inches or less, can be installed in any 4-foot section of climbing space.
- e) Overhead guys less than 17 feet long with neither end grounded, shall be sectionalized by installing one insulator approximately midway between points of attachment, in place of two insulators between 6 and 9 feet from each end.
- f) Place sectionalizing insulators in guys as high as permissible, giving due consideration to the future installation of additional supply circuits. This is necessary to prevent the grounding of the upper end of such guys by the future installation of grounded telephone cables, tree growth, etc.
- g) Guys may be grounded by connecting them to a metallic anchor rod, a securely grounded steel pole, a ground rod, or another grounded guy.
- h) The requirements for grounding or sectionalizing sidewalk and truss guys, and the conditions under which they may be grounded, are the same as for anchor guys. Braces for these guys which fall within cylinders of proximity (i.e., braces that are less than 8 feet below supply conductors of 0–35,500 V), must not be grounded.
- i) **Those portions of guys that are more than 6 inches from the surface of wood poles or crossarms (measured from the point of attachment along the guy) shall clear transformer cases and hangers by not less than 4 inches. Those portions that are less than 6 inches from the surface of wood poles or crossarms shall clear transformer cases and hangers by not less than 1-1/2 inches.**
- j) **Guys in climbing space may not be closer than 1-1/2 inches to any through bolt that is mechanically connected to dead-end hardware. Guys and guy attachments shall clear ground wires and metal riser conduits for supply cables by 1-1/2 inches minimum.**





Minor Work: No

EC Notification: Yes

Select the Priority and Due Date based upon compelling abnormal condition that may adversely impact public safety and/or service reliability.



Related Documents: [022178](#)

Examples

GUY CLEARANCE	GUY DAMAGED REPAIR
	
<p>At this Location: Acceptable solution through plastic barrier</p> 	<p>At this Location: Guy tail extends beyond the preform, <u>Near sidewalk, safety hazard.</u></p> 
<p>Perform Minor Work: No</p>	<p>Perform Minor Work: Yes, if safe to do so</p>
<p>Write 3rd Party Notification: No</p>	<p>Write 3rd Party Notification: No</p>
<p>Write EC Notification: No</p>	<p>Write EC Notification: Yes, only if unable to perform minor work.</p> <p>FDA= Guy / Broken / Damaged / Repair</p> <p>Priority= E Tag, depending upon exposure</p>

OVERGROWN GUY	TREE GROWING AROUND GUY
	
<p>At this Location: Extensive dead ivy covering half of length of guy, below the bob. Write EC Notification if there is damage to the guy.</p>  	<p>At this Location: Tree growing around guy, below the bob.</p>  
<p>Perform Minor Work: No</p>	<p>Perform Minor Work: No</p>
<p>Write 3rd Party Notification: No</p>	<p>Write 3rd Party Notification: No</p>
<p>Write EC Notification: Yes</p> <p>FDA= Guy / Broken / Damaged / Replace</p> <p>Priority= Minimum F Tag, depending upon exposure</p>	<p>Write EC Notification: Yes</p> <p>FDA= Guy / Broken / Damaged / Replace</p> <p>Priority= Minimum F Tag, depending upon exposure</p>

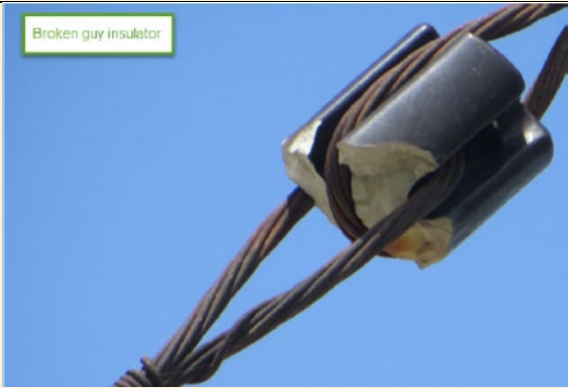

TREE LIMB GROWING AROUND GUY	
Guy through tree	Close-Up
	
<p>At this Location: Tree limb growing around guy, below the bob</p>	
<p>Perform Minor Work: No</p>	
<p>Write 3rd Party Notification: No</p>	
<p>Write EC Notification: Yes</p>	
<p>FDA= Guy / Broken / Damaged / Replace</p>	
<p>Priority= Minimum F Tag, depending upon exposure</p>	

BROKEN GUY INSULATOR	
	At this Location: Broken guy insulator
	Perform Minor Work: No
	Write 3rd Party Notification: No
	Write EC Notification: Yes FDA= Guy / Broken / Damaged / Replace
	Priority= E Tag, depending upon exposure

GUY CORRODED AND MISSING STRANDS	
	
At this Location: Guy corroded and missing strands	
Perform Minor Work: No	
Write 3rd Party Notification: No	
Write EC Notification: Yes FDA= Guy / Corroded / Replace	
Priority= Minimum F Tag, depending on exposure.	



Down Guy Grounded above Guy Insulator (vegetation or other)

General Guidance: Ensure that all guys are not grounded above the guy insulator. Remove any foreign objects (e.g., vegetation) contacting and grounding the guy above the insulator as minor work. Clear so that new growth will not contact or ground the guy.

Rule of thumb is that growth per year is 1 foot, so trim back 5 feet.





Minor Work: Yes

EC Notification: Yes





Select the Priority and Due Date based upon compelling abnormal condition that may adversely impact public safety and/or service reliability.

Related Documents: [022178](#)

Examples

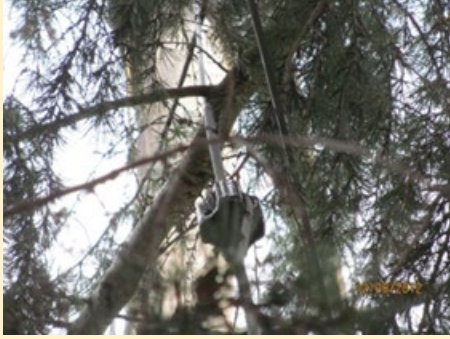
DOWN GUY GROUNDED ABOVE GUY INSULATOR	DOWN GUY GROUNDED ABOVE GUY INSULATOR CAUSING STRAIN AND ABRASION
	
<p>At this Location: Vine growing up and across the guy insulator grounding the guy.</p> 	<p>At this Location: Tree grounding the guy above the guy insulator causing strain and abrasion.</p> 
<p>Perform Minor Work: Yes</p>	<p>Perform Minor Work: Yes</p>
<p>Write 3rd Party Notification: No</p>	<p>Write 3rd Party Notification: No</p>
<p>Write EC Notification: Yes, only if minor work cannot be performed. FDA=Guy / Overgrown / Trim Priority= E Tag, 3-12 months depending upon exposure</p>	<p>Write EC Notification: Yes, only if minor work cannot be performed. FDA=Guy / Strain/Abrasion / Remove FDA=Guy / Overgrown / Trim Priority= E Tag, 3-12 months depending upon exposure</p>



GUY GROUNDED BY VEGETATION		
Guy grounded. by vegetation	Guy grounded. by vegetation	Guy overgrown by vegetation
		
<p>At this Location: Guy grounded by vegetation, above the bob.</p> <p> </p>		
<p>Perform Minor Work: Yes</p>		
<p>Write 3rd Party Notification: No</p>		
<p>Write EC Notification: Yes, only if minor work cannot be performed.</p> <p>FDA=Guy / Overgrown / Trim</p> <p>Priority= E Tag, depending upon exposure</p>		



Down Guy Marker Missing/Damaged

General Guidance: For poles installed with down guys:

- **After 1996**, Guy Markers are required on **all** down guys. The markers must be a minimum 8 ft. in length.
- **Prior to 1996**, guy markers are **only required** on poles which are exposed to traffic. Inspector should confirm the age of the pole via the date nail to verify the requirement.

Install a single guy marker on multiple guys which are clamped together. For guys that are not clamped together, but on the same anchor, consider separate guy markers on each guy if the separation is large.

Note 1: Installing yellow colored guy marker does not negate the need to install visibility strips on the markers. Install visibility strips around traffic areas, on state highways, near curbs, driveways, etc.

Note 2: For existing guy markers, ensure markers are in good condition and attached securely.

See details below:

Reflective visibility strips shall be installed on wood, fiberglass, or steel poles, streetlight poles, and guy markers as follows:

- A. On poles and guy markers installed on state highways.
- B. On poles and guy markers located within 15 feet from the paved surface or 15 feet from the edge of the traveled, unpaved portion of city or county roads (streets) where not protected by curbs.
- C. On poles and guy markers within 6 feet of an adjacent driveway, private roadway (street), turnaround, parking lot, or thoroughfare in rural district, capable of being traversed by vehicles, where these are not protected by curbs.

Note: Install a segment of guy marker above cattle guards to ensure a minimum 8 ft. of guarding.

Minor Work: Yes

EC Notification: Yes

Select the Priority and Due Date based upon compelling abnormal condition that may adversely impact public safety and/or service reliability.

Related Documents: [022178](#)



Examples

GUY MARKER MISSING	CATTLE GUARD LESS THAN 8 FT
	
<p>At this Location: Guy marker missing.</p> 	<p>At this Location: Cattle guard is less than 8 feet in length.</p> 
<p>Perform Minor Work: Yes, install new guy marker</p>	<p>Perform Minor Work: Yes, lower cattle guard and add guy marker to meet 8 feet requirement.</p>
<p>Write 3rd Party Notification: No</p>	<p>Write 3rd Party Notification: No</p>
<p>Write EC Notification: No, perform minor work. If minor work cannot be performed FDA=: Guy Marker / missing / Install or replace Priority=: F Tag</p>	<p>Write EC Notification: No, perform minor work. If minor work cannot be performed FDA= Guy Marker / missing / Install or replace Priority= F Tag</p>

MISSING MARKER AND VISUAL STRIPS





At this Location: Missing marker and visual strips. After marker is fixed, visual strips are still missing. Evidence of tire marks on anchor.



Perform Minor Work: Yes, add guy marker and reflective vis strips (use standard language around minor work)

Write 3rd Party Notification: No

Write EC Notification: Yes, if cannot bring up to standard with minor work.

FDA= Guy Marker/Missing/Install

Priority= Minimum F tag depending on exposure



Grounds / Ground Molding

Ground is considered exposed when:

- Can physically touch it with hand or tool.
- Can see the ground conductor.
- Covered ground situation where the insulation is cut into.

Exposed Ground Below 8'

General Guidance: Exposed PG&E owned grounds 8 feet or less from the ground must be covered.

- Inspectors must make every effort to cover the ground as minor work.
- If the exposed ground can be completed as minor work - preferred repair method is to use 1-1/2-inch plastic molding and not wood molding; if wood molding is used to make repair, use straps and not staples.
- Gaps in between molding segments should be covered if, in the inspector's judgment, they are large enough to allow human contact.

Consider a higher priority based on how much of the ground is exposed, and on the amount of public exposure. Inspector should “make safe” if cannot be addressed as minor work, based on location and exposure to the public.

The correct FDA is **Ground / Exposed / Repair** and **NOT** Molding Broken/damaged/repair or replace.



Minor Work: Yes

EC Notification: Yes

Select the Priority and Due Date based upon compelling abnormal condition that may adversely impact public safety and/o service reliability.

Related Documents: [TD-2990P-01](#)

Examples

EXPOSED GROUND	
	<p>At this Location: Exposed grounds near sidewalk.</p> <div style="display: flex; align-items: center;">   </div>
	<p>Perform Minor Work: Yes, at minimum make safe</p>
	<p>Write 3rd Party Notification: No</p>
	<p>Write EC Notification: Yes</p> <p>FDA=Ground / Exposed / Repair</p> <p>Priority= A Tag, emergency – due to High public exposure at ground level. (Incorporate X tag if in areas of no or low public exposure.)</p>

REPAIR WITH 1.5" MOLDING



Before: Copper Wire sticking out from under the wood molding



After: 1.5-inch u-shaped molding installed over existing wood molding

At this Location: Wood molding with ground exposed





Perform Minor Work: Yes

Write 3rd Party Notification: No

Write EC Notification: Only if not able to perform minor work.

FDA= Ground / Exposed / Repair

Priority = A Tag, Emergency due to **High** public exposure below 8' on sidewalk

REPAIR WITH 2" PLASTIC	REPAIR WITH WOOD MOLDING
	
<p>At this Location: Condition acceptable after repair of exposed ground</p> <div data-bbox="120 877 253 940"> </div>	<p>At this Location: Condition acceptable after repair with wood molding</p> <div data-bbox="786 877 919 940"> </div>



Exposed Ground above 8' to the Communication Level

General Guidance: If there are communication facilities on the pole, exposed grounds above 8 feet to the communication level must be covered. Cover the ground as minor work if possible. If not, create an EC Notification.

Gaps in between molding segments should be covered if, in the inspector's judgment, they are large enough to allow human contact.

If ground is exposed above communication level, **no action required**.

If the pole is not a joint pole, **no action required**, because there is no exposure to the communication worker.





Minor Work: Yes

EC Notification: Yes

Select the Priority and Due Date based upon compelling abnormal condition that may adversely impact public safety and/or service reliability.

Related Documents: [021904](#), [036229](#)

Examples

EXPOSED GROUND AT COMMUNICATION LEVEL	EXPOSED GROUND DUE TO TWISTED MOLDING
	
<p>At this Location: Exposed ground at communications level. Wood molding broken in climbing space.</p> 	<p>At this Location: Exposed ground in wood molding.</p> 
<p>Perform Minor Work: Yes, if safe to do so</p>	<p>Perform Minor Work: Yes, if safe to do so</p>
<p>Write 3rd Party Notification: No</p>	<p>Write 3rd Party Notification: No</p>
<p>Write EC Notification: Yes, only if unable to perform minor work.</p> <p>FDA= Ground / Exposed / Repair</p> <p>Priority= F Tag At minimum – next inspection cycle; based on field condition and exposure, corrosion, etc.; prioritize as needed (A, B, E, or F)</p>	<p>Write EC Notification: Yes, only if unable to perform minor work.</p> <p>FDA=Ground / Exposed / Repair</p> <p>Priority= F Tag At minimum – next inspection cycle; based on field condition and exposure, corrosion, etc.; prioritize as needed (A, B, E, or F)</p>

Ground Molding Unsecured/Loose

General Guidance: Ensure that the molding is in good condition and secured to the pole.

- Look for unsecured and loose wood ground molding, unglued PVC ground molding joints, molding joints that have come apart exposing the ground wire, etc.
- Gaps in between molding segments should be covered if, in the inspector's judgment, they are large enough to allow human contact.

When making repairs - must meet construction standards.





Minor Work: Yes



EC Notification: Yes

Select the Priority and Due Date based upon compelling abnormal condition that may adversely impact public safety and/or service reliability.

Related Documents: [021904](#)

Examples

MOLDING SECURED	MOLDING SECURED
	
<p>At this Location: Molding adequately secured with staples upon arrival. No action is required.</p> <p>Note: Molding for phone ground installed on vis strips is non-compelling.</p> 	<p>At this Location: Molding adequately secured with straps spacing 36 inches or less upon arrival. No action required.</p> 

WOOD MOLDING ABOVE 8', NOT SECURE EXPOSING GROUND	PVC MOLDING ABOVE 8', NOT SECURE EXPOSING GROUND
	
<p>At this Location: PG&E solely owned pole, Wood molding is not secure allowing human contact.</p> <div data-bbox="207 915 350 984"> </div>	<p>At this Location: At communication level, PVC molding not secure, due to failure of previous repairs, allowing human contact.</p> <div data-bbox="792 905 935 974"> </div>
<p>Perform Minor Work: Yes, if safe to do so</p>	<p>Perform Minor Work: Yes, if safe to do so</p>
<p>Write 3rd Party Notification: No</p>	<p>Write 3rd Party Notification: No</p>
<p>Write EC Notification: No</p>	<p>Write EC Notification: Yes, only if unable to perform minor work.</p> <p>FDA=Ground / Exposed / Repair</p> <p>Priority= F Tag At minimum – next inspection cycle; based on field condition and exposure, corrosion, etc.; prioritize as needed (A, B, E, or F)</p>

Exposed Ground Rod

General Guidance: If the ground rod can be permanently covered as minor work, do so. If not, create EC notification.



Minor Work: Yes

EC Notification: Yes

Select the Priority and Due Date based upon compelling abnormal condition that may adversely impact public safety and/or service reliability.

Related Documents: None

Examples

EXPOSED GROUND ROD	
	<p>At this Location: Exposed ground rod, public exposure.</p> <div style="display: flex; align-items: center; gap: 10px;">   </div> <p>Perform Minor Work: Yes, at minimum make safe</p> <p>Write 3rd Party Notification: No</p> <p>Write EC Notification: Yes</p> <p>FDA=Ground / Exposed / Repair</p> <p>Priority= A Tag, emergency – due to public exposure at ground level, if minor work not done.</p>



Broken Grounds

General Guidance: Inspector identifies a broken ground.

Minor Work: Yes

- Perform minor work if possible and if safe to do so.
- IF not able to perform minor work, THEN create EC notification.

EC Notification: Yes

Consider an emergency priority based on where the ground is exposed (Above / Below 8'), and on the amount of public exposure. Inspector should "make safe" if cannot be addressed as minor work, based on location and exposure to the public.

When there is confusion on a PG&E broken ground, contact the lead or supervisor for clarification.

Select the Priority and Due Date based upon compelling abnormal condition that may adversely impact public safety and/or service reliability.

Related Documents: [TD-2990P-01](#);

Examples

Broken Ground Run	
	<p>At this Location: Pole ground has broken, above 8', on a Common Neutral 1000' ground.</p>
	<p>   </p>
	<p>Perform Minor Work: Yes, if safe to do so, Refer to TD-2990P-01 for repair.</p>
	<p>Write 3rd Party Notification: No</p> <p>Write EC Notification: Yes, if not able to be performed under minor work</p> <p>FDA= Ground / Broken / Damaged / Replace or Repair</p> <p>Priority= B Tag, depending on exposure</p>

Broken Ground Run



At this Location: Transformer ground has broken, below 8', in the sidewalk, exposed to the public.

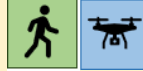

Perform Minor Work: Yes, if safe to do so, Refer to [TD-2990P-01](#) for repair.

Write 3rd Party Notification: No

Write EC Notification: Yes, if not able to be performed under minor work

FDA= Ground / Broken / Damaged / Replace or Repair

Priority= Due to public exposure, A Tag, Follow the emergency procedure If there is low to no public exposure, may use X priority.

Markings

High Voltage Sign Not Installed as Required

General Guidance: Inspectors are required to look for missing or broken high voltage signs during inspections. If inspectors find missing or broken signs, they should install new signs as minor work if they have the appropriate materials and equipment and can perform the work safely. If the inspector cannot install a sign as minor work, the inspector must create a Priority 'F' EC notification. Below is guidance on how to evaluate high voltage signage.

Minor Work: Yes

EC Notification: Yes, if cannot be completed as minor work.

Select the Priority and Due Date based upon compelling abnormal condition that may adversely impact public safety and/or service reliability.

Related Documents: [022168](#)

High Voltage Sign Requirements:

Poles that support line conductors or risers energized at **more than 750 volts** must be marked with high voltage signs.

IMPORTANT: If a pole is marked under **any of the options below**, it satisfies the high voltage marking requirement.

When installing **new** high voltage signs using one option, inspectors are not required to remove signs previously installed under different options.

Marking Options

A. Sign the Pole Below the Lowest 750V+ Line Conductor (**Preferred Method**)

Marking requirements are satisfied under this option if:

- There are two signs, attached to the surface of each side of the pole P¹P.
- The top of each sign is no more than 40" below the lowest level line conductor that exceeds 750V.

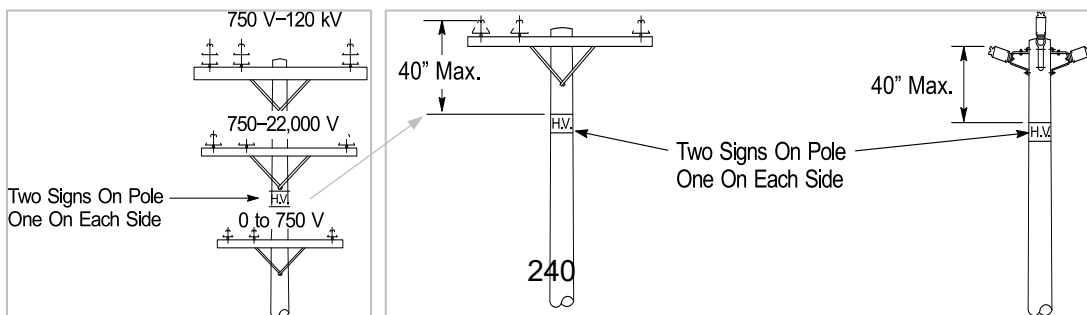

¹**Exception:** If an inspector finds only one high-voltage sign within 40” below the lowest 750V or greater conductor, the inspector is not required to install a second sign. However, when performing work at the lowest crossarm level, a second sign must be installed.

B. Sign the Pole Below Equipment

Marking requirements are satisfied under this option if:

- There are two signs attached to the surface of each side of the pole².
- The top of each sign is no more than 6” below the equipment.
- The signs are above all 0-750V supply and communication line conductors.

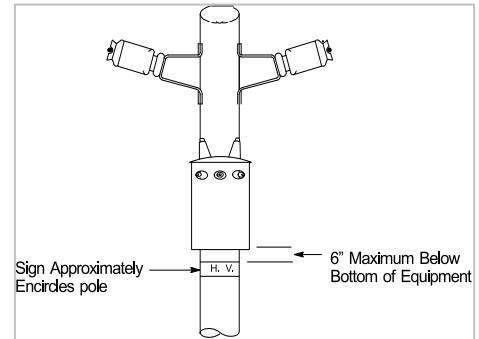

²**Exception:** If an inspector finds only one high-voltage sign installed within 6” below the equipment, the inspector is not required to install a second sign. However, when performing work at the equipment level, a second sign must be installed.

C. Sign Each Crossarm

Marking requirements are satisfied under this option if each crossarm (line arm) supporting line conductors in excess of 750V are signed both front and back. Signs are not required on the inside faces of double arms.

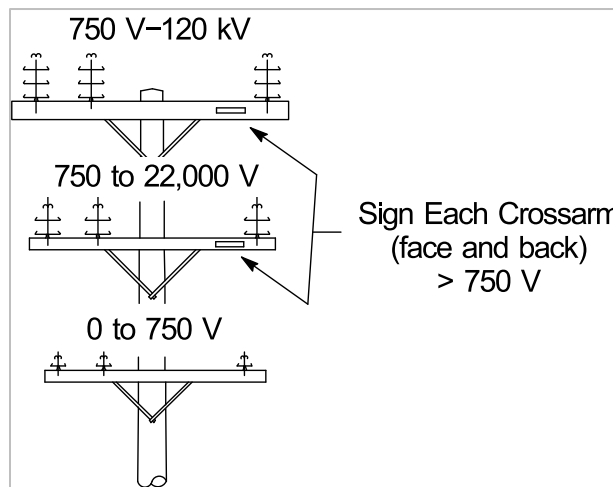









The exceptions in Sections A and B do not apply when, in the judgment of the inspector, the two high voltage signs should be installed so that they may be visible from all sides of the pole.

Typical examples are poles near water areas suitable for sailboats, near established boat ramps and associated rigging areas, adjacent to swimming pools, and in agricultural areas with moveable irrigation piping.

Examples

BROKEN / MISSING HIGH SIGN	
 <p>Broken high voltage sign</p>	 <p>Broken high voltage sign</p>
 <p>High sign installed backwards/upside down</p>	 <p>High sign hanging off of pole</p>
<p>At this Location: Broken / Missing High Sign</p> <p>   </p>	
<p>Perform Minor Work: Yes</p>	
<p>Write 3rd Party Notification: No</p>	
<p>Write EC Notification: Yes, only if minor work cannot be performed.</p> <p>FDA= High Sign / Missing / Install</p> <p>FDA= High Sign / Broken / Damaged / Replace</p> <p>Priority= F Tag, 5 years</p>	



Operating Number Incorrect / Illegible / Missing

General Guidance:

IF the operating number on the field equipment does **not** match the operating number printed on inspection map:

THEN **contact the local Distribution Operation (DO)** to confirm the discrepancy and to get further instructions.

- I. Equipment has a number, does not match GIS mapping records.
 - A. DO confirms the field equipment number is **correct**; then complete a **map correction**.
 - Field employee confirmed with DO the field equipment number is correct.
 - Mapping corrects number in GIS.
 - B. DO confirms the field equipment number is **not correct**; then **perform minor work to correct the operating numbers** on the field equipment.
 - Field employee has the ability to perform the minor work.
 - If minor work cannot be performed, create EC to install correct operating number.
 - FDA = Operating Number / Broken / Replace
 - or
 - FDA = Operating Number / Missing / Install
 - Priority “E” 12 months
- II. Equipment does not have a number.
 - A. DO **cannot confirm the operating number**.
 - Get a PIN from DO
 - Create EC Notification to get an operating number assigned.
 - FDA = Operating Number / Missing / Install
 - Priority “E” 12 months

(Estimating will assign number, crew to complete, and mapping to update GIS)
 - B. DO **confirms** the operating number for the field equipment then:
 - **complete minor work to install the equipment number.**
OR if unsafe to complete
 - Create EC notification for M&C to install number.
 - FDA = Operating Number / Missing / Install
 - Priority “E” 12 months



- Create a RW for a mapping change, for either minor work or EC.
- Inspector or crew will install operating number in the field, mapping will update GIS.

Notes:

- Alpha characters may differ between divisions. Be sure to confirm the "number" with the local DO.
- Operating number should be installed in the operating position; if missing, they should be installed on the operating position, not at the 6' level. Consider also adding the # at the 6' level for ease of identification for field EE's.
- If operating number exists, is it legible (faded, etc.); if not legible replace them as minor work or create an EC notification.
- If operating number is not installed in the field, but on the inspection map - call the DO to confirm the correct number before installing.
- If confirmed that the field is wrong, correct as minor work or create an EC to have corrected.
- If confirmed that the operating number is mapped but not installed in the field, install the operating number as minor work.
- If operating number is not installed in the field, but on the inspection map and/or in GIS - call the team lead who will contact the DO to confirm the correct number before installing.
- If confirmed that the number is mapped but not installed in the field, or the field is incorrect, correct as minor work if possible, or write EC notification.
- Please include detailed comments on what is needed at location.

Minor Work: Yes

Map Correction: Yes, if operating number needs to be corrected.





EC Notification Yes, if you cannot perform minor work.

Select the Priority and Due Date based upon compelling abnormal condition that may adversely impact public safety and/or service reliability.

Related Documents: [057352](#)



Example

FADED OPERATING NUMBER		
Before: Faded operating number	Close Up	After: Minor work completed, operating number applied below operating position.
		
<p>At this Location: Operating number is faded.</p>  		
<p>Perform Minor Work: Yes</p>		
<p>Write 3rd Party Notification: No</p>		
<p>Write EC Notification: Yes, only if minor work cannot be performed. FDA= Marking / Broken / Damaged / Replace Priority= E Tag, 12 months</p>		



Damaged or Missing Visibility Strips on Poles / Guy Markers

General Guidance: Reflective visibility strips shall be installed on wood, fiberglass, or steel poles, streetlight poles, and guy markers as follows:

- A. On poles and guy markers installed on state highways.
- B. On poles and guy markers located within 15 feet from the paved surface or 15 feet from the edge of the traveled, unpaved portion of city or county roads (streets) where not protected by curbs.
- C. On poles and guy markers within 6 feet of an adjacent driveway, private roadway (street), turnaround, parking lot, or thoroughfare in rural district, capable of being traversed by vehicles, where these are not protected by curbs.

Notes:

Visibility strips are not required on poles or guy markers behind a curb, approximately 5-1/2" x 5-1/2" and 90 degrees to the surface.

Visibility strips should not be installed if there is no reasonable expectation of traffic. For example: Cross country poles, poles through waterways or wetlands, rear easements poles, poles behind guardrails, or poles on embankments that are well above or below the road.

Reminders:

- Do not install visibility strips on top of the old one. Inspectors must remove the old strip first.
- If the old strip is in good condition, but became loose, re-secure the strip to the structure.
- Do not install metal visibility strips over any vertical molding/riser.
- If any visibility strip work is required, bring the location up to the current visibility strip standard (all must be the same color – yellow)
- Install visibility strips on the side facing oncoming traffic when known.
- Do not install metal visibility strips within 1-1/2" of hardware that is grounded or may become energized.
- Visibility strips cannot be installed over wood molding, including third party installations.
- If existing visibility strips become damaged or otherwise do not serve their intended purpose, they shall be replaced.
- If unable to install at time of inspection due to lack of material, create EC notification.







Minor Work: Yes



EC Notification: Yes, if cannot be completed as minor work.



Select the Priority and Due Date based upon compelling abnormal condition that may adversely impact public safety and/or service reliability.



Related Documents: [022168](#), GO 95 Rule 56.9 (1964, 1990, 1996 Change to Guy Marker)

Examples





ACCEPTABLE	
ADHESIVE VISIBILITY STRIPS	CLEARANCE FROM GROUND
	
<p>At this Location: Acceptable application of plastic and adhesive visibility strips.</p> <p>Note: Molding for phone ground installed on vis strips is non-compelling.</p> <div style="display: flex; gap: 5px;">   </div>	<p>At this Location: Acceptable metal visibility strips attached 1 ½ "from ground.</p> <div style="display: flex; gap: 5px;">   </div>

INADEQUATE VISIBILITY STRIPS	
	<p>At this Location: Pole with vehicular exposure. Two small sections of yellow adhesive visibility strips.</p> <div style="display: flex; justify-content: space-around;">   </div>
	<p>Perform Minor Work: Yes</p> <p>apply 3 adhesive visibility strips on the pipe. apply 3 adhesive visibility strips to the plastic molding.</p>
	<p>Write 3rd Party Notification: No</p>
	<p>Write EC Notification: Yes, if minor work cannot be performed.</p> <p>FDA= Vis-Strips / Broken / Damaged / Replace</p> <p>Priority= At minimum –must write up as Priority F Tag next inspection cycle; based on field condition and exposure, corrosion, etc.; prioritize as needed (A, B, E, or F)</p>

VISIBILITY STRIPS PAINTED OVER NO LONGER REFLECTIVE	
	<p>At this Location: Visibility strips painted brown (3PrdP visibility strip located above not shown in picture).</p> <div style="display: flex; justify-content: space-around;">   </div>
	<p>Perform Minor Work: Yes</p> <p>Remove old visibility strips and install new</p>
	<p>Write 3rd Party Notification: No</p>
	<p>Write EC Notification: Yes, if minor work cannot be performed.</p> <p>FDA= Vis-Strips / Broken / Damaged / Replace</p> <p>Priority= At minimum – must write up as Priority F Tag next inspection cycle; based on field condition and exposure, corrosion, etc.; prioritize as needed (A, B, E, or F)</p>

METAL OVER MOLDING	
Before	After
	
<p>At this Location: Metal visibility strips under wood molding and over wood molding with protruding edge.</p> <div style="display: flex; align-items: center;"> </div>	
<p>Perform Minor Work: Yes, remove old metal visibility strips and apply new visibility strips; visibility strips installed in “after” photo are fiber, not metal (coded item)</p>	
<p>Write 3rd Party Notification: No</p>	
<p>Write EC Notification: Yes, only if minor work cannot be performed. FDA= Vis-Strips / Broken / Damaged / Replace</p>	
<p>Priority= At minimum – must write up as Priority F Tag next inspection cycle; based on field condition and exposure, corrosion, etc.; prioritize as needed (A, B, E, or F)</p>	



<p>OLD METHOD VISIBILITY STRIPS NOT YELLOW</p>	<p>OLD AND NEW VISIBILITY STRIPS NOT YELLOW</p>
	
<p>At this Location: Aged visibility strips have lost reflectivity.</p> 	<p>At this Location: Yellow visibility strips mounted over old white visibility strips.</p> 
<p>Perform Minor Work: Yes, Replace with 3 yellow visibility strips</p>	<p>Perform Minor Work: Yes, remove old visibility strips</p>
<p>Write 3rd Party Notification: No</p>	<p>Write 3rd Party Notification: No</p>
<p>Write EC Notification: Yes, if minor work cannot be performed. FDA= Vis-Strips / Broken / Damaged / Replace</p> <p>Priority= At minimum – must write up as Priority F Tag next inspection cycle; based on field condition and exposure, corrosion, etc.; prioritize as needed (A, B, E, or F)</p>	<p>Write EC Notification: Yes, if minor work cannot be performed. FDA= Vis-Strips / Broken / Damaged / Replace</p> <p>Priority= At minimum – must write up as Priority F Tag next inspection cycle; based on field condition and exposure, corrosion, etc.; prioritize as needed (A, B, E, or F)</p>

GRAFFATI ON VISIBILITY STRIPS	
	<p>At this Location: Visibility strips have spray paint.</p> <div style="display: flex; align-items: center; gap: 10px;">   </div>
	<p>Perform Minor Work: Yes, replace vis strips.</p>
	<p>Write 3rd Party Notification: Yes</p>
	<p>Write EC Notification: Yes, if cannot complete minor work.</p> <p>FDA= Visibility Stripe / Broken / Damaged / Replace</p> <p>Priority= Priority F Tag</p> <p>Note: Molding for phone ground installed vis strips alone is non-compelling.</p>



Streetlights

Broken or Damaged Streetlight Pole



General Guidance: While streetlights aren't part of an inspection list, if one is seen with a compelling abnormal condition, then create EC notification.

Minor Work: No

EC Notification: Yes

Related Documents: TD-2309S, [TD-2307M](#)

Example

MISSING STREET LIGHT	LEANING AGGREGATE POLE
	
<p>At this Location: Cone indicates location of missing decorative streetlight and pole. Exposed wire is de-energized.</p> <div data-bbox="105 982 251 1052"> </div>	<p>At this Location: Leaning aggregate pole more than 10% out of plumb. Pole is broken at base and not stable. Light still working.</p> <div data-bbox="824 968 971 1037"> </div>
<p>Perform Minor Work: Yes, make safe</p>	<p>Perform Minor Work: No</p>
<p>Write 3rd Party Notification: No</p>	<p>Write 3rd Party Notification: No</p>
<p>Write EC Notification: Yes, only if minor work cannot be performed. FDA= Decorative Streetlight / Broken/Damaged / Replace Priority= E Tag, add in field comment section – describe if pole is missing.</p>	<p>Write EC Notification: Yes FDA= Pole / Broken/Damaged / Replace Priority= B Tag, depending on exposure</p>



Day Burner

General Guidance: **Do not** create an EC Notification for a day burner. Call Restoration Dispatch or PBX hotline internal non-emergency 1-415-973-7000 to get a T-Man to respond. This is to ensure correct accounting for streetlight work (depending on the rate that the customer is one, etc.).

Minor Work: Yes, if you have the materials on your truck.

EC Notification: No

Related Documents: Utility S2309

Missing Streetlight Head

General Guidance: If the inspector notices that a missing streetlight, first, make safe then create EC notification to install a missing streetlight.

Minor Work: No

EC Notification: Yes

Related Documents: Utility S2309



Wildlife Protection

Existing Migratory Bird Protection Damaged

General Guidance: Evaluate locations where bird protection has previously been installed to assess if it is adequate or is missing or broken. If not adequate or needs repair, create EC notification to repair or install.

When in doubt reach out to Supervisor / Lead to reach out to avian specialist.

Note: If there is a nest at the location, write EC Notification to install bird protection if nest is already abandoned.

Minor Work: No

Related Documents: [Utility S2321](#), [061149](#)

Reference: [066209 – Repair of Damaged Pole Tops](#)

Per [066209](#):

Active Nests:

- Active Nests are ones with eggs or young in them.
- Do not disturb active nests unless they present an immediate safety or operating hazard.

Contact Lead / Supervisor or the avian program management personnel or the Bird Hotline at (415) 973-9453 for assistance with an active nest removal or relocation.



Inactive Nests:

- Inactive nests are those nests without viable eggs or young.
- Inactive nests, except eagle nests or T&E (threatened and endangered) species' nests, can be removed; however, do not keep an inactive nest without notifying avian program management personnel or governmental agencies. Nests may be difficult to identify.

If there is any uncertainty about the type of nest, contact Lead / Supervisor or the avian program management personnel or the Bird Hotline at (415) 973-9453 for assistance with an active nest removal or relocation.

Examples

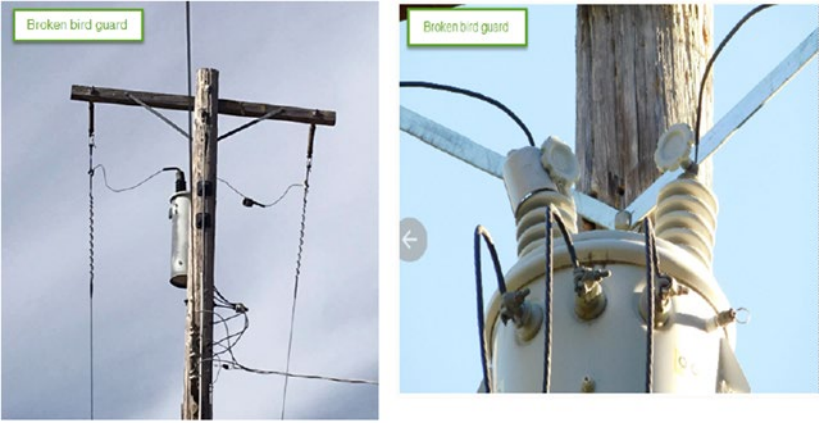
BIRD NEST ON TRANSFORMER	
	<p>At this Location: Bird Nest on transformer, abandoned, touching high side jumper.</p> <p> </p>
	<p>Perform Minor Work: No</p>
	<p>Write 3rd Party Notification: No</p>
	<p>Write EC Notification: Yes</p> <p>FDA= Overhead facility / Bird Nest / Remove</p> <p>FDA= Bird protection / Bird protection Deteriorated / Install</p> <p>Priority= X Tag</p>

BROKEN INSULATOR COVERS	
	<p>At this Location: Broken insulator covers.</p> <p> </p>
	<p>Perform Minor Work: No</p>
	<p>Write 3rd Party Notification: No</p>
	<p>Write EC Notification: Yes</p> <p>FDA= Broken / Damaged / Replace / Mitigation Missing Install/ Bird Protection Replace / Bird Protection install / Bird Protection Deteriorated Replace/ Bird Protection Deteriorated install. Whichever FDA is applicable.</p> <p>Priority= E Tag, 3-12 months depending on exposure</p>

Exiting Wildlife Protection Damaged

General Guidance: Inspector should create EC notification to replace damaged or missing existing wildlife protection installed in the field (e.g., Cattle Guard, Squirrel Guard).

Minor Work: No

EC Notification: Yes

FDA: Animal Mitigation / Broken / Damaged / Replace

Related Documents: [061149](#)

Note: For these kinds of conditions, use

Examples

Bird protection

Center phase cover installed on conductor.





Riser Molding

Broken/Missing Riser Ground

General Guidance: See 'Ground / Ground Molding in this job Aid.

Minor Work: None

Related Documents: [027742](#)

U-Shape Riser Molding Broken/Damaged or Unsecured

General Guidance – Existing Molding:

Ensure bottom section of ground molding is flush against the pole.

IF molding is NOT firmly attached to pole

THEN Perform Minor Work to secure molding to pole by attaching all lags **OR** Create EC Notification

Address any gaps identified via minor work or create an EC notification.

General Guidance if Installing New Molding or Repairing Existing Molding:

- **Below 8 feet:** Both sides of the molding must be secured to the pole at least every 18 inches (a lag in every hole).
- **Above 8 feet:** Both sides of the molding must be secured to the pole at least every 36 inches.

Minor Work: Yes

EC Notification: Yes

Related Documents: [021924](#)

Example

CRACKED RISER BOOT	BROKEN RISER
	
<p>At this Location: Cracked riser boot</p> 	<p>At this Location: Broken riser</p> 
<p>Perform Minor Work: Yes, if possible</p>	<p>Perform Minor Work: Yes, if possible</p>
<p>Write 3rd Party Notification: No</p>	<p>Write 3rd Party Notification: No</p>
<p>Write EC Notification: Yes, only if minor work cannot be performed. FDA= Molding / Broken / Damaged Priority= F Tag, depending on exposure</p>	<p>Write EC Notification: Yes, only if minor work cannot be performed. FDA= Molding / Broken / Damaged / Replace Priority= A Tag, follow emergency process</p>



Pole Steps

General Guidance: Remove any pole steps less than 8 feet 6 inches above the ground or any other accessible surface; this allows for grading, landscaping, etc.

Minor Work: Yes

EC Notification: Yes, if above 7.5 feet and cannot be completed as minor work.

3rd Party Notification: Yes, if below 7.5 feet.

Select the Priority and Due Date based upon compelling abnormal condition that may adversely impact public safety and/or service reliability.

Related Documents: [022616](#) page 2, section 5 [027911](#)

Declaration Items

Trees

Trees within 4 Feet of a Primary Line

General Guidance: If you have any questions about the integrity of tree that could impact electric facilities, (causing damage to our facilities, dead or dying, causing conductor height issue, could fall into line etc.), write a Vegetation Notification to remove dead/dying tree.

Broken Limb on Conductor that has potential to cross-phase or has strain:
Remove the limb as minor work with a hot stick if it is safe to do so. If minor work cannot be completed, and has potential to cross phase or strain, then create EC Notification X tag.

Vegetation Touching Bare Primary Conductor or Signs of Burning or Arcing:
Create an emergency Priority "A" Vegetation Management Tag and call supervisor or lead for assistance in contacting vegetation management. Wait at the location until relieved.

Vegetation Not Touching Bare Conductor and No Signs of Burning or Arcing:
Create a Vegetation Management notification.

Minor Work: Yes

EC Notification: Yes

Related Documents: GO 95 Rule 35

Examples

LARGE BRANCH BROKEN	
	<p>At this Location: Large branch broken on cross-arm. Cross-arm in poor condition. No charring visible.</p>
	<p>Perform Minor Work: No</p>
	<p>Write 3rd Party Notification: No</p>
	<p>Write Vegetation Notification: No</p>
	<p>Write EC Notification: Yes</p> <p>FDA= Cross-arm / broken / damaged / Replace</p> <p>FDA= Tree / clearance / Remove</p> <p>Priority= Minimum X Tag, depending on exposure.</p>



DEAD TREE BRANCH FELL INTO PRIMARY



At this Location: Dead tree branch fell into primary. No charring visible.



Perform Minor Work: No







Write 3rd Party Notification: No

Write Vegetation Notification: No

Write EC Notification: Yes

FDA= Tree / clearance / Remove

Priority= Minimum X Tag, depending on exposure.

SMALL BRANCHES ON PRIMARY AND SECONDARY	LONG TREE BARK HANGING ON PRIMARY CONDUCTOR
	
<p>At this Location: Small branches on primary and secondary. Too small to cause a cross-phase or damage.</p> <p> </p>	<p>At this Location: Long tree bark strands, hanging from bare primary conductor, phase separation on single phase cross-arm far enough not to cause cross-phase.</p> <p> </p>
<p>Perform Minor Work: Yes, if possible</p>	<p>Perform Minor Work: Yes, if possible</p>
<p>Write 3rd Party Notification: No</p>	<p>Write 3rd Party Notification: No</p>
<p>Write EC Notification: No</p>	<p>Write EC Notification: Yes, only when minor work not performed.</p> <p>FDA= Tree / Clearance / Remove</p> <p>Priority= B Tag, depending on exposure</p>



Trees Causing Strain or Abrasion to a Secondary Conductor or Service

General Guidance:

If vegetation is:

- A. Causing damage to the conductor insulation due to friction (Note: scuffing and polishing is NOT damaged) **OR**
- B. Causing strain on the conductor that is moving the conductor outside of normal slack or pushing wires closer together.

Note: The inspector should clear the vegetation or move the conductor as minor work if possible. Inspectors should leave the trimmings at the location; use door hanger to notify customer.

If the inspector cannot clear the vegetation or move the conductor:

- For service drops: Create an EC notification.
- For secondary conductor spans serving 2 or more customers: Write a Vegetation Management notification with priority based on severity.

Note: Vegetation Management considers secondary as conductor that feeds more than one physical address (per Rule 16); i.e., multiple “service” conductors feeding the **same customer/property are considered service**, not secondary; Inspector will need to **create an EC** in this scenario.



If the inspector sees a hazardous vegetation issue on communication facilities, create a third- party notification.



Minor Work: Yes

EC Notification: Yes



Related Documents: GO 95 Rule 35 and Rule 16

Examples

PHONE TREE CONDITION	
	<p>At this Location: Tree putting strain on the pole, due to communication line.</p> <div style="display: flex; gap: 10px;">   </div>
	<p>Perform Minor Work: No</p>
	<p>Write 3rd Party Notification: Yes</p>
	<p>Write EC Notification: No</p>

SECONDARY HARD AGAINST TREE	SECONDARY OVERGROWN REDUCING CONDUCTOR CLEARANCES
	
<p>At this Location: Secondary conductor resting on tree/vegetation. Tree causing strain on open wire secondary, feeding more than one customer.</p>	
	
<p>Perform Minor Work: No</p>	
<p>Write 3rd Party Notification: No</p>	
<p>Write Vegetation Notification: Yes</p>	
<p>FDA= Tree / Strain or Abrasion Secondary / Trim</p>	
<p>Priority= E Tag, depending on exposure</p>	
<p>Write EC Notification: No</p>	



TREE STRAIN ON SERVICE DROP	
	<p>At this Location: Tree strain on service drop.</p> <p>   </p>
	<p>Perform Minor Work: No</p>
	<p>Write 3rd Party Notification: No</p>
	<p>Write Vegetation Notification: No</p>
	<p>Write EC Notification: Yes FDA= Tree / Vine / Overgrown / Trim Priority= E Tag, depending on exposure</p>



Trees Overgrown, NOT Causing Strain or Abrasion to a Secondary Conductor or Service

General Guidance: If trees are in contact with secondary conductor serving multiple customers or a covered service conductor **not** causing strain or abrasion, no EC tag or minor work is necessary.

Minor Work: No

EC Notification: No

Related Documents: GO 95 Rule 35 and Rule 16

Examples

TREE GROWING INTO BARE OPEN WIRE SECONDARY OR BARE OPEN WIRE SERVICE, NO STRAIN OR ABRASION



At this Location: Tree grown around bare open wire secondary, no strain or abrasion. Spreader bracket already installed.



Perform Minor Work: No

Write 3rd Party Notification: No

Write Vegetation Notification: No

Write EC Notification: No



TREE GROWING AROUND SERVICE, NO STRAIN OR ABRASION



At this Location: Tree grown around service, no strain or abrasion.



Perform Minor Work: No

Write 3rd Party Notification: No

Write Vegetation Notification: No

Write EC Notification: No



Idle Facilities

Identifying and Documenting Idle Facilities

- Inspectors identify and document idle lines as they would for any other field condition found, per the requirements and procedures in the Electric Distribution Preventative Maintenance (EDPM) Manual [TD-2305M](#).

Notes:

- 1) Whether a line is idle or not, continue to create EC notifications to document safety, reliability, and/or regulatory issues and create EC notifications for Vegetation Issues.
 - 2) All vegetations issues on idle facilities shall be written up on an EC tag. Do not create Veg only notifications for idle lines. Vegetation management personnel do not patrol or maintain vegetation on de-energized tap lines.
 - Compliance Inspections follow the Idle Facility Program as documented in [TD-2459P-01](#) and use the annual Detailed Overhead Inspection Checklist to indicate when an Idle condition is present for the inspection location by checking the observed an Idle Facility box.
- When an idle condition is selected, the inspector shall select from 4 reasons:
 1. Pole is not mapped idle. It is de-energized.
 - Create IF Notification (using the Inspect App)
 2. Pole is not mapped idle. It is energized.
 - Create IF Notification (using the Inspect App)
 - Create EC Notification (to de-energize)
 3. Pole is mapped idle. It is de-energized.
 - No further action required.
 4. Pole is mapped idle. It is energized.
 - Create EC Notification (to de-energize)
 - **Inspect App:** Use the IF Notification in the Inspect App to document an observed Idle Facility field condition. These include asset information, location information, facility type, field conditions, and comments and photos. Compliance Inspectors will select the appropriate Priority as follows:
 1. High Priority
 - Location is associated with a new or existing EC Notification B Priority for maintenance work at this location.



NOTE: Excludes “Idle Facility/De Energize”

2. Medium Priority

- Transformer Present (Suspect PCB could elevate this to high priority depending on field conditions or exposure)
- HFTD T3/T2
- Oil Filled Equipment
- Modesto Irrigation District (60 days)

3. Low Priority

- All other conditions

This listing is an overall summary of the guidance for IF Priority selection. For more detailed guidance please refer to the table below also included in TD-2459P-01

- At a **minimum**, attach the following three images to each IF Notification:
 - Two field photos of the field condition
 - Screenshot of Map with the idle area clearly identified.

In addition, please include any other photos that may be useful to the investigation e.g., photo of the meter or a panel with no meter.

Notes:

- 1) Continue to document safety, reliability, and/or regulatory issues for EC and Vegetation Notifications. Vegetation management personnel **do not** patrol or maintain vegetation on de-energized tap lines.
- 2) Use Table 1 from [TD-2459P-01](#) to help in understanding the various priorities.
- 3) Mapping resources are an additional tool help to identify idle facilities but should **NOT** be solely relied on to create EC Notifications to de-energize. Be sure to field confirm.



Idle Facility Program

Table 1. Idle Facility Field Conditions and Investigation Priorities

Condition	Action	Investigation Priority
Safety situation/risk.	<ul style="list-style-type: none"> Mitigate hazard and make safe, which may include de-energizing. Initiate an IF notification for investigation. Initiate an electric corrective (EC) notification to document any other abnormal conditions to resolve. Initiate a Priority B, 3-month EC notification to de-energize the facility. 	<ul style="list-style-type: none"> High Submit to supervisor by end of day. Enter in SAP and communicate to idle facility investigation personnel within two business days.
<p>Idle transformers that do not have a blue sticker indicating a polychlorinated biphenyl (PCB) content of less than 5 parts per million (ppm) may be classified as high, medium, or low priority.</p> <p>Consider current field conditions¹, the transformer condition, and if the following sensitive locations are nearby:</p> <ul style="list-style-type: none"> Surface or ground waters Sewers or sewage treatment systems Private or public drinking water sources or distribution systems Grazing lands Vegetable gardens or agricultural areas Daycare centers and schools 	<p>If high priority, then mitigate hazard and make safe, which may include de-energizing.</p> <ul style="list-style-type: none"> Initiate an IF notification for investigation; priority is dependent on field and equipment conditions. Note the specific field conditions, transformer condition, and transform locations (see "Condition" column notes) in the Comments section Initiate a Priority B, 3-month EC notification to de-energize the facility 	<ul style="list-style-type: none"> High – Medium – Low To designate as high priority, consider the identified idle transformer locations, current condition of the transformer (see "Condition" column notes), and current condition of associated facilities (pole, crossarm, etc.)
Future work required to maintain existing idle facility (EC notifications to repair/replace/relocate facilities).	<ul style="list-style-type: none"> Initiate an IF notification for investigation and ensure the Future Work Requested field is checked Initiate a Priority B, 3-month EC notification to de-energize the facility 	High – Medium – Low
PG&E and Modesto Irrigation District (MID) service areas.	<ul style="list-style-type: none"> Initiate an IF notification for investigation Initiate a Priority B, 3-month EC notification to de-energize the facility 	Medium
<p>Idle facilities in raptor concentration zones (RCZs) with suitable habitat to support threatened or endangered raptors.</p> <p>Oil-filled equipment considerations:</p> <ul style="list-style-type: none"> Surface or ground waters Sewers or sewage treatment systems Private or public drinking water sources or distribution systems Grazing lands Vegetable gardens or agricultural areas Daycare centers and schools 	<ul style="list-style-type: none"> Initiate an IF notification for investigation. Initiate a Priority B, 3-month EC notification to de-energize the facility. Initiate an IF notification for investigation. For idle transformers, note the absence or presence of a blue sticker on the IF notification; a blue sticker indicates a PCB content of less than 5 ppm Initiate a Priority B, 3-month EC notification to de-energize the facility. 	<p>Medium – Low</p> <p>Medium</p>
Idle facility in Tier 2 & 3 fire zone.	<ul style="list-style-type: none"> Initiate an IF notification for investigation. Initiate a Priority B, 3-month EC notification to de-energize the facility. 	Medium
Potential use for agricultural pumps or vacant buildings.	<ul style="list-style-type: none"> Initiate an IF notification for investigation. Initiate a Priority B, 3-month EC notification to de-energize the facility 	Low
Entire primary tap is identified as idle and is unused. No future work is required to maintain the existing idle facility.	<ul style="list-style-type: none"> Initiate an IF notification for investigation. Initiate a Priority B, 3-month EC notification to de-energize the line. 	Low



- 4) **You may find coding already annotated on the maps when inspecting idle lines.** Use Table 2 to help in understand the mapping annotations.

Note: When using the Inspect App, ensure that “feature note” is enabled to see

Table 2. TOS/TIF Classifications

Temporary Out of Service (TOS) De-Energized Temporary Idle Facility (TIF) Energized		
Facilities with a future use are grouped into one of the following classifications:		
TOS-AG	Potential agricultural use	De-energized
TIF-AG	Potential agricultural use	Energized
TOS-V	Potential service to an existing vacant building	De-energized
TIF-V	Potential service to an existing vacant building	Energized
TOS-CAP	Potential PG&E use for capacity or reliability	De-energized
TIF-CAP	Potential PG&E use for capacity or reliability	Energized
TOS-F	Future customer use identified by service planning	De-energized
TIF-F	Future customer use identified by service planning	Energized
TOS-MLX	Current Main Line Extension Agreement	De-energized
TIF-MLX	Current Main Line Extension Agreement	Energized
TOS-SFA	Current Special Facilities Agreement	De-energized
TIF-SFA	Current Special Facilities Agreement	Energized

annotations on maps.

- 5) When new maintenance is identified on energized idle facilities, write **THREE** notifications:
- One IF Notification ([TD-2459S-F01](#)) for the entire idle line
 - One EC Notification to de-energize the entire idle line.
 - One EC Notification per location requiring maintenance or veg work.
- 6) After identifying pending maintenance on idle facilities, ensure that the IF Notification has the Field Condition box “Future work required to maintain existing idle facility” checked.
- Enter the following note in the EC Notification comments section: “IDLE notification created.”
 - Enter a note in both IF Notification and EC Notification comments with corresponding notification numbers, when available.
- 7) Always ask your PG&E Lead, IRS, or Supervisor for help in determining priority, creating the IF Notification, and creating an EC Notification to de-energize the idle line.



Energized Electric Line Facility No Longer Used to Serve Customer Load

General Guidance: It may be necessary to de-energize the idle facility:

- If primary lines are energized, de-energize line sections by opening cut-outs when possible and safe to do so. If you are unable to safely de-energize OR you are in raptor concentration zones (RCZs) OR if the primary tap line is unfused, create a Priority B, 3-month Electric Corrective (EC) Notification to de-energize the facilities (AND de-energize jumpers if in RCZ).

NOTE:

When idle transformers or sections of the line de-energized by cut-outs, are located in non-raptor areas, an EC Notification is **NOT REQUIRED** to de-energize the jumpers.

Do not initiate an IF Notification or an EC Notification when attachments to poles (cross-arms, miscellaneous hardware, brackets, insulators, etc.) do not pose a safety or reliability risk to an idle facility. If it is not necessary to de-energize the idle facility, create a Priority “F” EC Notification.

Continue to document safety or reliability issues that meet criteria for vegetation notifications.

Minor Work: No

EC Notification: Yes, to de-energize.

Idle Facility Form: Yes

Related Documents: [TD-2459P-01](#)



De-Energized Electric Line Facility Already Identified on a Pending EC Notification but Not Mapped

General Guidance: Create a map change request if the facility is not mapped as idle. Also, if a facility is mapped as idle but serves customer load, create a map change.

Note: Do not de-energize active customers.

Minor Work: No

Map Correction: Yes

Related Documents: [TD-2459P-01](#)

Idle Hardware

General Guidance:

When a field employee encounters extra unused hardware on a pole (cross-arms, miscellaneous hardware, brackets, insulators, etc.), if hardware poses no safety or reliability issue, then no action required.

If hardware poses or could pose safety or reliability issue create an EC Tag. Do not write up IF notification solely due to "idle hardware."

Minor Work: Yes, if safe to remove.

EC Notification: Yes, if cannot complete minor work.

Select the Priority and Due date based upon compelling abnormal condition that may adversely impact public safety and/or service reliability.

Abandoned Pole Butt

General Guidance: If there is any compelling safety related issue regarding an abandoned pole butt, not just the existence of an abandoned pole butt, write EC notification.

Minor Work: No



EC Notification: Yes



Select the Priority and Due Date based upon compelling abnormal condition that may adversely impact public safety and/or service reliability.



Example

ABANDONED POLE BUTT	
	<p>At this Location: Abandoned Pole Butt, low risk</p> <div style="display: flex; justify-content: space-around;"> <div style="background-color: #c8e6c9; padding: 5px;"></div> <div style="background-color: #bbdefb; padding: 5px;"></div> </div>
	<p>Perform Minor Work: No</p>
	<p>Write 3rd Party Notification: No</p>
	<p>Write EC Notification: No</p>

ABANDONED POLE BUTT – HOLLOWED OUT BELOW GROUND LEVEL	
	<p>At this Location: Abandoned Pole Butt with a safety issue such as a tripping hazard, hollowed out below ground level.</p> <p> </p>
	<p>Perform Minor Work: No</p>
	<p>Write 3rd Party Notification: No</p>
	<p>Write EC Notification: Yes FDA= Relinquished Pole / Decayed / Rotten / Remove</p> <p>Priority= E Tag, depending on exposure</p>

RELINQUISHED POLE	
	<p>At this Location: Relinquished Pole, no compelling abnormal conditions</p> <p> </p>
	<p>Perform Minor Work: No</p>
	<p>Write 3rd Party Notification: No</p>
	<p>Write EC Notification: No</p>



3rd Party Notification

Utility – Cable, Phone, and other Electric Utility Partners

General Guidance: If safety or reliability issues are encountered with joint utility or tenant facilities on structures, create a 3rd party utility notification. For emergencies contact your supervisor or Lead.

Inspectors should specifically look for the items in the referenced standard.

- 1) Safety Hazards (Strict definition of Level 1 conditions)
- 2) Third party issues that impact PG&E facilities.

We should not write TPs with lower priority items; this is not the intent. For example, by this definition, slack TP guys would not hit the threshold unless they impact PG&E facilities.

Comcast Dispatch - 1-888-824-8219 (for level 1 priorities)

AT&T Emergency Dispatch: 1-888-978-3889 (level 1 priorities)

Note: When filling out form, choose either phone or cable. Only choose “unknown,” if unsure whether phone or cable.

Minor Work: No

EC Notification: No

3rd Party Utility Notification: Yes

References: [TD-2014P-01](#)



Example

COMMUNICATION LINE EXTREMELY SAGGED	
	<p>At this Location: Comm sag 6' above the road, off the road, no potential for vehicle contact.</p>
	<p>   </p>
	<p>Perform Minor Work: No</p>
	<p>Write 3rd Party Utility Notification: Yes</p> <p>Priority: Level 2</p>
<p>Write EC Notification: No</p>	



3rd PARTY CABLE LOOSE LASHING LONG ENOUGH TO WHIP INTO POWER LINES

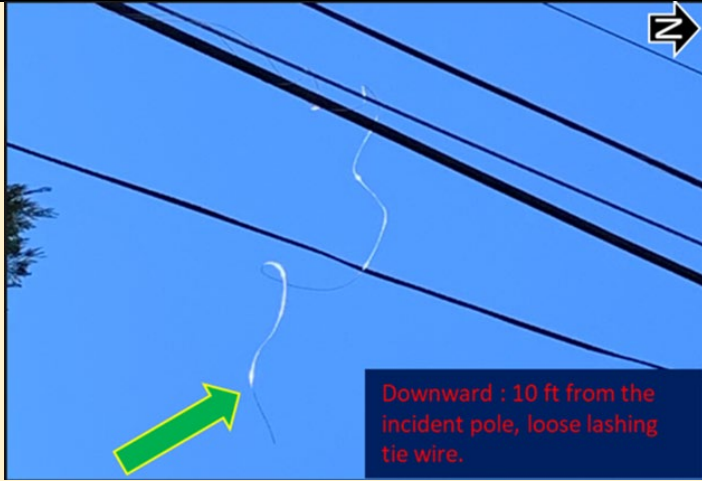

Before



After - Snip Lashing and Tape

At this Location: 3rd party communication line has a loose lashing long enough to whip into power lines. Stand-by situation.



Perform Minor Work: Yes, if safe to do so

Write 3rd Party Notification: Yes

Priority= Level 1

Write EC Notification: Yes, if minor work cannot be completed.

FDA= Conductor / Loose Lashing / Repair

Priority= Minimum X Tag, depending on exposure.

*Contact Lead/Supervisor for guidance



ABONDONED PHONE DROP

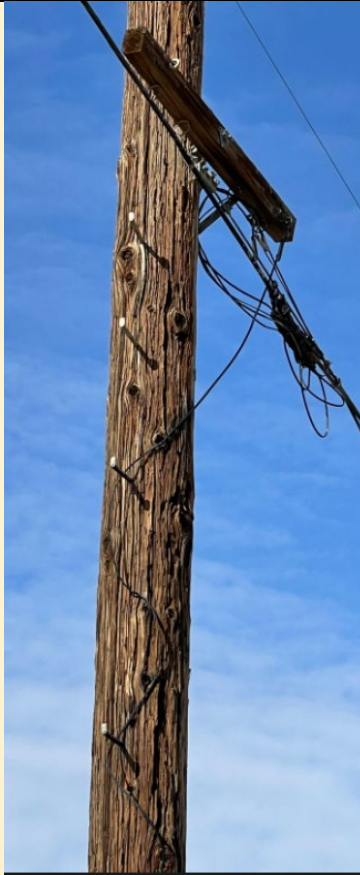

At this Location: Abandoned Phone Drop with potential of public safety exposure.



Perform Minor Work: No

Write 3rd Party Notification: Yes

Priority= Level 3

Write EC Notification: No



Antennas - Third Party Communication

A. Broken/Damaged Cellular Antenna

General Guidance: If the broken antenna is creating a non-emergency safety or reliability issue, create a third-party notification.

If the antenna is causing an emergency safety or reliability issue, contact your supervisor for instructions. Do not leave the location until it is made safe.

Minor Work: No

EC Notification: No

Third Party Notification: Yes

Related Documents: [027911](#)

B. Third Party Communication Antenna - Inadequate Clearance

General Guidance: Create a third-party notification if a cellular antenna does not have adequate clearance from supply lines or equipment.

If the antenna is causing an emergency safety or reliability issue, contact your supervisor for instructions. Do not leave the location until it is made safe.

Minor Work: No

EC Notification: No

Third Party Notification: Yes

Related Documents:

C. Broken/Damaged Cellular Antenna

General Guidance: If the broken antenna is creating a non-emergency safety or reliability issue, create a third-party notification.

If the antenna is causing an emergency safety or reliability issue, contact your supervisor for instructions. Do not leave the location until it is made safe.

Minor Work: No

EC Notification: No

Third Party Notification: Yes

Related Documents: [027911](#)



D. Third Party Communication Antenna - Inadequate Clearance

General Guidance: Create a third-party notification if a cellular antenna does not have adequate clearance from supply lines or equipment.

If the antenna is causing an emergency safety or reliability issue, contact your supervisor for instructions. Do not leave the location until it is made safe.

Minor Work: No

EC Notification: No

Third Party Notification: Yes

Related Documents: [027911](#)

Non - Utility

General Guidance: Unauthorized attachment installed on a PG&E pole such as a mailbox, basketball hoops, etc. Prioritize based on risk and exposure.

Note: If the unauthorized attachment causes electrical hazard, or immediate risk to the pole, assign Level 1 priority and contact Supervisor.

Minor Work: Yes, as long as it can be done safely and doesn't create a safety hazard, **DO NOT** remove mirrors on windy roads/driveways, street/stop signs, camera equipment, etc.

EC Notification: No

3rd Party Non-Utility Notification: Yes, comments need to be created and will be attached to the letter to the customer / homeowner.



Example

UNAUTHORIZED ATTACHMENT	
	<p>At this Location: Basketball Hoop Installed on a PG&E pole.</p>
	<p>Perform Minor Work: No</p>
	<p>Write 3rd Party Notification: Yes, Level 3 priority.</p>
	<p>Write EC Notification: No</p>

METAL POLE IN FENCE	
	<p>At this Location: Metal attachment on metal structure. Fence can become energized.</p>
	<p>Perform Minor Work: Work with Supervisor to resolve immediate hazard.</p>
	<p>Write 3rd Party Notification: Yes, Level 1 priority.</p>
	<p>Write EC Notification: No</p>



FDA - Distribution OH Facility Damage Action Table

Table 1

Overhead Facility	Damage	Action	Default Priority
Anchor	Broken/Damaged	Repair	E
		Replace	E
	Corroded	Repair	E
		Replace	E
	Missing	Install	F
	Soil/Eroded/Graded	Adjust	F
Replace		F	
Animal Mitigation	Broken/Damaged	Replace	E
	Mitigation Missing	Install	E
Bird Protection	Bird Protection Deteriorated	Replace	E
		Install	E
Bonding	Broken	Repair	E
	Broken	Replace	E
Booster/Regulator	Broken/Damaged	Repair	E
		Replace	E
	Burnt	Repair	E
	Excessive Operation	Overhaul	E
	Leaks/Seeps/Weeps	Clean	E
		Repair	E
Replace		E	
Buddy Pole	Improperly Supported	Repair	E
Capacitor	Broken/Damaged	Repair	E
		Replace	E
	Burnt	Repair	E
		Replace	E
	Leaks/Seeps/Weeps	Clean	B
		Repair	E
Replace		E	
CB Pole	Broken/Damaged	Replace	F
	Burnt	Replace	E
	Decayed/Rotten	Replace	F
Climbing Space	Obstructed	Adjust	F
Conductor	Broken/Damaged	Repair	E
		Replace	E



**Job Aid:
Overhead Assessment**

	Burnt	Repair	E
		Replace	E
	Clearance Impaired	Adjust	E
		Install CI Pole	E
		RayChem	E
	Floater	Repair	E
	Idle Facility	Remove	E
	Improper Connection	Adjust	E
	Overloaded	Test	E
	Sag/Clearance	Adjust	E
		Install Spreader Bracket	E
		Replace	E
	Loose Lashing	Repair	E
	Broken Splice	Replace	B
	Splice Tied In	Replace	E
Connector	Burnt	Replace	E
	Corroded	Repair	E
		Replace	E
	Incorrectly Installed	Replace	E
	Temp Differential	Replace	E
Insulation Deteriorated	Repair	E	
Crossarm	Broken/Damaged	Repair	E
		Replace	E
	Burnt	Repair	E
		Replace	E
	Decayed/Rotten	Repair	E
Replace		E	
Cutout	Broken/Damaged	Repair	E
		Replace	E
	Clearance Impaired	Adjust	E
	Flashed	Repair	E
		Replace	E
Decorative Streetlight	Broken/Damaged	Replace	E
	Missing	Install	E
Dead-End Cover (DCOV)	Broken / Damaged	Replace	F
	Broken / Damaged	Repair	F
Fault Indicators	Broken/Damaged	Replace	E
Fuse	Flashed	Repair	E



	Flashed	Replace	E
	Clearance Impaired	Adjust	E
	Broken	Repair	E
	Broken	Replace	E
Ground	Broken/Damaged	Repair	B
		Replace	B
	Exposed	Repair	F
	Missing	Install	E
Guy	Broken/Damaged	Repair	E
		Replace	E
	Clearance Impaired	Adjust	F
	Corroded	Repair	E
		Replace	E
	Loose	Adjust	F
	Missing	Install	F
	Overgrown	Trim	E
	Strain/Abrasion	Adjust	F
Remove		F	
Guy Marker	Missing	Install	F
		Replace	F
Hardware/Framing	Bird Prot. Required	Install	E
	Birdcage	Install	E
	Broken/Damaged	Repair	E
		Replace	E
		Remove	E
	Loose	Adjust	E
Missing	Install	E	
High Sign	Missing	Install	F
	Broken	Replace	F
Insulator	Broken/Damaged	Replace	E
	Flashed	Replace	E
	Primary Squatter	Repair	E
		Replace	E
	Secondary Squatter	Repair	E
Replace		E	
Jumper	Burnt	Replace	E
	Clearance Impaired	Adjust	E
		Replace	E
LAPP Insulator	Broken/Damaged	Replace	E
Lightning Arrester	Broken/Damaged	Repair	E



Job Aid: Overhead Assessment

TD-2305M-JA02

Publication: Jan 4, 2024, Effective: Feb. 1, 2024

Rev: 12

		Replace	E
	Flashed	Repair	E
		Replace	E
Marking	Broken/Damaged	Replace	F
	Missing	Install	F
Molding	Broken/Damaged	Repair	F
		Replace	F
	Loose	Adjust	F
	Missing	Install	F
OH Facility	Bird Prot. Required	Install	E
	Customer Related	Access	B
		Appointment	B
		Refusal	B
	Graffiti	Paint	E
	Idle Facilities	De-Energ	E
		Remove	F
		Transfer	F
	Limited Access	Inspect	B
		Patrol	E
		Remove	E
	Obstructed	Inspect	B
		Remove	E
		Replace	B
Transmission Issue	Create LC	B	
Bird Nest	Remove	E	
Operating Number	Broken / Damaged	Replace	E
	Missing	Install	E
Pole	Broken/Damaged	Pole Stub	E
		Re-Frame	E
		Repair	E
		Replace	E
	Burnt	Pole Stub	E
		Repair	E
		Replace	E
	Clearance Impaired	Repair	E
		Replace	E
	Decayed/Rotten	Pole Stub	E
		Pole Top Repair	E
		Repair	E
Replace		E	



	Idle Facilities	Remove	F
	Leaning	Adjust	E
		Replace	E
	No Safe Access	Inspect	B
	Overloaded	Replace	E
		Test	E
	Woodpecker Damage	Assessment	E
	Woodpecker Damage	Repair	E
Woodpecker Damage	Replace	E	
Soil Eroded	Replace	E	
Pole Step	Clearance Impaired	Remove	F
Recloser/Sectionalizer	Broken/Damaged	Repair	E
		Replace	E
	Excessive Operation	Overhaul	E
	Flashed	Repair	E
		Replace	E
	Leaks/Seeps/Weeps	Clean	E
Repair		E	
		Replace	E
Relinquished Pole	Decayed / Rotten	Remove	E
Riser/Pothead	Broken/Damaged	Repair	E
		Replace	F
	Flashed	Repair	E
		Replace	F
Installed in Error	Relocate	E	
RTVI	Interference	Repair	E
		Replace	E

SCADA/PDAC	Broken/Damaged	Repair	F
		Replace	F
	Leeks/Seeps/Weeps	Repair	F
		Replace	F
		Test	B
Secondary Service Conductor (SEC_SVC Conductor)	Splice Installed	Replace	F
Steel Lattice Pole	Guarding Missing	Install	E



**Job Aid:
Overhead Assessment**

Steel Lattice Tower	Broken/Damaged	Replace	E
Streetlight	Broken/Damaged	Repair	E
		Replace	E
	Missing	Install	E
Switch	Broken/Damaged	Repair	E
		Replace	E
Tree Wire	Exposed	Repair	F
Tie Wire	Broken/Damaged	Replace	E
	Loose	Replace	E
	Improperly Installed	Replace	E
	Corroded	Replace	E
Trans_Dist Pole	Bridging Broken	Repair	E
	Bridging Missing	Install	E
Transformer	Broken/Damaged	Repair	E
		Replace	F
	Corroded	Replace	E
	Flashed	Repair	E
		Replace	E
	Idle Facilities	Remove	F
	Leeks/Seeps/Weeps	Clean	B
		Repair	F
		Replace	E
		Re-Check	B
	No Common Neutral	Relocate	E
	Overloaded	Test	E
Parallel	Replace	E	
Tree/Vine	Clearance Impaired	Remove	E
		Trim	E
	Decayed/Rotten	Install CI Pole	E
	Overgrown	Remove	E
		Trim	E
Trip Saver	Broken/Damaged	Repair	E
		Replace	E
Under-Arm Bus	Broken/Damaged	Repair	F
Vis-Strips	Broken / Damaged	Replace	F