



Purpose and Scope

This gas design standard (GDS) outlines the requirements for complying with applicable federal and state codes when installing gas meter sets for residential and commercial premises.

This document includes definitions, references, and standard designs that support compliance with regulations and codes for gas meter set locations. Local jurisdictions may have adopted codes and ordinances relating to customer facilities that could require consideration when designing gas meter sets. Compliance with applicable federal and state codes is mandatory for Pacific Gas and Electric Company (PG&E or Company) facilities. Compliance with local codes is mandatory for customer facilities.

General Information

1. Applicability

- A. Per Gas Rule 16, "Gas Service Extensions," all gas meter set equipment must be located at a protected location on applicant's premises as approved by the Company. PG&E is responsible for the design and final approval of the location for metering facilities. The preferred meter set location is outside and adjacent to the building being served. Customers must submit the requested meter set location with the application early in the planning stage to avoid delays. Typically, PG&E provides only one meter set for each dwelling unit or commercial unit and one service lateral to each building.
- B. New or customer-requested relocated meter sets must be installed in compliance with current regulations, standards, and codes.
- C. Existing meter sets may be repaired, altered, or rebuilt in their existing location provided the clearance requirements meet or are brought up to current standards.
- D. These requirements do not mandate retroactive compliance of existing meter sets unless unsafe conditions exist as determined by the Company. If the existing service line or metering equipment is altered, then compliance with this gas design standard is required.

2. Applicable Regulations and Codes

Listed below are the pertinent Code of Federal Regulations (CFR) Title 49, Part 192—Transportation of Natural and Other Gas by Pipeline: Minimum Federal Safety Standards sections (§), that apply to gas meter set locations.

- 49 CFR § 192.353, "Customer meters and regulators: Location"
- 49 CFR § 192.355, "Customer meters and regulators: Protection from damage"
- 49 CFR § 192.357, "Customer meters and regulators: Installation"
- 49 CFR § 192.363, "Service lines: Valve requirements"
- 49 CFR § 192.365, "Service lines: Location of valves"

Note: All meter locations are subject to PG&E approval and review.

3. General Requirements

The following requirements comply with the regulations and codes.

A. General Meter Set Requirements

(1) Approved Meter Locations, listed in order of preference.

- (a) Meter set located outside a building.
- (b) Meter set located outside in an alcove or enclosure.
- (c) Meter set located in a breezeway.
- (d) Meter set located in a cabinet.

Note: PG&E considers approving Items (e) and (f) below only after Items (a) through (d) have been determined not possible or practical.

- (e) Meter set located in a buried vault, pit, or box (not permitted for new or remodeled services).
- (f) Meter set (excluding service shutoff valve) located inside a building in a gas meter room. See GDS J-16, "Gas Meter Room," for specific room requirements.

(2) Prohibited Meter Locations

For new or remodeled buildings, do not locate gas meter sets in the following areas:

- (a) In curb meter boxes or vaults for new services.
- (b) In living quarters, closets, toilet rooms, or bathrooms.
- (c) In garages without properly vented meter cabinets.
- (d) Behind fences that applicants can lock.
- (e) On steep slopes.
- (f) In areas where landscaping restricts access.
- (g) Within engine, boiler, heater, or electrical-equipment rooms.
- (h) Under display platforms or show windows in commercial buildings. This includes any permanent, elevated display floors or platforms associated with the window where the purpose of the window is to present a display to the public.

3.A. (continued)

- (i) In contact with the soil, in a depression below general ground level, or where potentially corrosive materials are likely to contact the meter set.
- (j) In a poorly-ventilated tradesman alley (passageway in a building, with a door at one end).
- (k) In crawl spaces under buildings or decks.
- (l) Near a driveway, drive-through, or other traveled area. Gas meters located in traveled ways must be adequately protected from passing vehicles, as described in GDS J-95, "Meter Guard Design and Installation Arrangement," Appendix C.
- (m) In a metallic cabinet, room, or location that blocks or interferes with the radio frequency signal transmissions that are necessary for PG&E to operate its SmartMeter™ Advanced Meter Reading system.
- (n) In any location that does not provide the required working space. The height dimension is 6 feet, 6 inches of clearance above ground and the depth dimension is 3 feet of clearance in front of the gas meter.

(3) SmartMeter Module Location Requirements

Specific SmartMeter module location requirements are detailed in Utility Manual TD-7001M, *Electric and Gas Service Requirements* (Greenbook), Section 2.4.F.12.

(4) Gas Meter Working Space

- (a) Gas meter locations must be 78 inches high and allow for a minimum clear and level working space of 3 feet in front of the meter; width depends on meter size and the number of meters. Grade slope should be less than 2%. See [Figure 1](#) and [Figure 2](#). For a large meter set or multi-meter manifold, this working space extends 12 inches beyond the edge of the Company meter set equipment.
- (b) [Figure 1](#) represents a typical gas meter kit with 0 through 350 scfh at 7 inches WC or 0 through 600 scfh at 2 pounds per square inch gauge (psig). Reverse sets are not allowed. The houseline must be to the right of the gas service riser.
- (c) [Figure 2](#) represents a typical gas meter kit with 351 through 1400 scfh at 7 inches WC or 601 through 2400 scfh at 2 psig. Do not use reverse sets for 400 through 600 class meters (i.e., 400, 425, and 630). The houseline must be to the right of the gas service riser.

3.A. (continued)

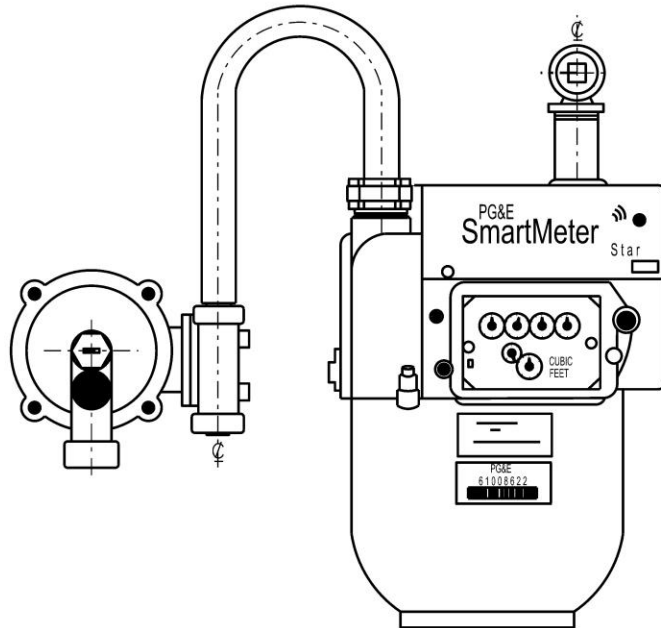
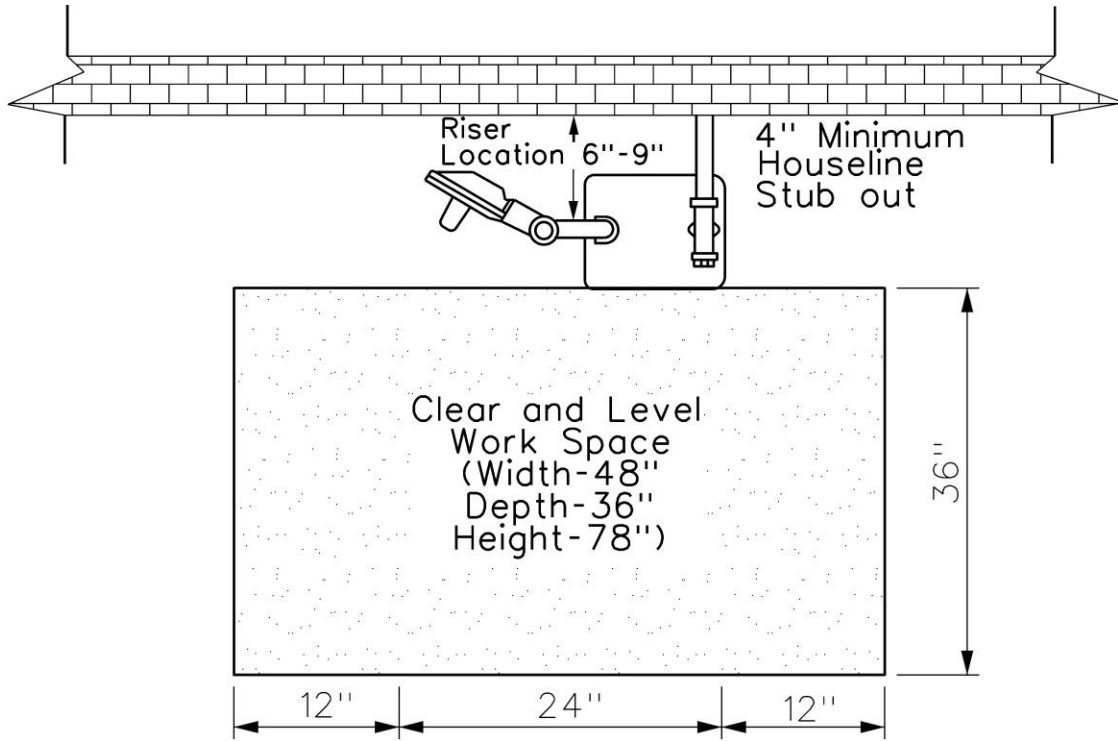

Figure 1. Typical Residential Gas Meter Connection

3.A. (continued)

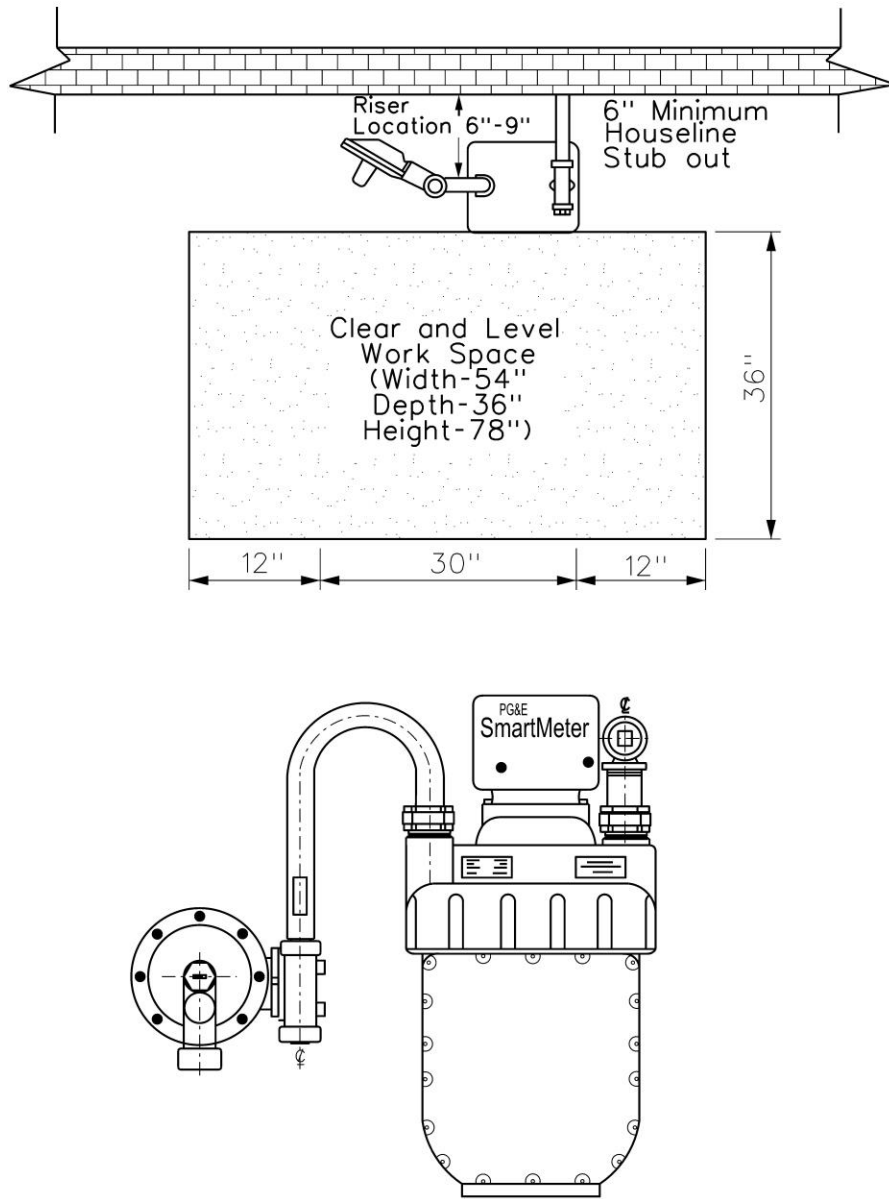

Figure 2. Typical Gas Meter Connection for 400 to 1000 Class Meter

(5) Meter Set Location Relative to Service Line

The meter set is typically located so that the service line is the minimum possible length, measured in a straight line perpendicular to the main. The Company may consider an alternate route if it results in significantly lower construction costs or facilitates construction.

3.A. (continued)

(6) Meter and Regulator Accessibility

Each meter set must be in a readily accessible location for reading, maintenance, inspection and replacement. It must be protected from corrosion and other damage that may be anticipated including vehicular damage. Large meter sets or multi-meter manifolds require adequate space for installation and maintenance and require drive-up access for the Company's service trucks.

(7) Service Shut-Off Valve Locations

(a) Each service line must have a shut-off valve in a readily accessible location when:

- Services or risers are newly installed, relocated, or completely replaced OR
- Work is performed under the Meter Protection Program

(b) The location for the service shut-off valve is above ground on an outside riser in a readily accessible location.

(c) Service risers must not be installed inside buildings or meter rooms, except where special circumstances prevent outside installation as determined by the Company in accordance with GDS J-16. If the riser is located inside a building or an outside riser valve is not readily accessible, then a curb valve must be installed in a location that is readily accessible.

(8) Meter Set Separated from Service Shut-Off Valve

If the meter set (or meter and regulator assembly) is located remotely from the service shut-off valve, then install an additional service shut-off valve at the meter set when performing new installations, replacing the meter, or altering or replacing the service. The additional valve facilitates maintenance and operation procedures.

(9) Meter Set Clearance Requirements

The meter set and service regulator vents must terminate in a safe outside location that complies with the following criteria.

(a) The regulator vent must not terminate near any sources of ignition or openings into the building. The riser must be a minimum distance of 36 inches from sources of ignition and openings into the building, and this clearance area extends 10 feet above and 36 inches below the regulator vent termination. (See [Figure 3](#).) For a large meter set or multi-meter manifold, this clearance requirement extends 12 inches beyond the last service tee or end of the manifold, whichever is greater, Company meter set equipment, 10 feet above the highest regulator vent, and 36 inches below the lowest regulator vent.

3.A. (continued)

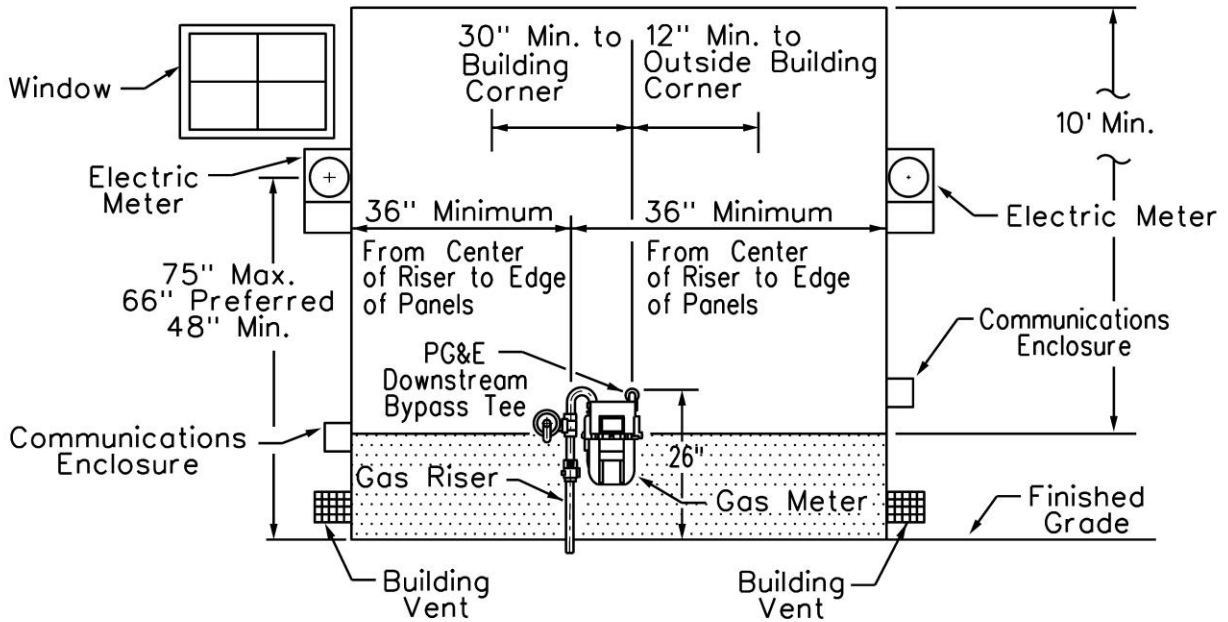

Figure 3. Gas Meter Set Separations

- (b) The regulator vent must not be within any location under building overhangs, where the overhang can direct gas into a building opening or any electrical devices under the overhang. Overhangs are acceptable if they direct gas away from a building (i.e., are sloped up and away from the building and cannot trap gas).
- (c) The riser must be a minimum lateral distance of 8 feet from a forced air intake into the building. (See [Figure 4.](#)) For a large meter set or multi-meter manifold, this clearance requirement extends 8 feet beyond the edge of the Company meter set equipment. The 8-foot distance extends around corners of the building.

3.A. (continued)

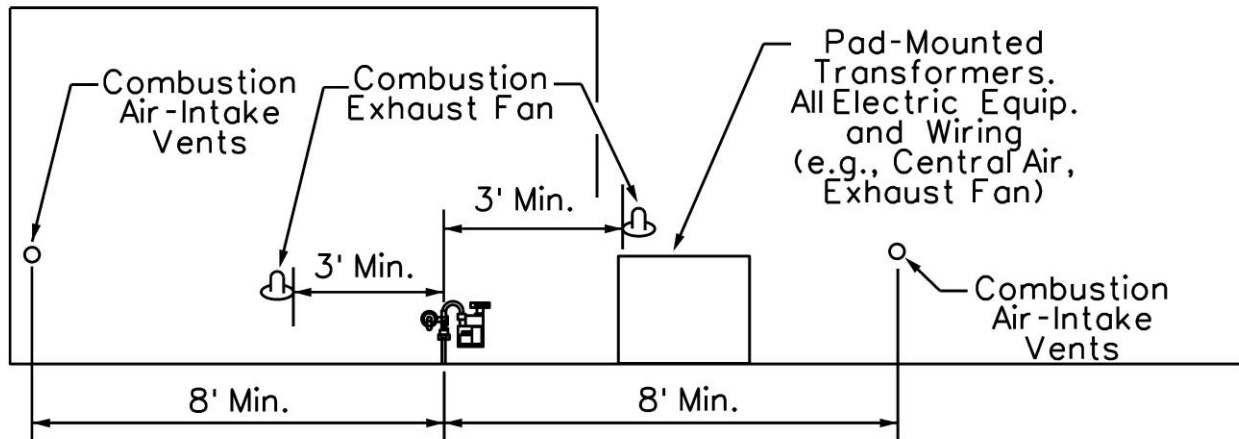

Figure 4. Requirements for Gas Regulator Set Clearance from Sources of Ignition

- (d) The meter set must not be within any location that is under display platforms or show windows in non-residential buildings, including any permanent, elevated, display floors or platforms associated with the window.

(10) Corrosion Protection

Each meter set and service line must be installed to provide protection from corrosion and anticipated damage. The service and meter set location must allow inspection for operation and maintenance activities.

(11) Meter Sets in Contact with Soil

Meter sets must not be installed in contact with the soil, in a depression below general ground level (curb meters are an exception), or where potentially corrosive materials are likely to contact the meter set. The potential for accidental electrical shunting of the insulating fitting must be minimized.

(12) Buried Lines Downstream of the Shut-Off Valve

On an exception basis, as approved by the company, if it is necessary to bury any segment of the metering facility downstream of the service shutoff valve such locations must have adequate corrosion protection.

3.A. (continued)

(13) Service Risers

- (a) Company-approved prefabricated, non-corrodible risers must be used. A minimum 3-inch casing will be required for the placement of the gas riser in areas that will be paved with concrete or asphalt. Gas service risers must not be directly embedded in concrete or asphalt pavements.
- (b) If it is necessary to pave (concrete or asphalt) before installing the gas service, refer to GDS A-75, "Gas Service and Mains in Plastic Casing."

(14) Overpressure Protection

When any overpressure protection devices are required in addition to the final service regulator, refer to GDS H-15, "Design Requirements for Company-Owned Gas Regulating Systems Serving Customers."

(15) Potential for Damage from Vehicles

Meter sets should be installed in locations where they are not exposed to damage from vehicular traffic. If there is a potential for damage to the meter set from vehicular traffic, refer to GDS J-95.

(16) Working Space Around Electric Meter Sets

To provide required working space around an electric meter, the gas service riser may not be located less than 36 inches laterally from the closest edge of the electric meter panel. (See [Figure 3](#).) For a large gas meter set or multi-meter manifold, this clearance requirement extends 12 inches laterally beyond the edge of the Company gas meter set equipment.

(17) Other Hazards

When selecting the meter set location, it is necessary to be alert to any potential hazards not specifically indicated in this document, including potential risk to others caused by the meter set, and exercise reasonable care to avoid any hazards. Electric grounding or bonding wires must not be attached to any part of the gas meter set. No bonding is permitted within 36 inches of PG&E meter set assembly on the customer houseline.

(18) Service Delivery Point

- (a) All customer-installed equipment must be installed downstream of the Company point of connection as shown in [Figure 5](#). Customer-installed equipment may include: earthquake valves, seismic shutoffs, remote monitoring equipment, or flex hoses. Any customer-installed equipment on Company facilities must be removed at the customer's expense.
- (b) Company point of connection must be made to rigid pipe houseline and not to flex line.

3.A. (continued)

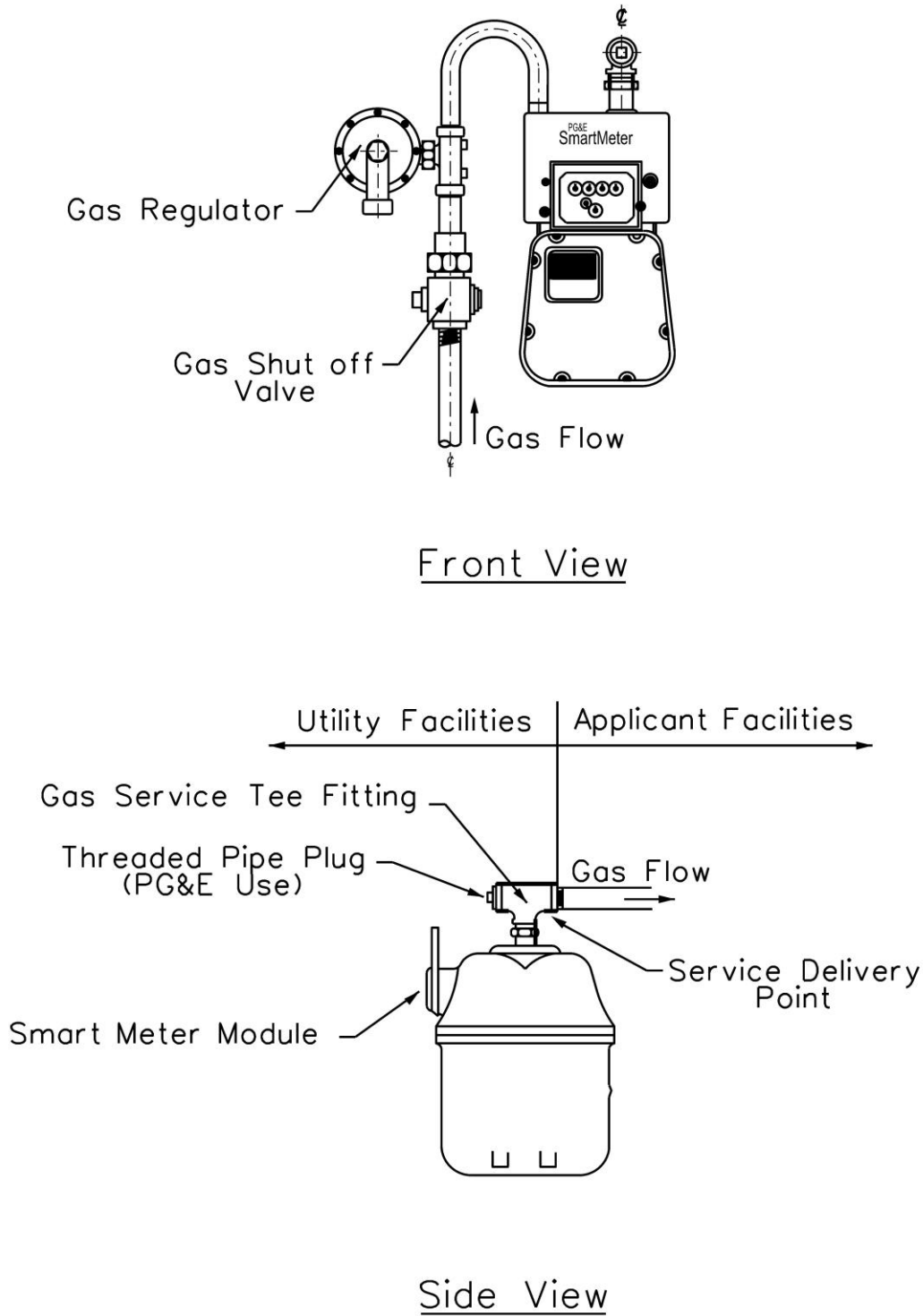

Figure 5. Typical Residential/Small Commercial Meter

B. Specific Requirements for Outside, Aboveground Meter Sets

(1) Location

Meter sets should be located at the building and as near as practical to the point where the gas service pipe enters the property. The meter set location is typically near the side of the building from which the customer will be served. The order of preference for locating the outside, aboveground meter set is as follows.

- (a) In a protected location adjacent to the building served (see Figure 6, below). An exception to this requirement is for schools, where it is required to protect the meter set by installing it in a location that is separated from buildings and playground areas. It will be necessary to install a protective enclosure or wire cage with a cover around the meter set in these cases. (See [Figure 7](#) and [Figure 8](#).)
- (b) At the customer's property line, if a location exists where the meter set can be properly protected from damage by vehicles and anticipated damage. The service and meter set location must allow inspection for operation and maintenance activities. (See [Figure 9](#).)

(2) Meter Set Accessibility

For ease of access, avoid locations behind fences or other barriers that may be kept locked by the customer.

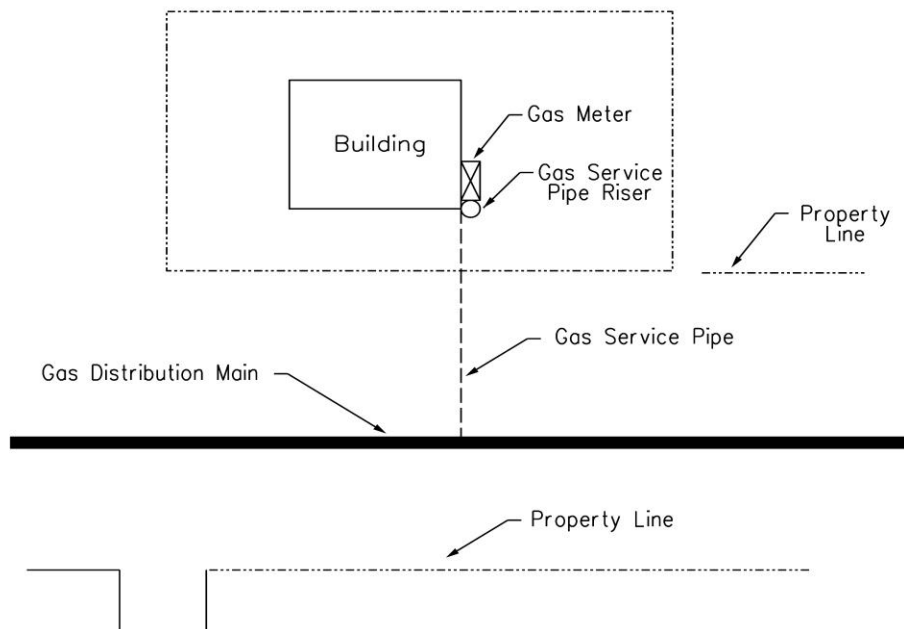

Figure 6. Gas Service

3.B. (continued)

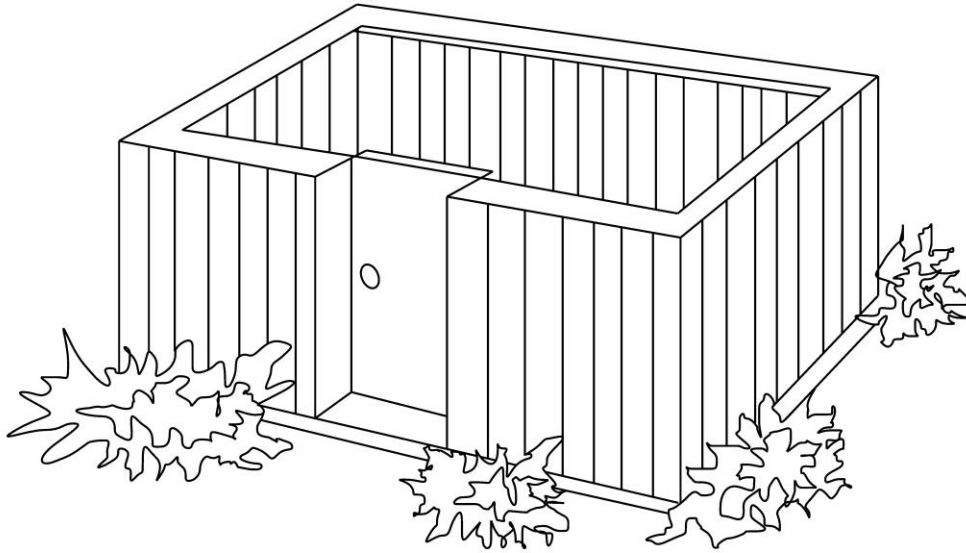
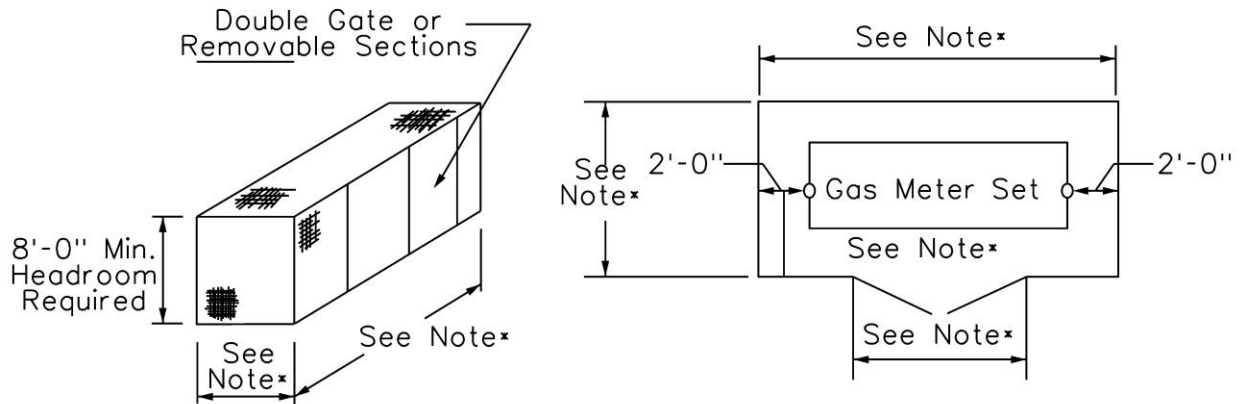

Figure 7. Typical Detached Enclosure



* The enclosure's width and length will vary depending on the meter set. Contact your local PG&E project coordinators (formerly service planners) for more information.

Figure 8. Typical Enclosure Dimensions

3.B. (continued)

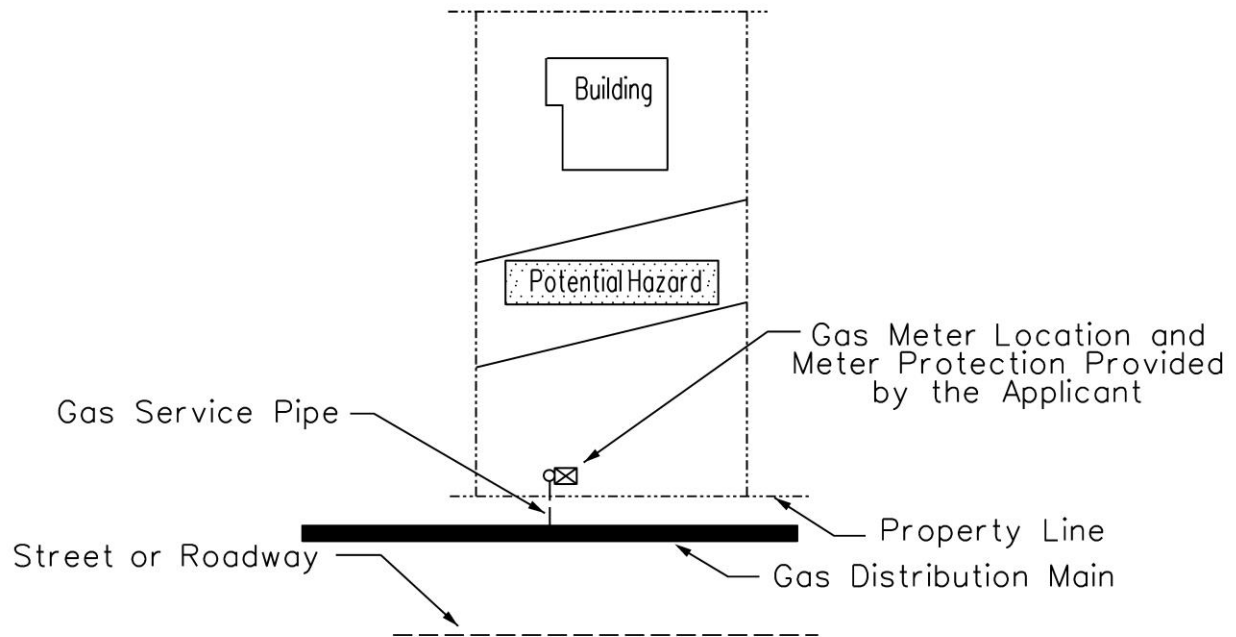

Figure 9. Property Line Installation

C. Specific Requirements for Meter Sets Located in Alcoves

- (1) An alcove's width can vary depending on the meter set. The height of the alcove is typically 8 feet; the depth must not exceed 36 inches. PG&E provides final dimensions after confirming the meter size and the number of meters.
- (2) A manifold located in an alcove may require a custom design depending on the configuration.
 - (a) For single-diaphragm meters, applicants must use the area dimensions shaded in [Figure 1](#) and [Figure 2](#).
 - (b) Single-rotary meters or multi-meter manifolds may require a custom design depending on the configuration.
 - (c) A gate is not a preferred option and requires approval on an exception basis. If a gate is proposed in front of the alcove, it must have at least 50% open area.
 - (d) No lighting, wirings, foreign pipes or other facilities are allowed in the alcove.

D. Specific Requirements for Meter Sets Located in Breezeways

(1) Isolation from Living Spaces

Meter sets installed in breezeways must be located so that gas cannot migrate into building openings.

(2) Ventilation

Meter sets may be installed in breezeways that are adequately ventilated to the outside atmosphere. The breezeway must be open at both sides.

(3) Separation from Sources of Ignition

No sources of ignition are allowed in the breezeway. Any electric wiring, switches, light fixtures, or circuit breakers must meet the requirements of the National Electric Code for installation in Class 1, Division 2 areas.

E. Specific Requirements for Meter Sets Located in Cabinets or Gas Closets

- (1) Meter cabinets are not a preferred method of installation. A meter cabinet larger than for single domestic meter installations requires prior approval from the local field services manager. When approved, it must comply with the requirements in this section.
- (2) It is preferred to have regulators installed on the outside of the cabinet. Additional space is required for larger regulators and dual-head regulators. Installing the regulators in a cabinet requires prior approval from the local field services manager. If there are regulators in a cabinet, then the vents must be piped out of the cabinet per GDS H-93, "Piping – Details, Regulator Vent Lines - Above Ground."
- (3) Meter sets and meter set components located in a cabinet must have adequate working space, proper ventilation, and no source of ignition. See GDS K-51, "Single Meter Cabinet for Domestic Gas Meters," for single meter cabinet requirements and details. Final cabinet dimensions must be approved by Company prior to construction for other than single domestic meter size.
- (4) Cabinets must be designed to be vapor-proof and prevent migration of gas into the interior of a building or other location where gas may create a hazard. The cabinet must be constructed of non-metallic and non-combustible material with non-metallic doors, and open to the outside.
- (5) Meter cabinets that have been constructed prior to acceptance by Company may not be approved. Submitting these requests with the application early in the planning stage reduces delays.
- (6) Modifications to existing gas meter sets in cabinets must comply with current codes and standards.

3.E. (continued)

- (1) Cabinets are limited to a minimum depth of 18 inches and a maximum depth of 36 inches. See Figure 10, below, for specific meter cabinet sizes and clearances. Cabinets deeper than 36 inches must conform to the requirements of GDS J-16.

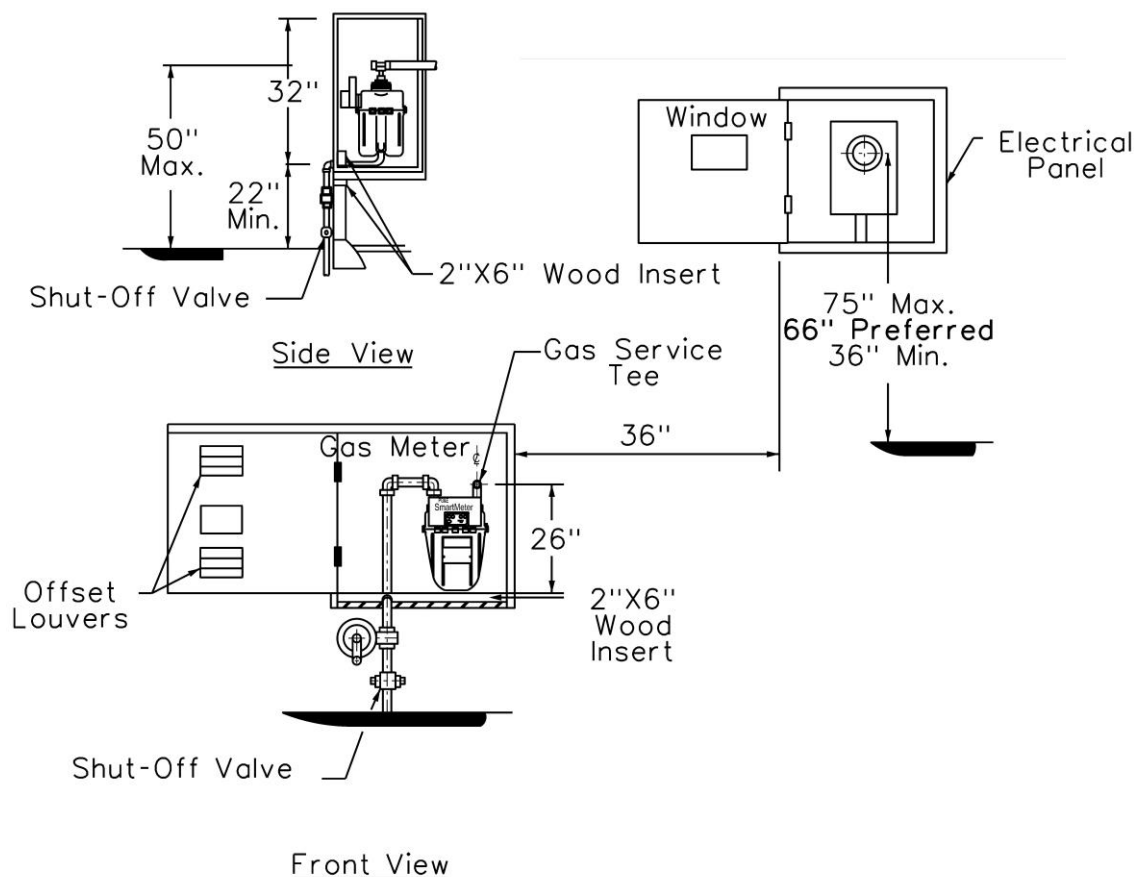

Figure 10. Specifications for a Recessed Individual Meter Cabinet

(2) Gas Meter Closets

- (a) Gas meter closets must be furnished and installed by the applicant and have a depth of 18 inches minimum and 36 inches maximum, without exception. Doors must be non-metallic and fully louvered.
- (b) Doors must open at least 90° and have a clear opening height of 6 feet, 8 inches.
- (c) The inside of the closet must be made of non-flammable material and have a minimum 1-hour fire rating. All joints and penetrations must be sealed to prevent gas from migrating into the structure. Foreign pipes are not allowed inside the closet with the exception of fire sprinkler heads. Lighting, wiring, conduits, junction boxes, or inspection panels of any kind are not allowed inside the closet. Bonding or grounding wires on the customer's houelines are not allowed inside the closet.

3.E. (continued)

- (d) The ceiling must have a 1:12 slope. The ceiling must slope up toward the door frame with a maximum of 6 inches measured from the door opening to the finished ceiling.
- (e) The inside width of the closet cannot exceed 8 inches beyond either side of the door frame. Refer to Section 3.H, below, for manifold spacing to determine the size of closet required for the desired number of meters. The meters and manifold must fit within the opening of the closet doors with the exception of the tie-in piece from the outside riser.
- (f) The riser and regulator must be installed outside of the closet. The applicant provides a penetration through the wall into the closet. Contact your local project coordinator for the exact size and location of the required penetration.
- (g) The doors must have the identifying sign "Gas Meters." If the doors have locks, the applicant must install a lock box near the closet that is acceptable to PG&E and contains a key.
- (h) The closet cannot be used for storage of any kind. Only PG&E gas meters and metering appurtenances are allowed inside the closet.

F. Specific Limitations for Curb Meter Sets

- (1) The Company considers curb meter installations undesirable because they are difficult to maintain. See GDS J-14.1, "Curb Meter Installations," for a description of the policy and design considerations for curb meter installations. Depending on the size and type of facilities, required equipment may not be available or suitable for use below grade.
- (2) Large Meter Installations for Commercial or Industrial Loads

On an exception basis, a vault or meter box may be located on the customer's property, either adjacent to the building served or near the property line.

G. Specific Requirements for Meter Sets Located Inside Buildings

Meter sets and all meter set components located inside buildings must be contained within a dedicated gas meter room, as specified in GDS J-16.

H. Multi-Meter Manifolds

Multiple meters will be at one approved location for each property or location. Number of meters, tiers and size of piping are designed by the Company. See GDS J-52.1, "Gas Meter Manifolds (1-1/4" and 2" Sizes)," GDS J-52.2, "Brackets for Gas Meter Manifolds," and GDS J-52.3, "Gas Meter Manifolding." The Company limits gas meter manifold configurations to one-tier or two-tier meter manifolds not exceeding 60 inches high. These manifolds are measured from the final level standing surface to the top of the manifold. See [Figure 11](#) and [Table 1](#).

3.H. (continued)

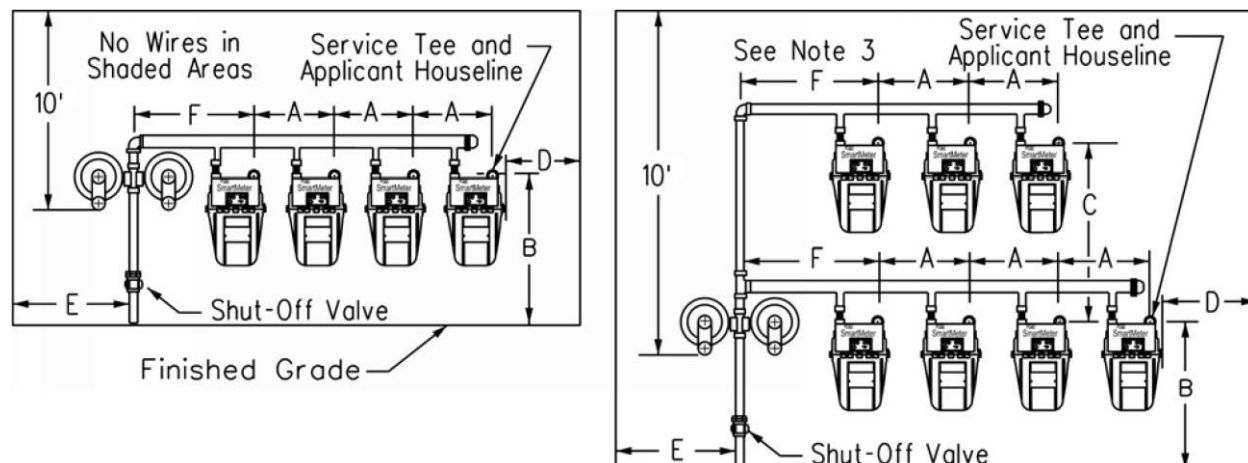

Figure 11. Typical Multimeter Installations

Notes for Figure 11

1. The applicant's houselines must be stubbed out 4 inches to 6 inches from the finished wall at the locations shown.
2. The applicant must clearly mark each houseline.
3. Applicants must not install any electrical devices or equipment, including wires, cables, metering enclosures, telecommunication enclosures, bond wires, clamps, or ground rods within 36 inches horizontally from the farthest edge of PG&E facilities and 10 feet above the regulator vent.
4. Applicants may need to install the riser farther away from the building to accommodate the manifold installation. Consult your local project coordinator for site-specific details.

Table 1. Dimensions for Figure 11

Label in Fig. 11	Installation Dimensions	Comments
A	12" for residential only 15" for cabinet installations only 20" for all commercial meters up to 1000 class	PG&E provides custom-design dimensions for mixed meter sizes and for meters larger than 1000 class.
B	26" (typical) for unenclosed 32" (typical) for cabinet installations	-
C	24" residential (unenclosed and cabinet) 36" commercial	Contact local project coordinator for two-tier commercial manifolds.
D	6" min. to inside building corner 12" min. to outside building corner 36" to electrical wired (see Note 3)	From farthest edge of PG&E equipment.
E	30" min. to inside or outside corner of building 36" min. to electrical wires (see Note 3)	PG&E may approve reduction of Dimension E on a case-by-case basis – e.g., in non-pedestrian traffic areas, or on select PG&E equipment.
F	24" (typical) for residential 36" (typical) for 400 to 1000 class meter, commercial	PG&E provides custom-design dimensions for mixed meter sizes and for larger than 1000 class meters.

3.H. (continued)

Note: The Company does not install meters unless the permanent address, the location, or the area being served (if applicable) is marked at each meter location.

- I. The Company requires that buildings, dwellings, occupancies, houselines, or other facilities or locations be marked to identify gas lines that are serving locations or supplying equipment. Applicants must ensure that the following rules for marking houselines are enforced.
 - (1) The Company requires that lines be marked by attaching an embossed, durable, metal or plastic tag to each houseline. The Company must approve of the tag.
 - (2) Markings must be legible and specific.
 - (3) Marking information must include an authorized apartment or street number and a use or location designation.
 - (4) The houseline must be permanently, clearly, and prominently marked at the point of the service connection (i.e., service delivery point).

J. Protecting Meter Sets From Vehicular Damage

- (1) Meter Sets in Traveled Areas

If any portion of a gas meter set must be located in or adjacent to traveled areas where there is the probability of vehicular damage, physical protection acceptable to the Company must be provided by the customer. The Company determines when such protection is required. Physical protection must be provided for any gas meter, per GDS J-95.

- (2) Returning Damaged Meter Sets to Service

If a meter set is damaged by a vehicle or other equipment and there is a potential for a recurrence, temporary barricading must be installed before service is restored, and until permanent protection is installed, per GDS J-95, or the meter is relocated.

Target Audience

Personnel who work in design, engineering, estimating, field services, maintenance and construction (M&C), gas pipeline operations and maintenance (GPOM), and general construction.

Definitions

Alcove	Exterior space that is recessed into a building. The alcove's width can vary depending on the meter set. PG&E provides final dimensions after confirming the meter size.
Breezeway	A passage or walkway with full openings on both sides. No sources of ignition or openings into the building.
Cabinet	A structure, not deeper than 36 inches, with a solid or closed top that is freestanding, attached or recessed into a building exterior wall, vapor proof from the building, with access doors for the purpose of containing/protecting a gas meter set or meter set components.
Enclosure	A structure with an open top that is freestanding or attached to a building exterior wall with access doors; a cage; or walls and gate for the purpose of containing/protecting a gas meter set or meter set components.
Gas meter room	A space within a building that is solely used to house natural gas metering equipment in accordance with GDS J-16, "Gas Meter Room."
Meter set	The gas meter, service regulator, overpressure protection devices, and all associated Company piping and fittings between the service riser valve and the customer houseline.
Readily accessible location	<p><i>For a gas meter set:</i> The preferred location can be accessed immediately and does not require contact with the owner or occupant. If the preferred location is unavailable, the Company may approve a lock box with key for access.</p> <p><i>For a service shut-off valve:</i> The preferred location is outside and aboveground. If the preferred location is unavailable, the Company may approve a curb valve in which no permanent structure prevents immediate valve access or operation.</p>
Show window	A ground floor window in the wall of a commercial building, including any permanent elevated display floors or platforms associated with the window, where the purpose of the window is to present a display to the public.
Source of ignition	As defined by the National Fuel Gas Code Handbook, sources of ignition are defined as "devices or equipment that, because of their intended modes of use or operation, are capable of providing sufficient thermal energy to ignite flammable gas-air mixtures." This includes electric wiring, switches, and circuit breakers that do not meet the requirements of the National Electric Code for installation in Class 1, Division 2 areas.

Acronyms and Abbreviations

CFR: Code of Federal Regulations
CPUC: California Public Utilities Commission

Compliance Requirement/Regulatory Commitment

Code of Federal Regulations (CFR) Title 49, Transportation, Part 192—Transportation of Natural and Other Gas by Pipeline: Minimum Federal Safety Standards, Section (§) 192.353, “Customer meters and regulators: Location”

CFR 49 § 192.355, “Customer meters and regulators: Protection from damage”

CFR 49 § 192.357, “Customer meters and regulators: Installation”

CFR 49 § 192.363, “Service lines: Valve requirements”

CFR 49 § 192.365, “Service lines: Location of valves”

Records and Information Management:

Information or records generated by this design standard must be managed in accordance with the Enterprise Records and Information (ERIM) Policy, Standards and Enterprise Records Retention Schedule (ERRS). Refer to GOV-7101S, “Enterprise Records and Information Management Standard,” and related standards. Management of records includes, but is not limited to:

- Integrity
- Storage
- Retention and Disposition
- Classification and Protection

References

California Public Utilities Commission (CPUC) General Order 112-F, “State of California Rules Governing Design, Construction, Testing, Operation, and Maintenance of Gas Gathering, Transmission, and Distribution Piping Systems”

Gas Design Standard (GDS) A-75, “Gas Service and Mains in Plastic Casing”

GDS A-90, “Polyethylene Gas Distribution System Design”

GDS H-15, “Design Requirements for Company-Owned Gas Regulating Systems Serving Customers”

GDS H-91, “Vent Cover for Regulator on Curb Meter Sets”

GDS H-92, “Plastic Vent Caps”

GDS H-93, “Piping – Details, Regulator Vent Lines - Above Ground”

References (continued)

GDS J-14.1, "Curb Meter Installations"

GDS J-16, "Gas Meter Room"

GDS J-52.1, "Gas Meter Manifolds (1-1/4" and 2" Sizes)"

GDS J-52.2, "Brackets for Gas Meter Manifolds"

GDS J-52.3, "Gas Meter Manifolding"

GDS J-95, "Meter Guard Design and Installation Arrangement"

GDS K-10, "Precast Concrete Pit"

GDS K-10.1, "Precast Concrete Vaults & Pits"

GDS K-40, "Plastic Valve Box for 3/4" – 4" Valves"

GDS K-40.1, "Method of Installing Concrete Curb Boxes in Concrete Sidewalk"

GDS K-42, "Precast Boxes"

GDS K-42.1, "Precast Boxes 13" x 24" and 17" x 30"

GDS K-51, "Single Meter Cabinet for Domestic Gas Meters"

Gas Rule 16, "Gas Service Extensions"

NFPA 70: National Electric Code (NEC)

Utility Manual TD-7001M, *Electric and Gas Service Requirements* (Greenbook), Section 2, "Gas Service"

Utility Standard S4446, "Vault Inspection Procedure"

Appendices

NA

Attachments

NA

Revision Notes

Revision 9b has the following changes:

1. Changed K-42 document title from "Precast Boxes 17" × 30", 24" × 36", 30" × 48", and 36" × 60"" to "Precast Boxes," in References.

Revision 9a (Publication Date: 08/18/2021 Effective Date: 11/01/2021) has the following changes:

2. In 3.A.(13).(a), removed requirement to install a protective sleeve or "sunshield."

Revision 9 (Publication Date: 11/15/2017 Effective Date: 11/29/2017) has the following changes:

3. Updated Purpose and Scope.
4. Updated Applicability.
5. Updated Definitions.
6. Added figures from Electric and Gas Service Requirements (Greenbook).
7. Added language requiring meter sets in cabinets to be approved by Field Services Manager.

Asset Type: Customer Connected Equipment

Function: Design and Construction

Document Contact: [Gas Design Standard Responsibility List](#)