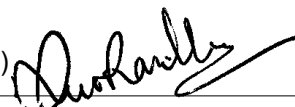
	<b>ELECTRICAL SERVICE REQUIREMENTS FOR MOBILE HOME DEVELOPMENTS</b>	<b>052521</b>
<b>Asset Type:</b> Electric Metering		<b>Function:</b> Construction
<b>Issued by:</b> Quoc Hoang (QxH1) 		<b>Date:</b> 11-01-18
<b>Rev. #07:</b> This document replaces PG&E Document 052521, Rev. #06 For a description of the changes, see Page 8.		

**This document is also included in the following manuals:**

- [Electric Meter Work Practices](#)

**Purpose and Scope**

This document shows methods of supplying underground electric service to meter equipment (pedestal) serving mobile homes in accordance with [Electric Rule 15](#) and [Electric Rule 16](#) for a park that qualifies as a mobile home development as defined by PG&E. Additionally refer to PG&E's Electric and Gas Service Requirements manual ([Greenbook](#)) for additional requirements that may not be listed in this document.

Note: In accordance with Title 25, Article 7, Sections 1322, 1333, and 1333.5, mobile homes installed on foundation systems in locations other than mobile home parks, may be served by PG&E from overhead or underground service to the customer's equipment (service entrance conductors if overhead), which is attached directly to the mobile home. Refer to PG&E [Document 063927](#) for underground service requirements and [Documents 025202](#) and [022169](#) for overhead service requirements.

**Instructions**

1. The developer or his contractor shall provide all necessary trenching, secondary and service conduit (when required), and shall be responsible for the location and final grade of the utility islands
2. The required location for the meter equipment is at the front of the mobile home (see Figure 1 on Page 4). Alternate locations for the meter pedestal are indicated by the shaded areas in Figure 1 on Page 4.
3. PG&E shall install the secondary and service lateral cables in accordance with current engineering standards and construction methods.
4. Maintain a 36-inch (minimum) work space clearance from the meter face and from any access panel to PG&E facilities on the enclosure. Maintain a 36-inch (minimum) clearance from the meter equipment to other utility equipment such as gas, water or sewer. Refer to the National Electrical Code and the Authority Having Jurisdiction for the allowed working space requirements and if the 36-inch (minimum) clearance shown in Figure 3 and Figure 4 on Page 5 may be reduced to 12 inches for pedestal designs which have the meter and all access panels (both PG&E's and customer's) located on the same side of the pedestal.
5. Before PG&E has installed the cable, the developer or his contractor shall then:
  - A. Install the electric meter pedestal in place over the conduit. Position the pedestal so the meter socket faces toward the street as shown on Page 5 or away from mobile home. Maintain the work space and clearances as described in Note 4.
  - B. Install and connect a copper grounding conductor from the pedestal grounding lug to an N.E.C. approved ground electrode system. The grounding connection shall not be made to a gas piping system. The customer shall be responsible for bonding and grounding all exposed non-current-carrying metal parts in accordance with the applicable electric codes and local ordinances. PG&E prefers, but does not require, the grounding electrode conductor wire to be protected against physical damage by rigid steel conduit or armored cladding. Refer to the NEC for any required clearance distance of the ground rod away from the pedestal. The top of the ground rod may be exposed or buried as required to meet the applicable electric codes. Exposed ground rods should be placed so they are not a tripping hazard.
  - C. Bond the service neutral termination lug to the meter pedestal by means of a bonding screw, or by continuing the grounding conductor between the grounding lug and the neutral lug.

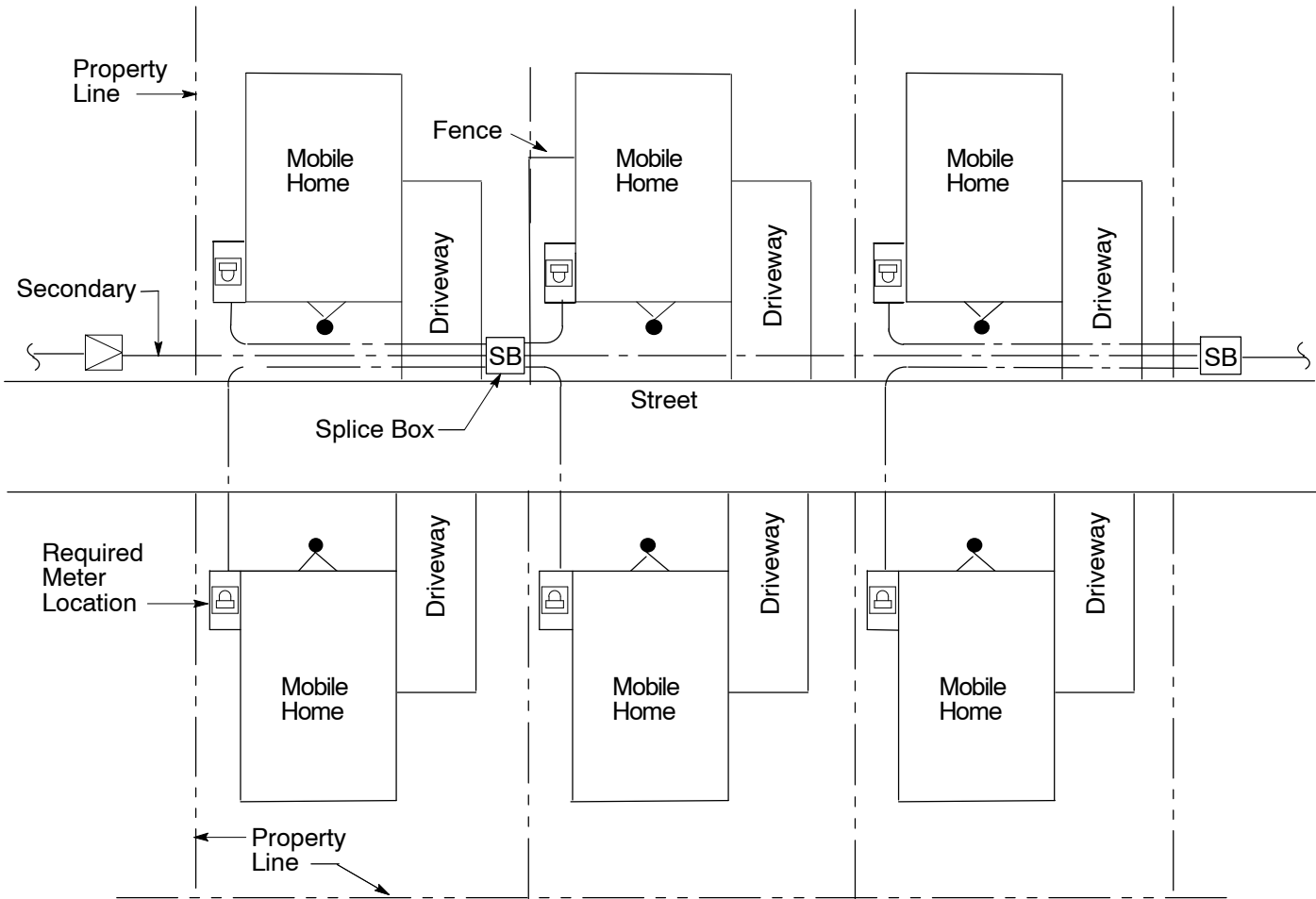
- D. Backfill around the pedestal to provide good support, plumb and level the pedestal, and pour the concrete base support or island. The concrete surface should be no more than 1-inch above grade and 1-inch to 2-inch below the bottom of the utility section opening.
  - E. Backfill all trenches, and furnish any imported backfill material required.
6. PG&E shall connect the service lateral conductors to the termination lugs in the meter pedestal, install and seal the pull section panel, and blank off and seal the meter socket.
  7. PG&E shall set the meter upon request for service, after required permits and inspections have been obtained from city or county inspection authorities.
  8. See Figure 1 on Page 4 for a typical electric distribution system layout for a mobile home development.
  9. PG&E shall design its facilities so that the short-circuit duty at the electric service entrance will not exceed 10,000 amps.
  10. Mobile home pedestal shall have a minimum rating of 100 amps. The socket and enclosure shall be designed in accordance with PG&E [Document 051001](#) and the following:
    - A. The minimum meter height shall be 36 inches when the meter is enclosed, or 48 inches if the meter is exposed.
    - B. When the meter is enclosed, the enclosing cover shall be hinged for ready access and shall have a shatter-proof reading window. When the meter is enclosed or recessed, the clearance from the meter centerline to any fixed side obstruction shall be a minimum of 6 inches.
    - C. The service cable pull and terminating section shall be covered with a sealable removable panel (or panels), extending from a fixed panel 1 to 2 inches above concrete. The removable panel shall allow full access to the service terminating lugs. Access to the service terminating lugs may be from either front or rear of the pedestal.
    - D. Service terminating lugs shall be twin #6 to 350 kcmil range, aluminum bodied pressure type for connecting a single-service lateral.
    - E. Lugs for terminating the user's neutral conductors shall be located outside the sealable section and shall be designed to readily permit his neutral system to be isolated, when necessary, from PG&E's neutral.
    - F. The pedestal at grade line shall have the minimum dimensions as specified on Page 8.
    - G. The minimum depth of the pedestal in the ground shall be 24 inches.
    - H. Adequate ventilation shall be provided to prevent moisture condensation inside the pedestal, as required by UL414.
    - I. Any unmetereed bus going through the breaker section shall be completely covered by steel or approved plastic conduit.
  11. Installation of PG&E distribution system facilities including service and metering equipment installations shall be designed and constructed in accordance with PG&E's Electric and Gas Service Requirements. Refer to the applicable sections in the [Greenbook](#) manual for additional requirements that may not be listed in this document.
  12. Physical protection from vehicular traffic shall be provided in accordance with the level of vehicular exposure. Barrier posts are intended to provide reasonable warning from accidental vehicular contact, rather than to prevent all possible contact. The applicant will provide acceptable physical protection. Refer to [Document 051122](#), Clearances and Location Requirements for Enclosures, Pads, and Underground Equipment.

**Electrical Service Requirements for Mobile Home Developments**

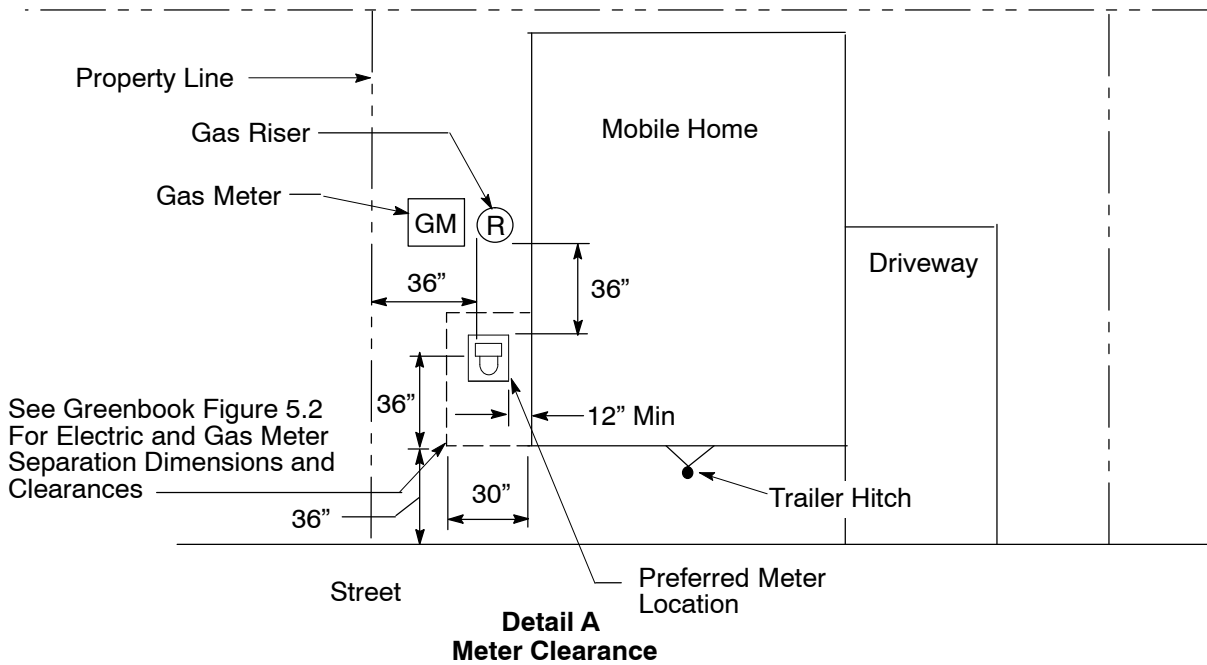
---

<b>References</b>	<b>Location</b>	<b>Document</b>
<a href="#">Connectors for Insulated Cables</a>		
<a href="#">Underground Distribution Systems</a> .....	<a href="#">UG-1: Connectors</a> .....	<a href="#">015251</a>
<a href="#">Clearances for Supply Service Drops</a> .....	<a href="#">OH: Services</a> .....	<a href="#">022169</a>
<a href="#">Methods of Attaching Services to Customer Premises</a> ..	<a href="#">OH: Services</a> .....	<a href="#">025202</a>
<a href="#">Temporary Underground Electric Service Single-Phase, 120/240 Volt, 200 Amps Maximum</a> .....	<a href="#">UG-1: Services</a> .....	<a href="#">036670</a>
<a href="#">Cables for Underground Distribution</a> .....	<a href="#">UG-1: Cable</a> .....	<a href="#">039955</a>
<a href="#">Clearances and Location Requirements for Enclosures, Pads, and Underground Equipment</a> .....	<a href="#">UG-1: General</a> .....	<a href="#">051122</a>
<a href="#">Terminating Underground Electric Services 0 – 600 Volts in Customer-Owned Facilities</a> .....	<a href="#">UG-1: Services</a> .....	<a href="#">058817</a>
<a href="#">Methods and Requirements for Installing Residential Underground Electric Services 0 – 600 to Customer-Owned Facilities</a> .....	<a href="#">UG-1: Services/Greenbook/EDM</a> .....	<a href="#">063927</a>

# Electrical Service Requirements for Mobile Home Developments



**Figure 1**  
**Typical Electric Distribution System for a Mobile Home Development**

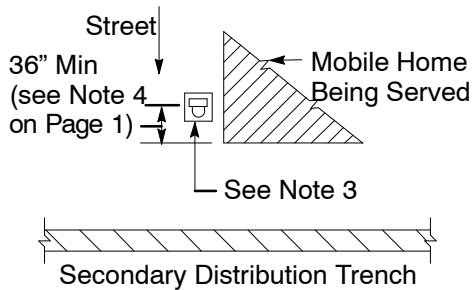


# Electrical Service Requirements for Mobile Home Developments

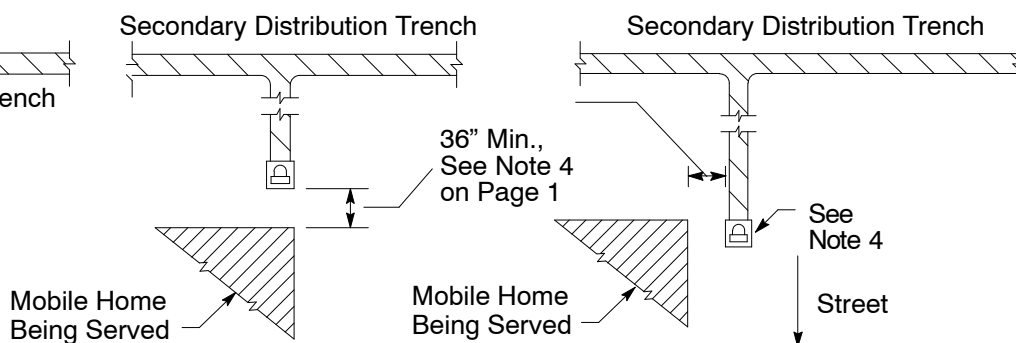
## Location of Electric Meter Pedestal

### Notes

1. Position pedestal so that electric meter is faced toward the street or right of way.
2. See Figure 5 and Detail B.
3. Position pedestal so that electric meter is facing away from mobile home, towards right of way.
4. Alternate location for pedestal. Position pedestal so that electric meter is facing away from mobile home.
5. Trench depth shall be 30 inches (minimum) with or without gas service, and greater if joint with a gas main.

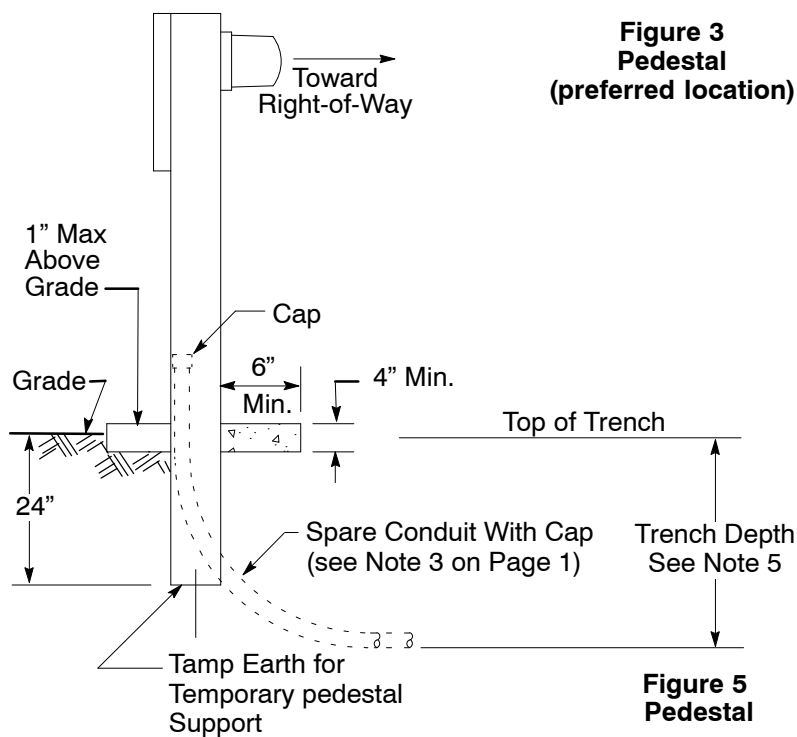


**Figure 2  
Pedestal  
(preferred location)**

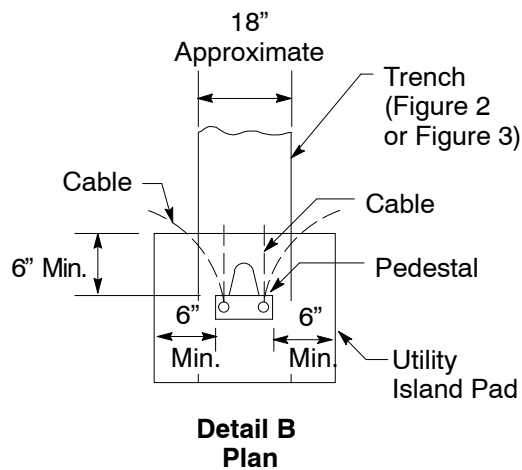


**Figure 3  
Pedestal  
(preferred location)**

**Figure 4  
Pedestal  
(alternate location)**



**Figure 5  
Pedestal**



**Detail B  
Plan**

**Material**

**Notes**

1. It is recommended that the main circuit breakers used in pedestals have a 10,000-amp short-circuit current rating to insure compliance with state and local codes. These codes require that the main breaker of service equipment be rated at the available short-circuit current. PG&E shall design its facilities to supply all new mobile home customers so that the short circuit duty at the pedestal will not exceed 10,000 amps.
2. See Table 2 on Page 6 for a list of approved meter pedestal manufacturers and catalog numbers.
3. Pedestals are allowed to have rear connection kit.

**Table 1 List of Material for Supplying Electric Service to Mobile Home Developments**

Item	Description
Material to Be Supplied by Applicant	
1	Meter Pedestal (as required, see Table 2 on Page 6 for the approved list)
2	Conduit, Rigid Steel, Galvanized, with Pipe Strap (for bare ground wire, omit if armor clad wire is used)
3	Hub and Clamp, Grounding (to suit Item 3)
4	Conduit Fitting, Threaded, With Cover and Gasket (size to suit Item 3)
5	Ground Rod (see Instruction 5B on Page 1)
6	Ground Wire, Copper, Bare, or Armor Clad (size in accordance with applicable electrical codes and local requirements)
7	Conduit and Cap (as required)
Material to Be Furnished by PG&E	
8	Cable, XLP, 600-V (as required), see <a href="#">Document 039955</a> (see Table 2)

**Table 2 Approved Meter Pedestals <sup>3</sup>**

Rating (amps)	Mobile Home Electric Metering Pedestals	
	Manufacturer	Catalog Number
0 – 125	Myers Elec. Prod.	MES-M100SE
	MILBANK	MPRV Series
0 – 200	Myers Elec. Prod.	MES-M200SE
	MILBANK	MPAP Series
	MILBANK	U6276 Series

- <sup>1</sup> See Notes on Page 6.
- <sup>2</sup> Pedestals can have rear connection kits.
- <sup>3</sup> Other meter pedestal that meet EUSERC 307 and PG&E requirements may be allowed.

## Electrical Service Requirements for Mobile Home Developments

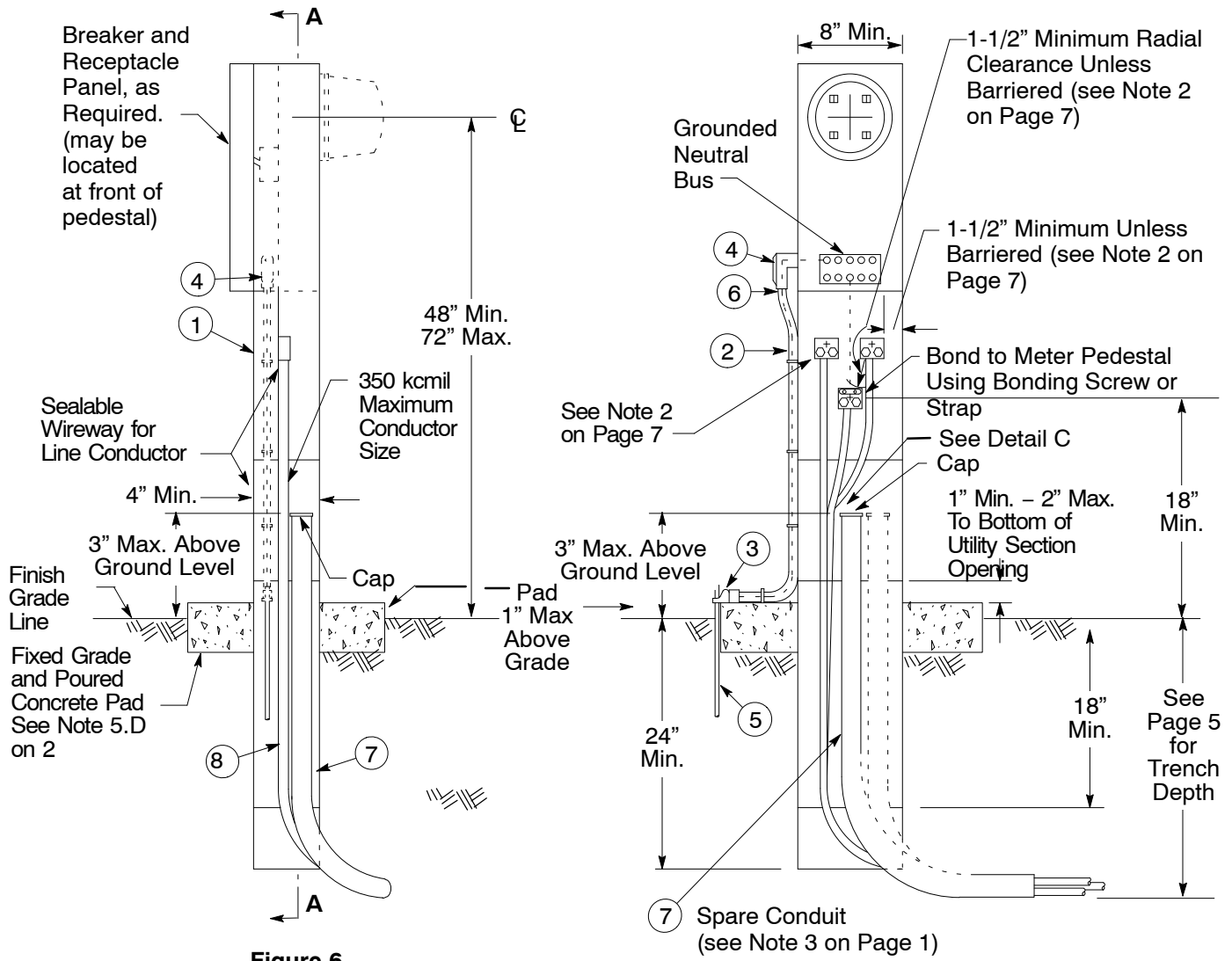
---

### ***Service and Meter Pedestal***

#### **Notes**

1. The meter pedestal shown on Page 8 may be used for a single service only.
2. Termination lugs for a pedestal shall be twin #6 to 350 kcmil range, aluminum bodied pressure type for connecting a single-service lateral and a single streetlight service when needed. Lug height, measured to the bottom of the terminating lug from grade line, shall be 18 inches minimum and 36 inches maximum. The space between terminating lugs, from lugs to sides of pedestal, from lugs to any grounded surface, or from lugs to panel above shall be 1-1/2 inch minimum. Rigid insulating barriers are required and shall project 1/4-inch minimum beyond any energized parts when this space is reduced. Terminating lugs may be positioned either in-line or staggered, and access shall be unobstructed when all service conductors are in place.
3. Meter height may be reduced to 36 inches if it is enclosed or guarded by a hinged protective hood (see Note 10B on Page 2).
4. The pedestal shown on Page 8 may also be used for an underground service to an individual mobile home not in a park.
5. The pedestal shown in Figure 6 on Page 8 is limited by its pull-section size to a maximum of 350 kcmil conductors.

**Service and Meter Pedestal (continued)**



**Figure 6**  
**Service and Meter Pedestal**

PG&E Service Conduit  
(see Note 3 on Page 1)

**Section A-A**

**Detail C**  
**Cable and Conduit Arrangement**

**Revision Notes**

Revision 06 has the following changes:

1. Updated Notes 5.B on Page 1 and 5.D on Page 2.
2. Updated Note 10.D on Page 2.
3. Updated Figure 5 on Page 5
4. Updated Table 1 on Page 6.
5. Removed Detail C and Table 2 on Page 7 about Compression Type Terminals.
6. Updated Figure 6.